

C Series 1 & 2 Canisters Models

CHARCOAL ADSORBER HOUSINGS

Charcoal Canister Housings for Glycol and Amine Systems

INTRODUCTION

Charcoal filtration is required to remove oils, well inhibitors, dissolved hydrocarbons and degradation compounds from triethylene glycol, amine, natural gas dehydrators and sweeteners.

The C series (formerly Nowata) activated carbon, canister type filter, is designed for low pressure charcoal treatment of these glycol and amine systems in order to minimize fouling and keep operating efficiency high. Canister type carbon cartridges are the most economical type of activated carbon adsorbers for flow rates up to 180 gph (3 gpm). The canister makes charcoal replacement much easier and disposal much cleaner than loose charcoal.

FEATURES

- 1 and 2 canister models available
- 150 psi working pressure rating
- Bolted closure for fast & easy canister replacement
- Buna O-ring seal
- Glycol / Amine flow rates to 180 gph
- Carbon steel construction
- ASME code construction available



STANDARD CONSTRUCTION

Connections

Inlet and outlet connections are available in smaller than standard sizes to fit customer requirements. 150# RF ANSI flanges are also available by special order. An internal pipe thread drain and a vent connections are standard. Flanged or external pipe thread, and non-standard sizes are available by special order. Special purpose connections such as relief valve fittings and pressure taps are available to meet a customer's specific requirements. Customization of many features is available including non-standard connection locations, mounting heights and dimensions.

Seal Material

The standard Buna o-ring seal will operate to 220 °F. Ethylene Propylene and Viton seal materials are available for special service.

ASME Code

The C series 1 and 2 canister charcoal filters are designed in accordance with the Pressure Vessel Code of the American Society of Mechanical Engineers. When required, each unit can be stamped with the "UM" or "U" ASME symbol, denoting fabrication and testing performed by specific procedures.

DIMENSIONAL INFORMATION

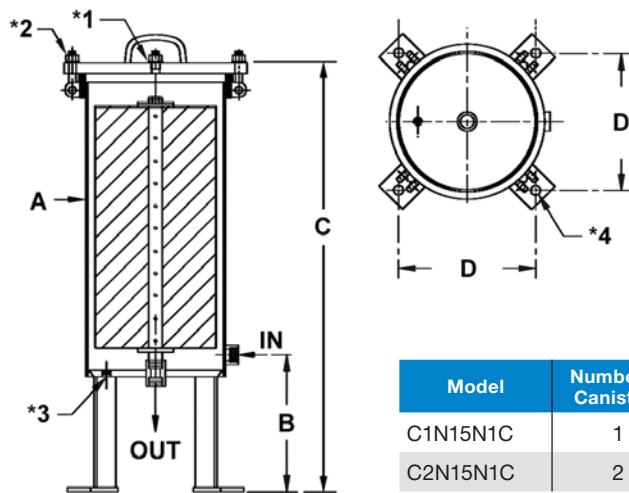

Model	Number of Canisters	A Outside Diameter	B	C	D	Weight (lbs)	Glycol + Amine Flow rates
C1N15N1C	1	12¾	12½	42	12½	255	90 gph (1.5 gpm)
C2N15N1C	2	12¾	12½	64¼	12½	325	180 gph (3 gpm)

Dimensions in inches except where noted. Due to our continuing program of product improvement, specifications are for reference only and subject to change without notice. Dimensions are approximate values and not intended for piping specifications.

NOTES: *1 = Vent 1/4" FNPT *3 = Drain 1/2" FNPT
 *2 = Cover bolts, 4 each, 5/8" *4 = Mounting holes (4 each) 7/8" on 17-11/16" B.C.

Internal canister support, screw and seal washer are plated carbon steel. The top closure uses four 5/8" diameter bolts (*2) attached to the vessel which swing away from the closure during canister removal. 1" internal pipe thread inlet and outlet connections are standard. Also provided as standard are an internal pipe thread vessel drain (*3) 1/2" FNPT and a vent (*1) 1/4" FNPT in the housing closure lid.