

C Series High Flow Models

CHARCOAL ADSORBER HOUSINGS

Charcoal Canister Housings for Glycol and Amine Systems

INTRODUCTION

Closed loop glycol and amine systems will pick up solids, oils, well inhibitors and dissolved hydrocarbons from the natural gas stream, fouling the fluids and causing a loss in operating efficiency. Sludge buildup, foaming and fluid discoloration are indications that fouling has occurred.

This can mean loss of glycol to the gas stream or total shutdown of the dehydration or sweetening process. A cartridge type fiber filter will remove the solid contaminants, but a charcoal bed is required for removal of the oils, dissolved hydrocarbons, well inhibitors and degradation compounds from the glycol or amine systems.

The C series (formerly Nowata) activated carbon canister type adsorber is designed to remove entrained hydrocarbons from glycol and amine streams which eliminates fouling and maintains operating efficiency.

Canister type carbon cartridges are the most economical type of activated carbon adsorbers for flow rates up to 20 gpm. Because the charcoal is contained inside the canister, charcoal replacement is easier and disposal much cleaner than loose charcoal.

FEATURES

- Standard sizes: 4, 6, 10 and 14 canister models (1 and 2 canister models also available)
- 4 canister model - 150 psi working pressure
- Larger models - 150 psi working pressure (Larger sizes and higher pressure models available)
- Bolted closure for fast, easy canister replacement
- Convenience of containerized carbon rather than bulk
- Buna o-ring standard, other seal materials available
- Glycol/Amine flow rates to 20 gpm
- Carbon steel construction standard
- Epoxy lined carbon steel offered
- Stainless steel construction also available



STANDARD CONSTRUCTION

The C series, high flow, charcoal adsorbers are designed for low pressure charcoal treatment of glycol and amine in natural gas dehydrators and sweeteners. These units feature welded carbon steel construction with plated internal canister supports and retainers. The top closure lid utilizes bolting which is permanently attached to the vessel wall and swings away from the top during canister removal and replacement.

The closure seal is a Buna o-ring. The standard inlet and outlet connections are 1" or 2" internal pipe thread, corresponding to the vessel size and number of canisters. All units are equipped with internal pipe thread vessel drain and vent.

See the Dimensional Information table for housing information which includes: the number of canisters that each model holds, the connection sizes, connection locations and flow ratings.

OPTIONAL CONSTRUCTION FEATURES

Materials of Construction

C series housings are constructed of all carbon steel with plated carbon steel internals. Post weld heat treatment (stress relieving) is available on special order for sour service.

Stainless steel construction is also available.

Seal Material

The standard Buna o-ring seal will operate to 220 °F. Viton and Ethylene Propylene seals are available for special service. For best hydrocarbon removal efficiency, the operating temperature should be held below 120 °F.

Connections

Inlet and outlet connections are available in sizes other than standard to fit customer requirements. Internal pipe thread drain and vent connections are provided as standard. ANSI flanges, external pipe thread, or non-standard sizes are available by special order.

Special purpose connections such as relief valve fittings and pressure taps are available to meet specific requirements. Non-standard connection location, unusual mounting heights or dimensions are also available.

Special Pressure Ratings

The standard four canister housing is rated for a working pressure of 150 psi. Standard pressure rating of the larger housings is also 150 psi. All C series housings are designed with a 1/32" corrosion allowance as standard. Also, special pressures and greater corrosion allowances are readily available.

Accessories

Several items are available to monitor or control filter operation. Differential pressure is not an indication that the carbon canister needs to be replaced. Therefore, a differential pressure gauge is not recommended for charcoal vessels. A pressure gauge, located in the vent connection, is an important safety device used to protect the operator from inadvertently opening the vessel closure under pressure. A vent valve should be installed to remove air trapped during canister replacement.

ASME Code Construction

The C series filters are designed in accordance with the Boiler and Pressure Vessel Code of the American Society of Mechanical Engineers. When required, each housing unit can be stamped with the U symbol, denoting fabrication and testing performed by specific procedures.

DIMENSIONAL INFORMATION

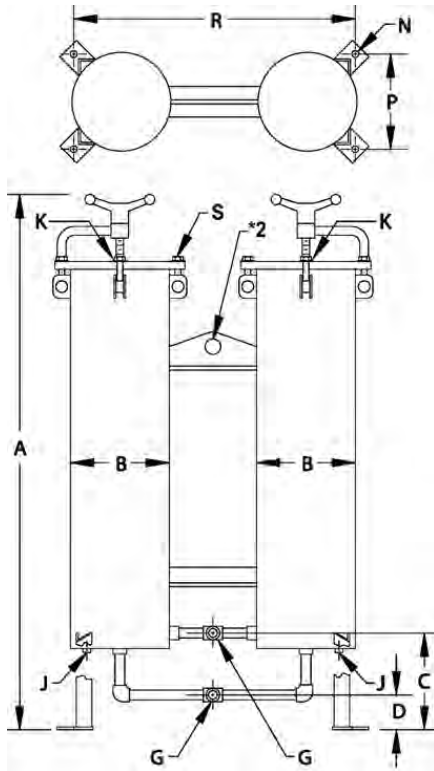

Typical Drawing for C4 Models (4 Canister Duplex)

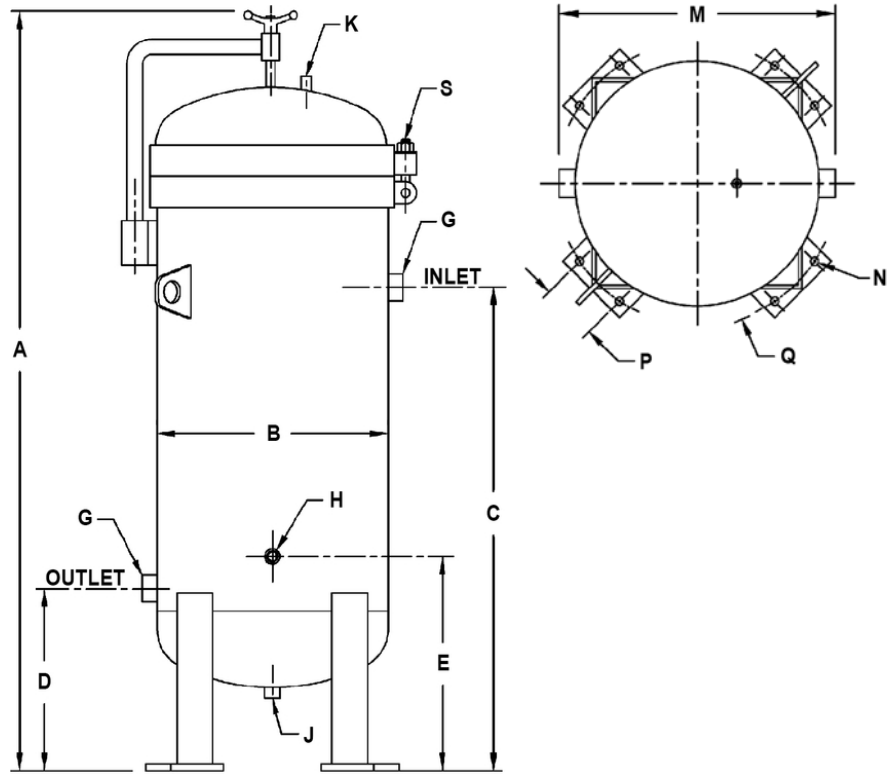

Typical Drawing for Models: C6, C10 & C14

| Model | Number of Canisters | Max. Pressure (psi-KGM/SQCK) | Max. Flow Rate (gpm) | Shipping Weight | | A | B | C | D | E | G | H | J | K | M | N | P | Q | R | S |
|-------|---------------------|------------------------------|----------------------|-----------------|-----|----|--------------------------------|--------------------------------|--------------------------------|--------------------------------|---|----|-----|-----|--------------------------------|------------|--------------------------------|----|--------------------------------|---------------|
| | | | | lbs | kg | | | | | | | | | | | | | | | |
| C4 | 4 | 150 - 10.5 | 6 | 740 | 336 | 66 | 12 ³ / ₄ | 12 ¹ / ₂ | 4 ¹ / ₂ | -- | 1 | -- | 1/2 | 1/4 | -- | (4 ea) 7/8 | 12 ¹ / ₂ | -- | 36 ¹ / ₂ | (8 ea) 3/4 NC |
| C6 | 6 | 150 - 7 | 9 | 1100 | 500 | 88 | 26 | 58 | 20 ¹ / ₂ | 24 ⁷ / ₈ | 2 | 1 | 1 | 1/2 | 29 ³ / ₈ | (8 ea) 7/8 | 6 | 30 | -- | (6 ea) 1 NC |
| C10 | 10 | 150 - 7 | 15 | 1550 | 700 | 93 | 32 | 60 | 22 ¹ / ₂ | 26 | 2 | 1 | 1 | 1/2 | 35 ³ / ₈ | (8 ea) 7/8 | 6 | 36 | -- | (6 ea) 1 NC |
| C14 | 14 | 150 - 7 | 21 | 1800 | 815 | 93 | 36 | 60 | 22 ¹ / ₂ | 25 ⁷ / ₈ | 2 | 1 | 1 | 1/2 | 39 ³ / ₈ | (8 ea) 7/8 | 6 | 40 | -- | (6 ea) 1 NC |

Dimensions in inches except where noted. Due to our continuing program of product improvement, specifications are for reference only and subject to change without notice. Dimensions are approximate values and not intended for piping specifications.

NOTES:

*2 = Cover bolts, 4 each, 5/8"

Max. Pressure = Maximum allowable non-shock pressure

Max. Flow Rate = Recommended maximum flow rate of glycol or amine. For charcoal to operate properly, the velocity of the fluid through the media should be relatively low. Flow ratings are based on dwell time in the carbon rather than velocity induced pressure drop across the canister. Oversizing the filter will provide more efficient removal of contaminate.

A = Overall height

B = Vessel diameter

C = Height to inlet centerline

D = Height to outlet centerline

E = Height to dirty chamber drain

G = Inlet and outlet connection size, Internal pipe thread standard

H = Internal pipe thread dirty chamber drain size

J = Internal pipe thread drain size (Note: Two drains on the Model C4)

K = Internal pipe thread vent size (Note: Two vents on the Model C4)

M = Inlet and outlet face to face

N = Mounting hole quantity and diameter

P = Mounting hole spacing

Q = Mounting hole circle diameter

R = C4 mounting hole spacing

S = Closure bolt quantity and size

REPLACEMENT CHARCOAL CANISTERS

The 1122-C-N replacement charcoal canisters are 11" O.D. x 22" long. The granulated charcoal is held in place by a fabric outer sleeve just inside the perforated steel shell. The charcoal will not migrate downstream due to a microscreen inner seal and perforated rigid metal core. Each cartridge has gasket end seals and lifting handle for ease of replacement. The 1122-C-N canister contains approximately 31 pounds of granulated charcoal.

Charcoal adsorbers operate most efficiently when the operating temperature is less than 120 °F. Operation at a temperature greater than 220 °F is not recommended. The Jonell Systems Model 1122-C-N replacement canisters are shipped in individual cardboard boxes which can be used for handling and disposal of spent canisters. The Jonell Systems 1122-C-N canister is a replacement for competitive activated charcoal elements that are 11" O.D. x 22" long.

TYPICAL MODEL NUMBER

