

---

# GAS FILTER SEPARATORS

---

Making the world safer, healthier and more productive.



## UNDERSTANDING THE ROLE OF GAS FILTER SEPARATORS

A workhorse of the gas industry, the Gas Filter Separator is one of the most widely used filtration devices on the market. Introduced more than 70 years ago, it has become the equipment of choice to purify natural gas and protect your capital investment.

The function of a Gas Filter Separator is to remove fine-to-medium sized solid contaminants and entrained liquid from a natural gas stream. Typical contaminants include:

- High and medium surface tension liquids such as water and hydrocarbons.
- Non shear sensitive solids such as sand, corrosion compounds and abrasives.
- Pipeline and plant chemicals.

The versatility of the gas filter separator is characterized through its high dirt holding capacity and excellent liquid handling capability.

### Major Applications of Gas Filter Separators

- Gas storage facilities
- Glycol dehydrators
- Metering stations
- Natural gas compressors

## HOW IT WORKS

---

Often confused with a Reverse Flow Coalescer or a Separator, its design consists of three stages of filtration and separation: the knockout stage, the element stage and the separator stage. The element and separation stages are housed in separate compartments.

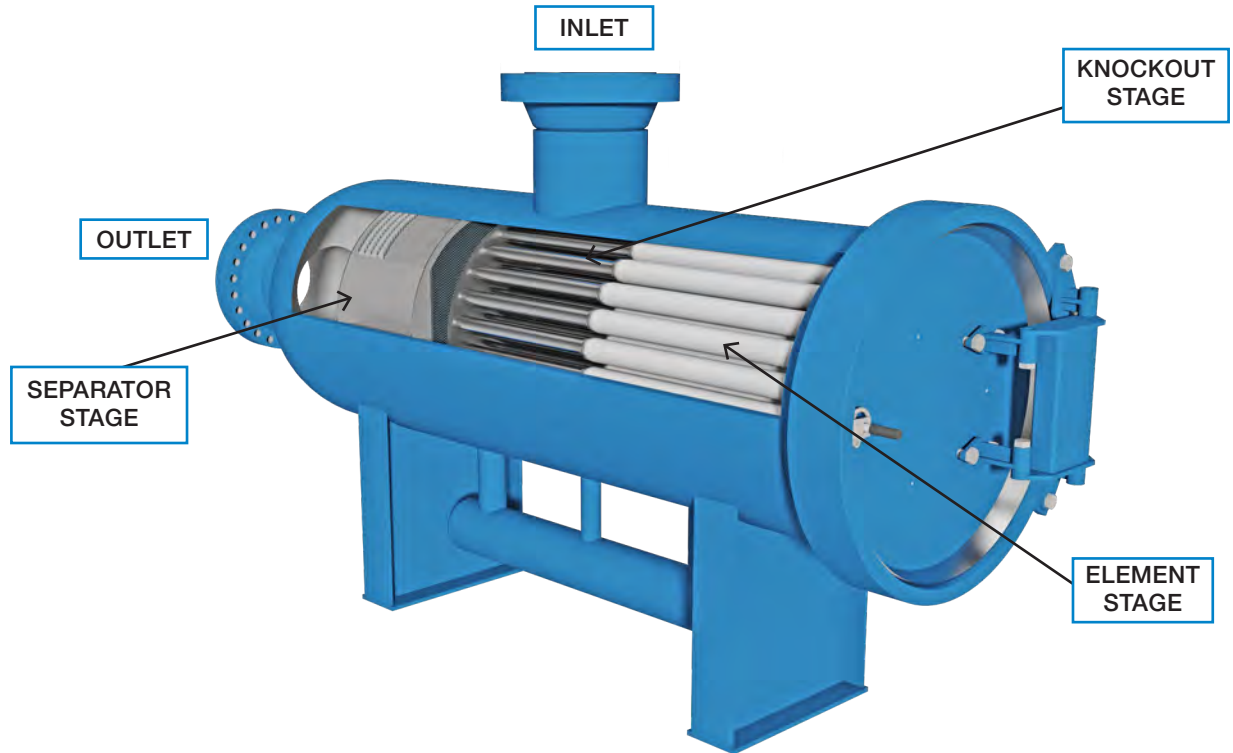

### Knockout Stage

As natural gas enters the Filter Separator, it impinges on element support posts, also known as risers. Correct length of the risers is important to prevent direct gas impingement on the elements. Gas impingement on the risers is used to disengage any contaminant from the gas stream via impaction, deflection and gravity. In order to maximize deflection and make the most of gravity separation, Jonell Systems Filter Separators utilize a special optimized riser layout.

### Element Stage

In the standard offering the element stage of the Filter Separator is fitted with Jonell Systems patent pending TRI-SHIELD depth cartridges for maximum dirt loading. The direction of flow is outside-to-inside for maximum solids removal. The cartridges also serve the function of coalescing liquid droplets. At this stage the precoalesced droplets are ready to be removed from the gas stream in the final separator stage. Typically cartridge change-out is performed based on a pre-determined interval or differential pressure.

### Separation Stage

Depending on the nature of contaminant, the separation stage can be equipped with one of three available separation devices:

- A wire mesh mist eliminator
- A vane pack or mesh-vane assembly
- A centrifugal device

---

### Wire Mesh Mist Eliminator

For maximum performance, two Jonell Systems knitted mesh pads with varying density and thickness are fitted into the second compartment. Typical materials include various grades of stainless steel. Nonstandard materials are also available for special applications.

Two benefits of using wire mesh is the low pressure drop and improved cost-effectiveness. Wire mesh is not recommended for sticky fouling contaminant or for highly corrosive service.

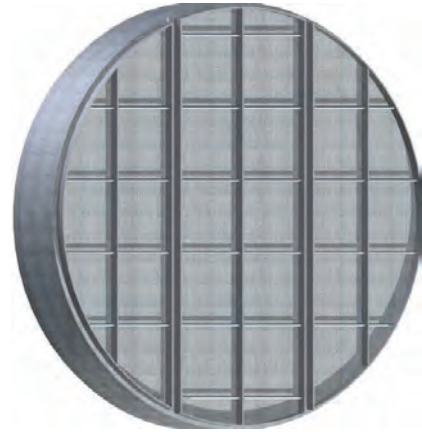

---

### Vane Mist Eliminator

vane packs are custom engineered to meet process requirements. A multitude of specially shaped plates creates a tortuous path for the gas to pass through. Typical materials include various grades of stainless steel encased in a carbon steel enclosure.

Some of the benefits of using a vane pack in the final stage of a Filter Separator are a lower pressure drop, compact design and increased longevity.



---

### Centrifugal Mist Eliminator

A cyclonic device called the JHAC cyclonic mist eliminator is recommended for severe, fouling service with high liquid loads. This type of device induces a spinning motion on the entering gas resulting in the ejection of contaminant via centrifugal force. Our design ensures a continuous recirculation of gas, which prevents plugging and promotes self-cleaning. These cyclonic tubes are typically used in multiples determined by operating conditions. Carbon steel is the standard material with other materials also available. It is the most versatile separation device on the market and can be fitted into a Filter Separator for almost any application.



---

## HORIZONTAL FILTER SEPARATOR

A Horizontal Filter Separator is fitted with two separate liquid collection chambers separated with a baffle plate. Each liquid chamber is sized proportionally to the upper barrel as well as expected liquid loading. Two stages of controls (manual or automated) are required for liquid monitoring and drainage.

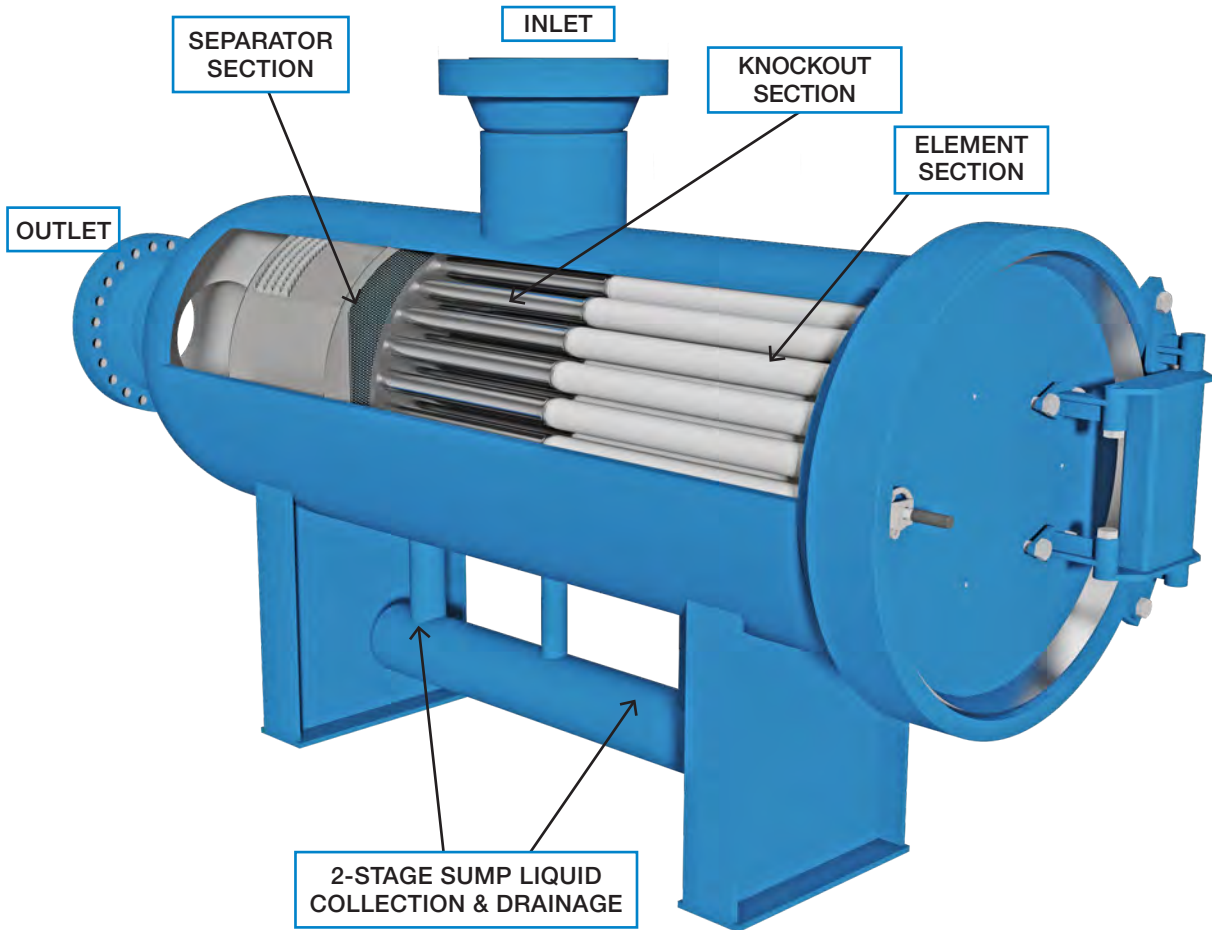

A correctly designed Filter Separator should achieve a maximum turn down of 10:1 and maintain a minimum efficiency of 99.98% of 1 micron and larger and up to 0.3 micron on solids throughout the entire range of operating conditions. Drainage and control of liquids is essential to achieving this efficiency.

## Vertical Filter Separator

A Vertical Filter Separator is designed with a top-to-bottom flow configuration and is most commonly designed with a vane pack or mesh-vane separator stage. This design also necessitates two liquid collection chambers. Any liquid drained from the first stage, or upper chamber, is collected and drained off to a common drain header. The second stage, or lower chamber, retains liquids that have been removed from the gas stream by the vane pack and is drained to a common header.

## Common Attributes

A number of additional essential design aspects include element flow capacity, nozzle velocities, bulk and annular velocities, element spacing, nozzle positioning, gas contact area in the separator stage, pressure drop and flux rates. In every Jonell Systems Vertical Filter Separator, all requirements of process design have been considered to ensure optimal performance.

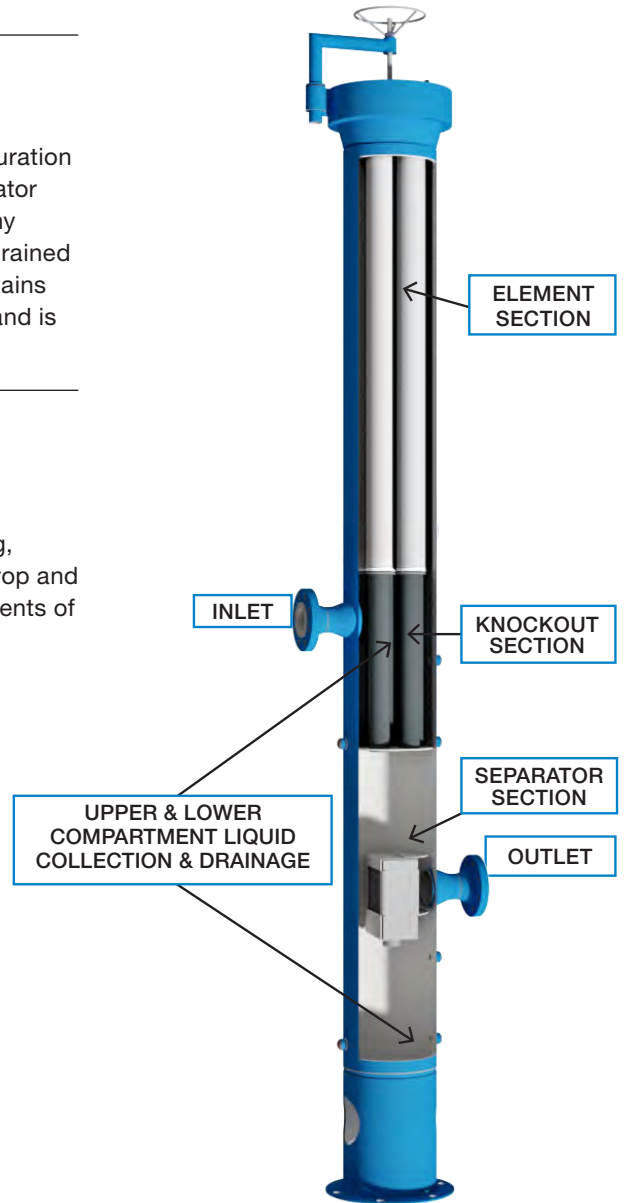

## Typical Model Number

<b>G</b>	<b>W</b>	<b>A</b>	<b>C</b>	<b>1</b>	<b>C</b>	<b>27</b>	<b>F</b>	<b>2</b>	<b>C</b>	<b>A</b>	<b>N</b>	
<b>Jonell Systems Series</b> Gas Housings	<b>Closure Style</b> A Flat swing bolt B Domed swing bolt D RFWN flange top F RFSO flange top S Screw top Y Yoke or internal door	<b>Qty of Elements</b> Number of Elements	<b>Pressure Rating</b> 27 275 psi 74 740 psi 144 1440 psi	<b>Inlet/Outlet Size (inch)</b> 2 12 3 14 4 16 6 18 8 20 10 24	<b>Internal Cart. Size</b> 3½" OD x length A 12" D 36" C 24" E 72" 4½" OD x length F 12" J 36" H 24" K 72" 5½" OD x length P 36" R 72"	<b>Options</b> Assigned by Jonell Systems to indicate specials	<b>Vessel Orientation</b> W Vertical E Horizontal	<b>Housing Material</b> C Carbon Steel U 316SS Wetted A 304SS Wetted	<b>ASME Code</b> C ASME U stamp N No U stamp	<b>Inlet/Outlet Style</b> F RFSO L RFLWN N FNPT W RFWN	<b>Internal Material</b> A 304 SS C Carbon Steel U 316 SS	<b>O-Ring Material</b> N Buna-N V Viton E EPDM S Teflon encapsulated silicon T Teflon encapsulated Viton F Flat Gasket

## Element Selection

### Standard Element Construction:

patent pending TRI-SHIELD™ JFS Series media cartridges with blend of Tri-Lobal and cylindrical fibers in combination with the engineered gradient depth all in the same media matrix provides pre-coalescing and 20% higher dirt loading compared to conventional depth cartridges.

Also available in pleated and depth glass where application specifics would be better solved with this solution.

filter separator elements are available in various standard and custom sizes to fit virtually every application. They are engineered and manufactured in standard fiberglass, micro-glass and polymeric media to ensure compatibility with process.

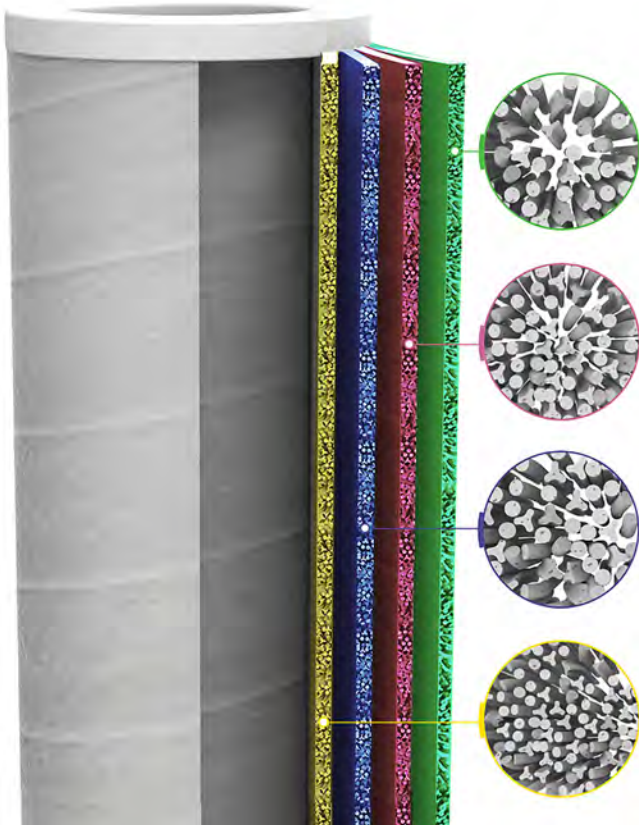

### JFS SERIES

<b>Material of Construction</b>	Depth Style Polyester Depth Style Polypropylene
<b>Maximum Temperature</b>	240°F (Polyester) 180°F (Polypropylene)
<b>Minimum Temperature</b>	-60°F
<b>Change Out Differential</b>	12- 15 PSID
<b>Collapse Pressure</b>	>75 PSID
<b>Available Micron Rating</b>	0.3, 0.5, 1, 5, 10
<b>Standard Sizes</b>	312, 324, 336, 348, 372 512, 524, 536, 548, 572

### JFG SERIES

<b>Material of Construction</b>	Fiberglass
<b>Maximum Temperature</b>	275°F
<b>Minimum Temperature</b>	-60°F
<b>Change Out Differential</b>	12-15 PSID
<b>Collapse Pressure</b>	>75 PSID
<b>Available Micron Rating</b>	1, 5,10
<b>Standard Sizes</b>	312, 324, 336, 372, 536, 572

### JMG SERIES

<b>Material of Construction</b>	Micro-Glass
<b>Maximum Temperature</b>	275°F
<b>Minimum Temperature</b>	-60°F
<b>Change Out Differential</b>	12-15 PSID
<b>Collapse Pressure</b>	>75 PSID
<b>Available Micron Rating</b>	0.3, 0.5, 1, 5, 10
<b>Standard Sizes</b>	312, 324, 336, 372, 536, 572