

WD Series - Top Entry DuPlex

BAG FILTER HOUSINGS

Standard Housings: ASME Code
Accommodate #2 Size Bags

INTRODUCTION

The Top Entry DuPlex (formerly Nowata) bag filter housings include isolation valves to allow one vessel's media to be changed-out while the other vessel is left on-line to continue filtering. These high quality, industrial and commercial service bag filters are designed to withstand years of field and plant operation.

The standard design configuration of these units assures that they can be easily incorporated into your system. In applications requiring high volume filtration at moderate efficiency, the Top Entry DuPlex bag filter housings will provide rugged and dependable service at a price that makes them the sure choice. The design of these housings allows the use of standard and high efficiency bags plus a wide variety of O-ring materials with no change in design. This means that whether its glycol, hydrocarbons, coolant, inks or water, the Top Entry DuPlex bag filter housings will fit the need.

FEATURES

- Standard vessels are ASME code (Non-code vessels are also available)
- Standard - All wetted parts 316 stainless steel 150 psi working pressure, temp. 250 °F max. (Higher temperatures available upon request)
- Adjustable leg assembly and manifold supports allow elevation to be field adjusted
- For use with standard #2 size bags (7" x 30")
- Designed for use with heavy duty, high efficiency bags and standard thickness conventional bags
- Stainless steel perforated basket included
- Available in valved or non-valved configurations
- Isolation valves allow one vessel's media to be changed while the other is left on-stream to continue filtering
- Designed to withstand years of field and plant operation
- Housing design allows the use of standard and high efficiency bags plus a wide variety of o-ring material



STANDARD CONSTRUCTION

The standard material used for construction of the Top Entry DuPlex bag housing is 316 stainless steel for all wetted parts. The housing lid assembly is an investment casting of the same material. The leg assembly is plated carbon steel and painted. The standard drain port for each vessel is 3/4" FNPT, mounted in the bottom elliptical head. There are two 1/4" FNPT vent/gauge ports located at the top of the lid assembly, as well as on the inlet and outlet manifold.

Both front and rear o-ring grooves are located on the body of the unit. This ensures that the o-rings maintain their placement during bag change-out. Viton o-rings are standard in both front and rear seals. The standard material used for construction of the perforated bas- kets is 316 stainless steel and can be customized to meet customer requirements. Standard valves are wafer style butterfly with EPDM seals and 316 stainless steel disc and stem.

DIMENSIONAL INFORMATION

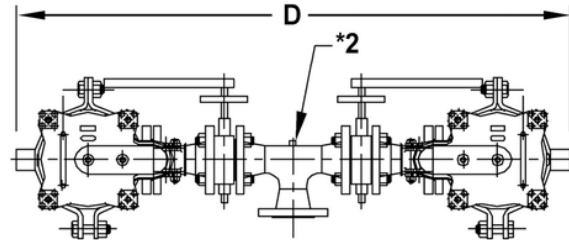
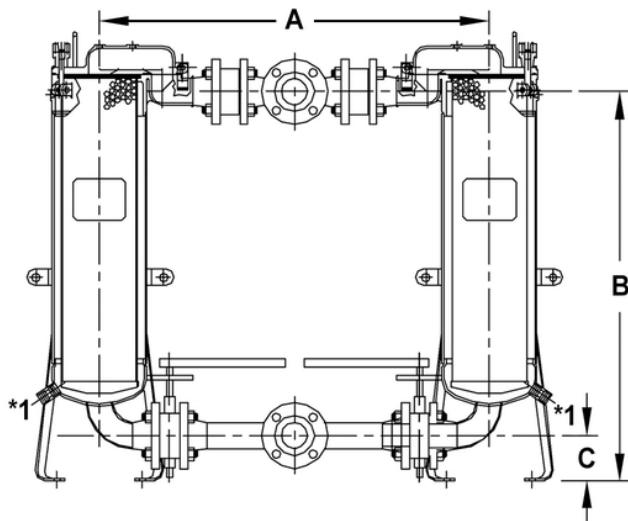

A	B ³	C ⁴	D
35½	35¾	4⅛	48¼

NOTES: *1 = Outside diameter, 8.5 inches *2 = Closure vents (2 each) 1/4 inch *3 & *4 = Minimum height (due adjustable legs)

Dimensions in inches except where noted. Due to our continuing program of product improvement, specifications are for reference only and subject to change without notice. Dimensions are approximate values and not intended for piping specifications.

Many features of the Top Entry DuPlex bag filter housings can be customized to meet customer requirements

TYPICAL MODEL NUMBER

WD	T	U	2	U	2	1	W	15	V
Jonell Systems Series	Inlet Location	Material of Construction	Number of Housings	ASME Code	Manifold Inlet/Outlet Size	Valves	Inlet/Outlet Header Style	Pressure Rating	O-Ring Material
WD = Top Entry DuPlex Bag Housing	T = Top Entry	U = 316 SS wetted	2	U = ASME Code N = Non-code	2 = 2" 3 = 3" 4 = 4"	1 = With valves 0 = No valves	W = RFWN	15 = 150 psi	N = Buna V = Viton E = EPDM More options available