

SUCTION FILTER

Series AS 632 DN 50 - 90

Sheet No.
1909 G

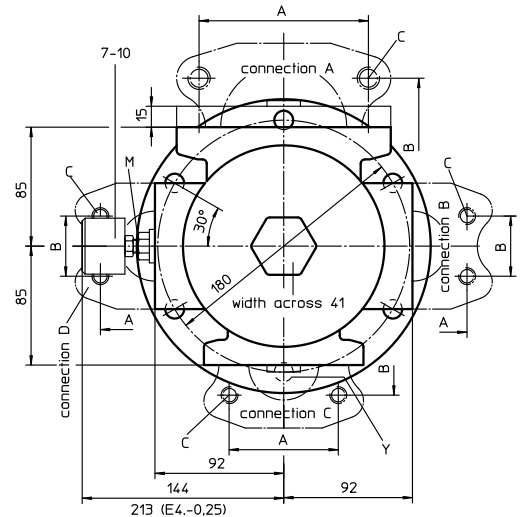
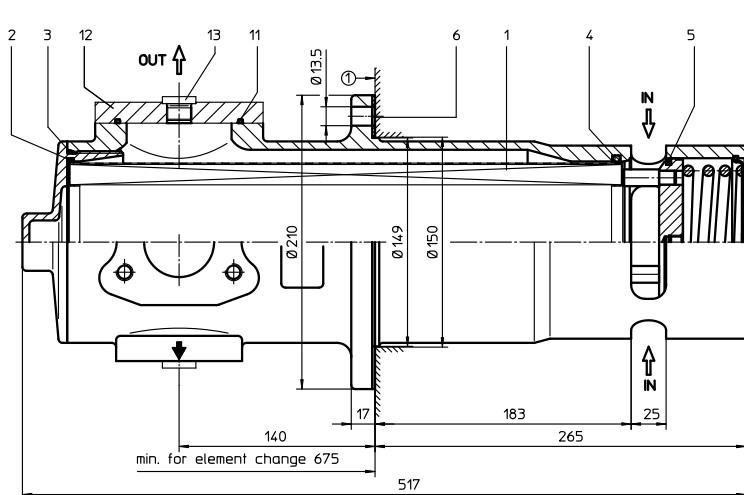

1. Type index:

1.1. Complete filter: (ordering example)

AS. 632. 40G. -. B. P. -. FS. 11. -. O1

1	2	3	4	5	6	7	8	9	10	11
---	---	---	---	---	---	---	---	---	----	----

- 1 **series:**
AS = suction filter
- 2 **nominal size:** 632
- 3 **filter-material and filter-fineness:**
80 G= 80 µm, 40 G= 40 µm stainless steel wire mesh, other materials on request
- 4 **resistance of pressure difference for filter element:**
- = not specified
- 5 **filter element design:**
B = both sides open
- 6 **sealing material:**
P = Nitrile (NBR); V = Viton (FPM)
- 7 **filter element specification:**
- = standard; VA = stainless steel
- 8 **connection:**
FS = SAE-flange connection 3000 PSI
- 9 **no. of version:**

version	1	5	6	10	11	12	14	21
connection A type size	XY	XY	XY	FS A1	FS A1	FS A1	-	FS A
connection B type size	Y	M	M	FS 8	FS 9	-	FS 8	Y
connection C type size	FS 8	FS 9	FS 9	Y	Y	Y	FS 8	Y
connection D type size	FS 8	FS 9	-	Y	M	M	FS 8	FS 8

type: FS = SAE-flange 3000 PSI
M = adapter M18 x 1,5 - R 1/8
Y = drain M18 x 1,5
X = adapter SAE 3" - M18 x 1,5
- = no connection

size: 8 = 2"
9 = 2 1/2"
A = 3"
A1 = 3 1/2"

10 filter housing specification:

- = standard

11 clogging indicator:

- = without
O1 = visual, see sheet-no. 1616
E4.-0,25 = pressure switch, see sheet-no. 1616

1.2. Filter element: (ordering example)

01AS. 631. 40G -. B -. -

1	2	3	4	5	6	7
---	---	---	---	---	---	---

- 1 **series:**
01AS. = suction filter element according to company standard
- 2 **nominal size:** 631
- 3 - 5, 7 see type index-complete filter
- 6 **sealing material:**
- = without

2. Dimensions:

connection size	2"	2 1/2"	3"	3 1/2"
dimension A	78	89	106,4	121
dimension B	43	51	62	70
thread C	M12, 18 deep	M12, 18 deep	M16, 22 deep	M16, 22 deep

3. Accessories:

- counter flange, see sheet-no. 1652

mounting area



surface quality



flatness tolerance

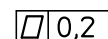

weight: approx. 12 kg

EDV 08/12

Changes of measures and design are subject to alteration!

4. Spare parts:

item	qty.	designation	dimension	article-no.	
1	1	filter element	01AS.631		
2	1	O-ring	115 x 3	303963 (NBR)	307762 (FPM)
3	1	O-ring	125 x 3	306025 (NBR)	307358 (FPM)
4	1	O-ring	115 x 5	306640 (NBR)	310287 (FPM)
5	1	O-ring	104,37 x 3,53	304339 (NBR)	304390 (FPM)
6	1	gasket	2 thick	305160	
7	1	adapter M18 x 1,5 - R 1/8	30505-4	317114	
8	2	gasket	A18 x 24x1,5	305136	
9	1	clogging indicator, visual	O1	301722	
10	1	clogging indicator, electrical	E4.-0,25	301725	
11	1	O-ring	85,32 x 3,53	305590 (NBR)	306308 (FPM)
12	1	adapter SAE 3" - M18 x 1,5	30294-3	317048	
13	1	screw plug	M18 x 1,5	305193	

5. Description:

The filter element consists of a star-shaped pleated filter material which is supported on the inside by a perforated core tube and is bonded to the end caps.

Internormen Product Line filter elements are known as elements with a high intrinsic stability and an excellent filtration capability, a high dirt-retaining capacity and a long service life.

The AS-filters are horizontally or vertically mounted to the reservoir and connected directly to the suction-line.

Due to its practical design the suction filter is easy to service. When releasing the filter lid a plate valve closes the suction-inlet of the filter and prevents the return flow of dirt oil to the reservoir, respectively when mounted horizontally the flow out of the reservoir is prevented.

After the servicing respectively after changing the element the filter is again ready for operation.

According to the operating condition the filter could be equipped with different accessories (clogging indicators, counter flange etc.).

6. Technical data:

temperature range:	-10°C to + 80°C (for a short time + 100°C)
connection system:	SAE-flange connection 3000 PSI
installation position:	optional
housing material:	G-AISI10Mg wa DIN 1725 (3.2381.61)
sealing material:	Nitrile (NBR) or Viton (FPM), other materials on request
usable for following fluids:	petroleum-based fluids, lubrication fluids; HW-emulsions and synthetic hydraulic fluids on request
volume tank:	6,3 l

Classified under the Pressure Equipment Directive 97/23/EC for mineral oil (fluid group 2), Article 3, Para. 3.

Classified under ATEX Directive 94/9/EC according to specific application (see questionnaire sheet-no. 34279-4).

7. Symbols:

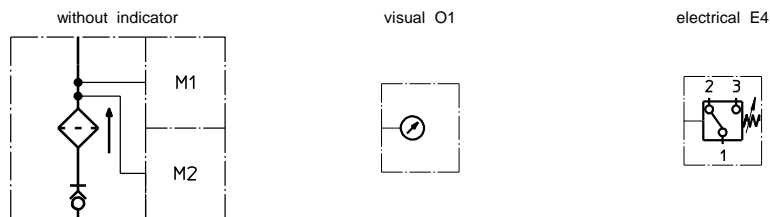

8. Pressure drop flow curves:

Precise flow rates see 'Interactive Product Specifier', respectively Δp -curves; depending on filter fineness and viscosity.

9. Test methods:

Filter elements are tested according to the following ISO standards:

ISO 2941	Verification of collapse/burst resistance
ISO 2942	Verification of fabrication integrity
ISO 2943	Verification of material compatibility with fluids
ISO 3723	Method for end load test
ISO 3724	Verification of flow fatigue characteristics
ISO 3968	Evaluation of pressure drop versus flow characteristics
ISO 16889	Multi-pass method for evaluating filtration performance