

Series EH 60-150 DN15-25 PN420

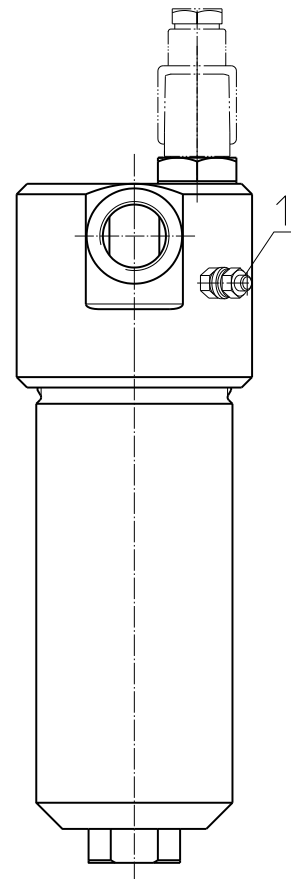

1) Connection for the potential equalization, only for application in the explosive area.

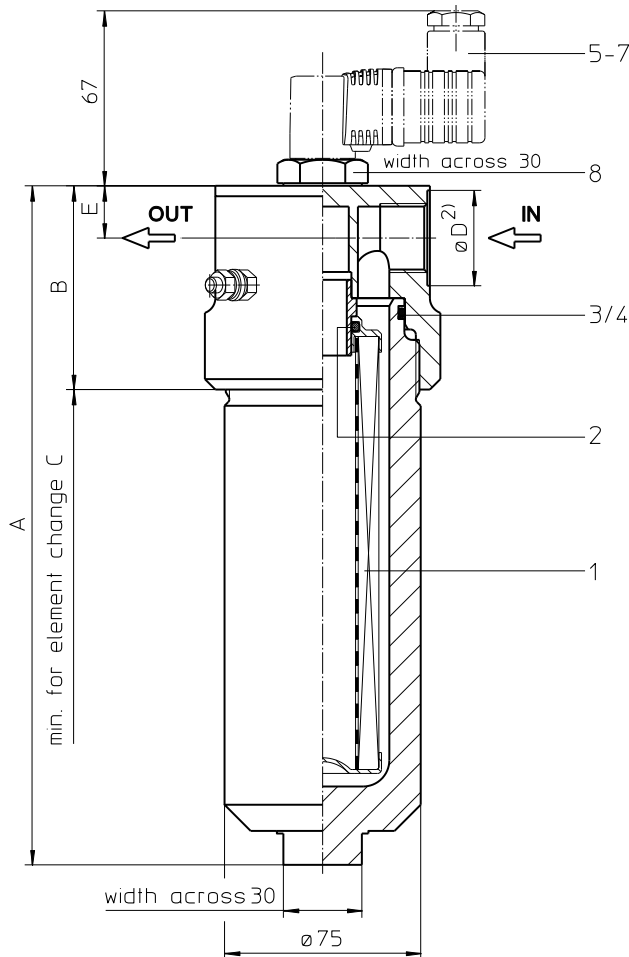
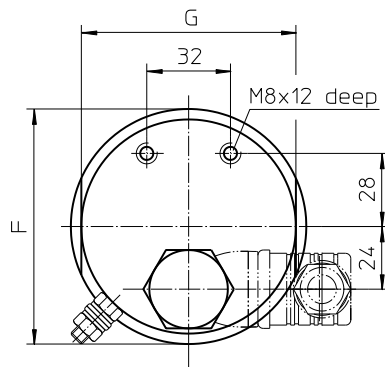

Dimensions:

type	EH 60	EH 90	EH 150
connection	1/2"	3/4"	1"
A	195	260	370
B	78	78	84
C	215	280	390
D ²⁾	30	36,5	40
E	20	20	23
F	90	90	95
G	82	82	84
weight kg	6	7	9
volume tank	0,3 l	0,4 l	0,6 l

Connection assignments as shown in the table are standard. To exchange connections see item 9 in the type index.

A. dimension only with execution according to ISO 228

Dimensions: mm

Designs and performance values are subject to change.

EDV 08/19

For more information:

WEB: FLTR.com.au PHONE: (+61) 1300 62 4020 EMAIL: info@FLTR.com.au SKYPE: Purple.Engineering

Pressure Filter

Series EH 60-150

DN15-25 PN420

Description:

Stainless steel-pressure filter series EH 60-150 have a working pressure up to 420 bar. Pressure peaks can be absorbed with a sufficient safety margin. The EH-filter is in-line mounted.

The filter element consists of star-shaped, pleated filter material, which is supported on the inside by a perforated core tube and is bonded to the end caps with a high-quality adhesive. The flow direction is from outside to inside. Filter elements are available down to 5 $\mu\text{m}_{(c)}$.

Eaton filter elements are known for high intrinsic stability and an excellent filtration capability, a high dirt-retaining capacity and a long service life.

Eaton filter elements are available up to a pressure resistance of Δp 160 bar and a rupture strength of Δp 250 bar.

Eaton filter are suitable for all petroleum based fluids, HW-emulsions, most synthetic hydraulic fluids and lubrication oils.

The internal valve is integrated into the filter head. After reaching the bypass pressure setting, the bypass valve will send unfiltered partial flow around the filter.

The reversing valve provides another level of protection for the filter element. The reverse flow will not be filtered.

1. Type index:

1.1. Complete filter: (ordering example)

EH.	90.	10VG.	HR.	E.	P.	VA.	G.	4.	VA.	-.	-.	AE
1	2	3	4	5	6	7	8	9	10	11	12	13

- 1 | **series:**
EH = stainless steel-pressure filter
- 2 | **nominal size:** 60, 90, 150
- 3 | **filter-material:**
80G, 40G, 25G stainless steel wire mesh
25VG, 16VG, 10VG, 6VG, 3VG microglass
- 4 | **filter element collapse rating:**
30 = Δp 30 bar
HR = Δp 160 bar (rupture strength Δp 250 bar)
- 5 | **filter element design:**
E = single-end open
- 6 | **sealing material:**
P = Nitrile (NBR)
V = Viton (FPM)
- 7 | **filter element specification:**
- = standard
VA = stainless steel
- 8 | **process connection:**
G = thread connection according to ISO 228
NPT = thread connection according to ANSI B1.20.1
- 9 | **process connection size:**
3 = 1/2"
4 = 3/4"
5 = 1"
- 10 | **filter housing specification:**
VA = stainless steel
- 11 | **specification pressure vessel:**
- = standard (PED 2014/68/EU)
IS20 = ASME VIII Div.1 with ASME equivalent material, see sheet-no. 55217 (max. operating pressure 280 bar)
- 12 | **internal valve:**
- = without
S1 = with by-pass valve Δp 3,5 bar
S2 = with by-pass valve Δp 7,0 bar
R = reversing valve, $Q \leq 70,06$ l/min
- 13 | **clogging indicator or clogging sensor:**
- = without
AOR = visual, see sheet-no. 1606
AOC = visual, see sheet-no. 1606
AE = visual-electric, see sheet-no. 1615
VS5 = electronic, see sheet-no. 1619

To add an indicator/sensor to your filter, use the corresponding indicator data sheet to find the indicator details and add them to the filter assembly model code.

1.2. Filter element: (ordering example)

01E.	90.	10VG.	HR.	E.	P.	VA
1	2	3	4	5	6	7

- 1 | **series:**
01E. = filter element according to company standard
- 2 | **nominal size:** 60, 90, 150
- 3 | - | 7 | see type index-complete filter

For more information:

WEB: FLTR.com.au PHONE: (+61) 1300 62 4020 EMAIL: info@FLTR.com.au SKYPE: Purple.Engineering



Technical data:

operating temperature:	-10°C to +100°C
operating medium	mineral oil, other media on request
max. operating pressure:	420 bar
test pressure:	600 bar
max. operating pressure at IS20:	280 bar
test pressure at IS20:	364 bar
process connection:	thread connection
housing material:	EN10088-1.4571 (320 S 18, 320 S 31 according to B.S.)
sealing material:	Nitrile (NBR) or Viton (FPM), other materials on request
installation position:	vertical

Classified under the Pressure Equipment Directive 2014/68/EU for mineral oil (fluid group 2), Article 4, Para. 3.
 Classified under ATEX Directive 2014/34/EU according to specific application (see questionnaire sheet-no. 34279-4).

Pressure drop flow curves:

Filter calculation/sizing

The pressure drop of the assembly at a given flow rate Q is the sum of the housing Δp and the element Δp and is calculated as follows:

$$\Delta p_{assembly} = \Delta p_{housing} + \Delta p_{element}$$

$$\Delta p_{housing} = (\text{see } \Delta p = f(Q) \text{ - characteristics})$$

$$\Delta p_{Element} (mbar) = Q \left(\frac{l}{min} \right) \times \frac{MSK}{10} \times v \left(\frac{mm^2}{s} \right) \times \frac{p}{0,876} \left(\frac{kg}{dm^3} \right)$$

For ease of calculation our Filter Selection tool is available online at www.eatonpowersource.com/calculators/filtration/

Material gradient coefficients (MSK) for filter elements

The material gradient coefficients in mbar/(l/min) apply to mineral oil (HLP) with a density of 0,876 kg/dm³ and a kinematic viscosity of 30 mm²/s (139 SUS). The pressure drop changes proportionally to the change in kinematic viscosity and density.

EH	VG					G		
	3VG	6VG	10VG	16VG	25VG	25G	40G	80G
60	5,438	3,775	2,417	2,104	1,438	0,2205	0,1635	0,1526
90	3,271	2,271	1,454	1,266	0,865	0,1333	0,0988	0,0922
150	1,952	1,355	0,867	0,755	0,516	0,0796	0,0590	0,0551

$\Delta p = f(Q)$ – characteristics according to ISO 3968

The pressure drop characteristics apply to mineral oil (HLP) with a density of 0,876 kg/dm³. The pressure drop changes proportionally to the density.

--- 30mm²/s — 100 mm²/s

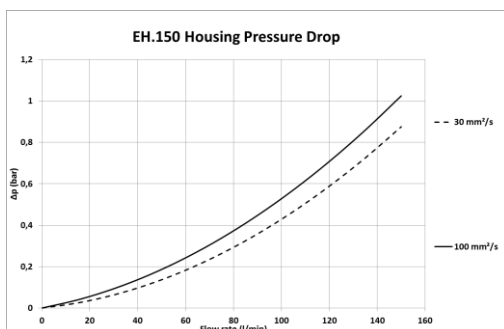
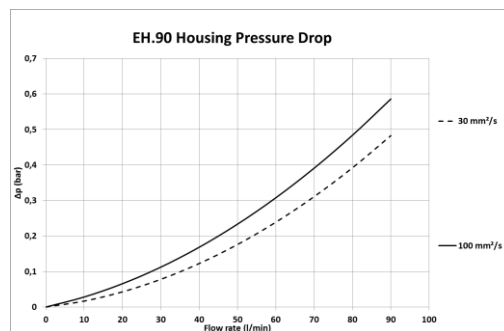
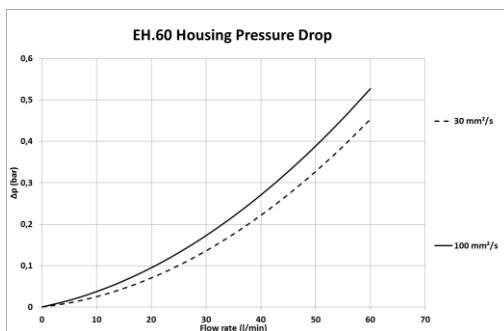

For more information:

WEB: FLTR.com.au PHONE: (+61) 1300 62 4020 EMAIL: info@FLTR.com.au SKYPE: Purple.Engineering



Symbols:

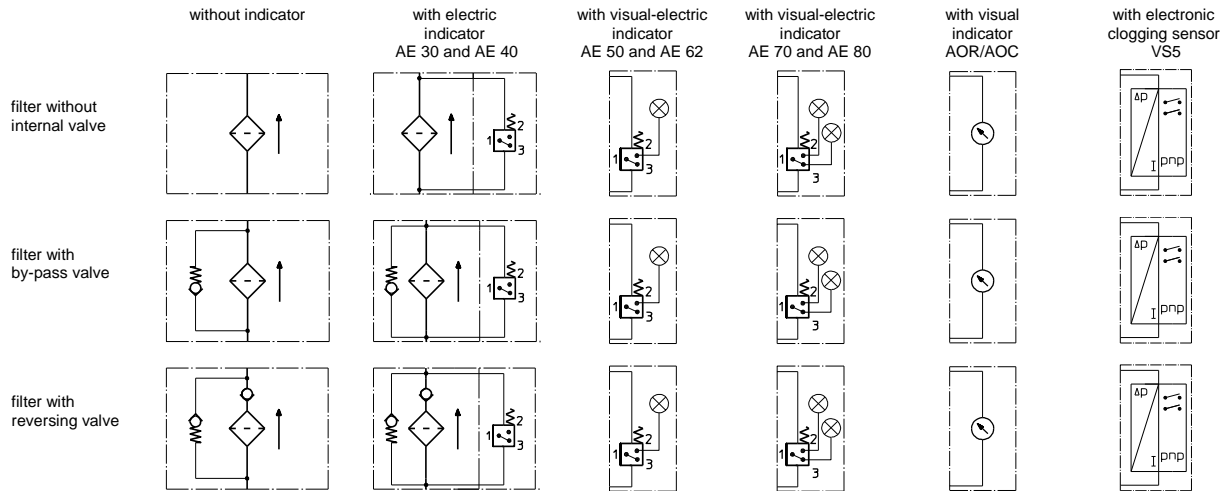

Spare parts:

item	qty.	designation	dimension			article-no.	
			EH 60	EH 90	EH 150		
1	1	filter element	01E.60...	01E.90...	01E.150...		
2	1	O-ring	22 x 3,5			304341 (NBR)	304392 (FPM)
3	1	O-ring	56 x 3			305072 (NBR)	305322 (FPM)
4	1	support ring	63 x 2,6 x 1			312309	
5	1	clogging indicator visual	AOR or AOC			see sheet-no. 1606	
6	1	clogging indicator visual-electric	AE			see sheet-no. 1615	
7	1	clogging sensor electronic	VS5			see sheet-no. 1619	
8	1	screw plug	20913-4			314442	

item 8 execution only without clogging indicator or clogging sensor

Test methods:

Filter elements are tested according to the following ISO standards:

ISO 2941	Verification of collapse/burst resistance
ISO 2942	Verification of fabrication integrity
ISO 2943	Verification of material compatibility with fluids
ISO 3723	Method for end load test
ISO 3724	Verification of flow fatigue characteristics
ISO 3968	Evaluation of pressure drop versus flow characteristics
ISO 16889	Multi-pass method for evaluating filtration performance

For more information:

WEB: FLTR.com.au PHONE: (+61) 1300 62 4020 EMAIL: info@FLTR.com.au SKYPE: Purple.Engineering