

Series EHD 241-451

DN40 PN315

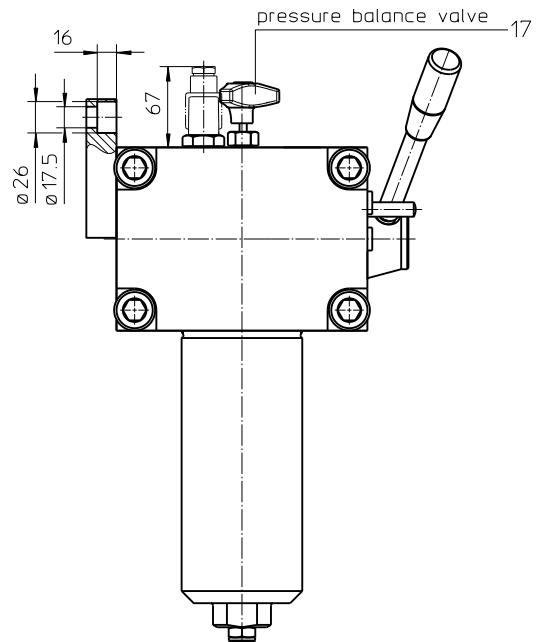
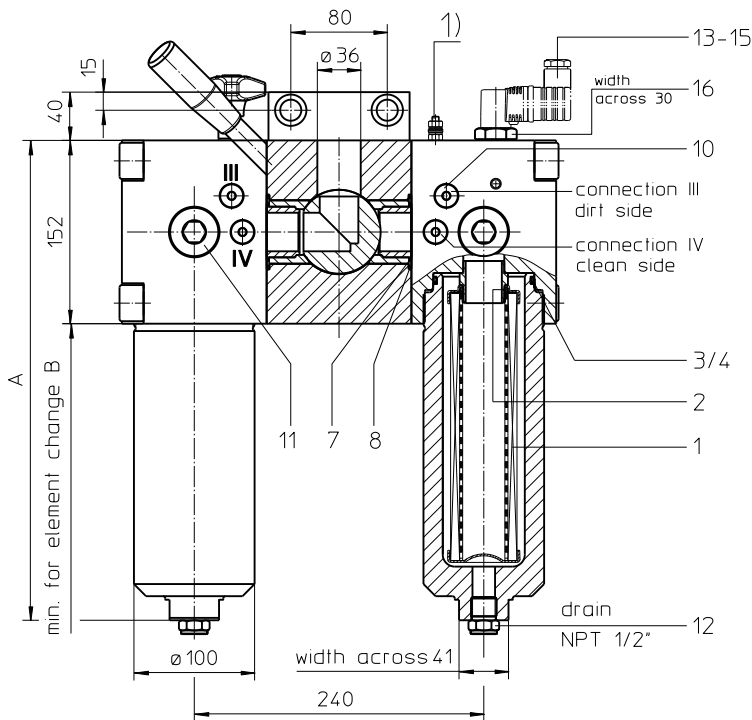

- 1) Connection for the potential equalization, only for application in the explosive area.

Connections III and IV to be used for pressure relief and air bleeding respective filter side.

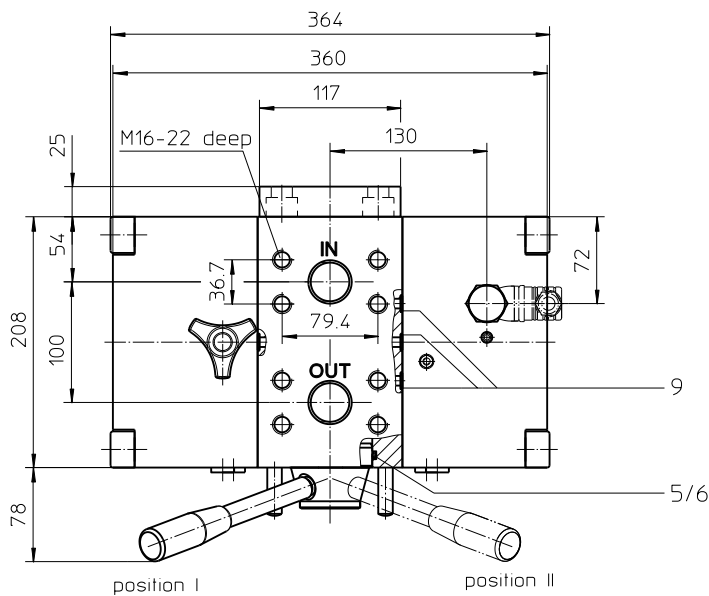

Dimensions:

type	EHD 241	EHD 451
connection		SAE 1 1/2"
A	398	583
B	340	525
weight kg	101	112
volume tank	2x 0,85 l	2x 1,55 l

Position I: left filter side in operation
 Position II: right filter side in operation

mm

Designs and performance values are subject to change.

EDV 08/19

For more information:

WEB: FLTR.com.au PHONE: (+61) 1300 62 4020 EMAIL: info@FLTR.com.au SKYPE: Purple.Engineering

Pressure Filter, change over Series EHD 241-451 DN40 PN315

Description:

Stainless steel-pressure filters changeover series EHD 241-451 are suitable for operating pressure up to 315 bar. The pressure peaks are absorbed by a sufficient margin of safety.

Duplex filters can be serviced without interruption of operation. The upper part has a three-way-change-over valve which allows to change-over the flow from the dirty filter-side to the clean filter-side without interrupting the operation. The change-over procedure does not lead to a cross sectional contraction. Prior to the change-over procedure a built-in pressure balance valve equalizes the housing pressure. After change-over the pressure balance valve is to be closed again. The closed filter-side has to be air-bled by vent III respectively by vent IV. Then change filter element. After screw in the filter bowl the pressure balance has to be opened shortly and the just serviced filter-side has to be air-bled. Filter elements are available down to a filter fineness of 5 $\mu\text{m}_{(C)}$.

Eaton filter elements are known for high intrinsic stability and an excellent filtration capability, a high dirt-retaining capacity and a long service life.

Eaton filter elements are available with a pressure difference resistance up to Δp 160 bar and a rupture strength up to Δp 250 bar.

The internal valves are integrated into the centering pivot for the filter element.

After reaching the opening pressure the by-pass valve causes that an unfiltered partial flow passes the filter. The reversing valve provides another level of protection for the filter element. The reverse flow will not be filtered.

Eaton filter are suitable for all petroleum based fluids, HW-emulsions, most synthetic hydraulic fluids and lubrication oils.

Type index:

Complete filter: (ordering example)

EHD. 241. 10VG. HR. E. P. VA. FS. 7. VA. - . - . AE

1	2	3	4	5	6	7	8	9	10	11	12	13
---	---	---	---	---	---	---	---	---	----	----	----	----

- | | |
|----|--|
| 1 | series:
EHD = stainless steel-pressure filter change over |
| 2 | nominal size: 241, 451 |
| 3 | filter material:
80G, 40G, 25G stainless steel wire mesh
25VG, 16VG, 10VG, 6VG, 3VG microglass |
| 4 | filter element collapse rating:
30 = Δp 30 bar
HR = Δp 160 bar (rupture strength Δp 250 bar) |
| 5 | filter element design:
E = single-end open |
| 6 | sealing material:
P = Nitrile (NBR)
V = Viton (FPM) |
| 7 | filter element specification:
- = standard
VA = stainless steel |
| 8 | process connection:
FS = SAE-flange connection 3000 PSI |
| 9 | process connection size:
7 = 1 1/2" (DN40) |
| 10 | filter housing specification:
VA = stainless steel |
| 11 | specification pressure vessel:
- = standard (PED 2014/68/EU)
IS20 = ASME VIII Div.1 with ASME equivalent material, see sheet-no. 55217 (max. operating pressure 250 bar) |
| 12 | internal valve:
- = without
S1 = with bypass valve Δp 3,5 bar
S2 = with bypass valve Δp 7,0 bar
R = reversing valve, $Q \leq 211,008$ l/min |
| 13 | clogging indicator or clogging sensor:
- = without
AOR = visual, see sheet-no. 1606
AOC = visual, see sheet-no. 1606
AE = visual-electric, see sheet-no. 1615
VS5 = electronic, see sheet-no. 1619 |

To add an indicator/sensor to your filter, use the corresponding indicator data sheet to find the indicator details and add them to the filter assembly model code.

Filter element: (ordering example)

01E. 240. 10VG. HR. E. P. VA

1	2	3	4	5	6	7
---	---	---	---	---	---	---

- | | |
|---|--|
| 1 | series:
01E = filter element according to company standard |
| 2 | nominal size: 240, 450 |
| 3 | - 7 see type index-complete filter |

Accessories:

- gauge port- and bleeder connections, see sheet-no. 1650

Technical data:

operating temperature:	-10°C to +100°C
operating medium:	mineral oil, other media on request
max. operating pressure:	315 bar
test pressure:	450 bar
max. operating pressure at IS20:	250 bar
test pressure at IS20:	325 bar
process connection:	SAE-flange 3000 PSI
housing material:	EN10088-1.4571 (320 S 18, 320 S 31 according to B.S.)
sealing material:	Nitrile (NBR) or Viton (FPM), other materials on request
installation position:	vertical
measuring- and bleeder connections dirt side:	G ¼

Classified under the Pressure Equipment Directive 2014/68/EU for mineral oil (fluid group 2), Article 4, Para. 3.
Classified under ATEX Directive 2014/34/EU according to specific application (see questionnaire sheet-no. 34279-4).

Pressure drop flow curves:

Filter calculation/sizing

The pressure drop of the assembly at a given flow rate Q is the sum of the housing Δp and the element Δp and is calculated as follows:

$$\Delta p_{assembly} = \Delta p_{housing} + \Delta p_{element}$$

$$\Delta p_{housing} = (\text{see } \Delta p = f(Q) \text{ - characteristics})$$

$$\Delta p_{element} (mbar) = Q \left(\frac{l}{min} \right) \times \frac{MSK (mbar)}{10 \left(\frac{l}{min} \right)} \times v \left(\frac{mm^2}{s} \right) \times \frac{p}{0,876} \left(\frac{kg}{dm^3} \right)$$

For ease of calculation our Filter Selection tool is available online at www.eatonpowersource.com/calculators/filtration/

Material gradient coefficients (MSK) for filter elements

The material gradient coefficients in mbar/(l/min) apply to mineral oil (HLP) with a density of 0,876 kg/dm³ and a kinematic viscosity of 30 mm²/s (139 SUS). The pressure drop changes proportionally to the change in kinematic viscosity and density.

EHD	VG					G		
	3VG	6VG	10VG	16VG	25VG	25G	40G	80G
241	1,685	1,170	0,749	0,652	0,446	0,0531	0,0496	0,0340
451	0,907	0,630	0,403	0,351	0,240	0,0285	0,0266	0,0182

$\Delta p = f(Q)$ – characteristics according to ISO 3968

The pressure drop characteristics apply to mineral oil (HLP) with a density of 0,876 kg/dm³. The pressure drop changes proportionally to the density.

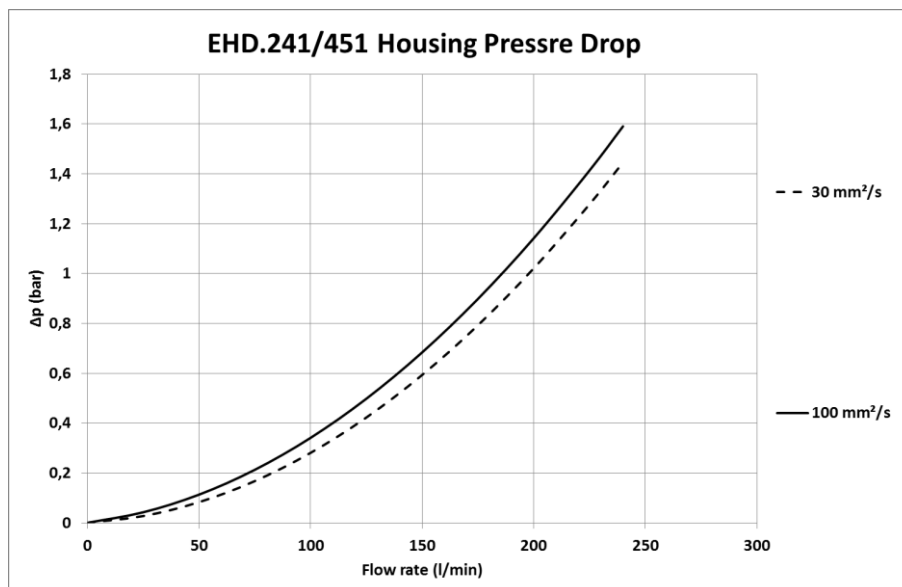

For more information:

WEB: FLTR.com.au PHONE: (+61) 1300 62 4020 EMAIL: info@FLTR.com.au SKYPE: Purple.Engineering

Symbols:

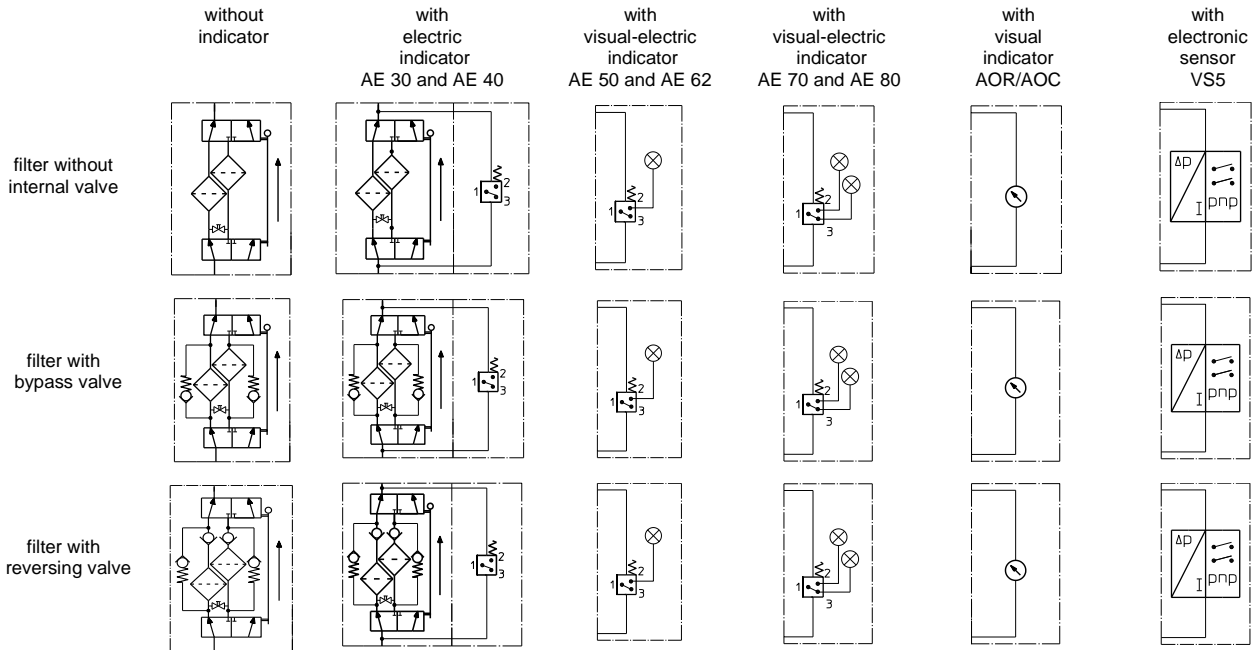

Spare parts:

item	qty.	designation	dimension		article-no.	
			EHD 241 01E.240...	EHD 451 01E.450...		
1	2	filter element				
2	2	O-ring	34 x 3,5		304338 (NBR)	304730 (FPM)
3	2	O-ring	76 x 4		305599 (NBR)	310291 (FPM)
4	2	support ring	84 x 3,2 x 1,5		312309	
5	3	O-ring	70 x 4		306253 (NBR)	310280 (FPM)
6	2	support ring	076 x 70 x 45°		317709	
7	4	O-ring	56 x 3		305072 (NBR)	305322 (FPM)
8	4	O-ring	42,52 x 2,62		304352 (NBR)	304392 (FPM)
9	4	O-ring	10 x 2		309998 (NBR)	310272 (FPM)
10	4	screw plug	G ¼		306968	
11	4	screw plug	G 1		308498	
12	2	screw plug	NPT ½"		307766	
13	1	clogging indicator, visual	AOR or AOC		see sheet-no. 1606	
14	1	clogging indicator, visual-electric	AE		see sheet-no. 1615	
15	1	clogging sensor, electronic	VS5		see sheet-no. 1619	
16	1	screw plug	20913-4		314442	
17	1	pressure balance valve	DN10		310316	

item 16 execution only without clogging indicator or clogging sensor

Test methods:

Filter elements are tested according to the following ISO standards:

ISO 2941	Verification of collapse/burst resistance
ISO 2942	Verification of fabrication integrity
ISO 2943	Verification of material compatibility with fluids
ISO 3723	Method for end load test
ISO 3724	Verification of flow fatigue characteristics
ISO 3968	Evaluation of pressure drop versus flow characteristics
ISO 16889	Multi-pass method for evaluating filtration performance

For more information:

WEB: FLTR.com.au PHONE: (+61) 1300 62 4020 EMAIL: info@FLTR.com.au SKYPE: Purple.Engineering