

Series EHP 31 PN 800/1400

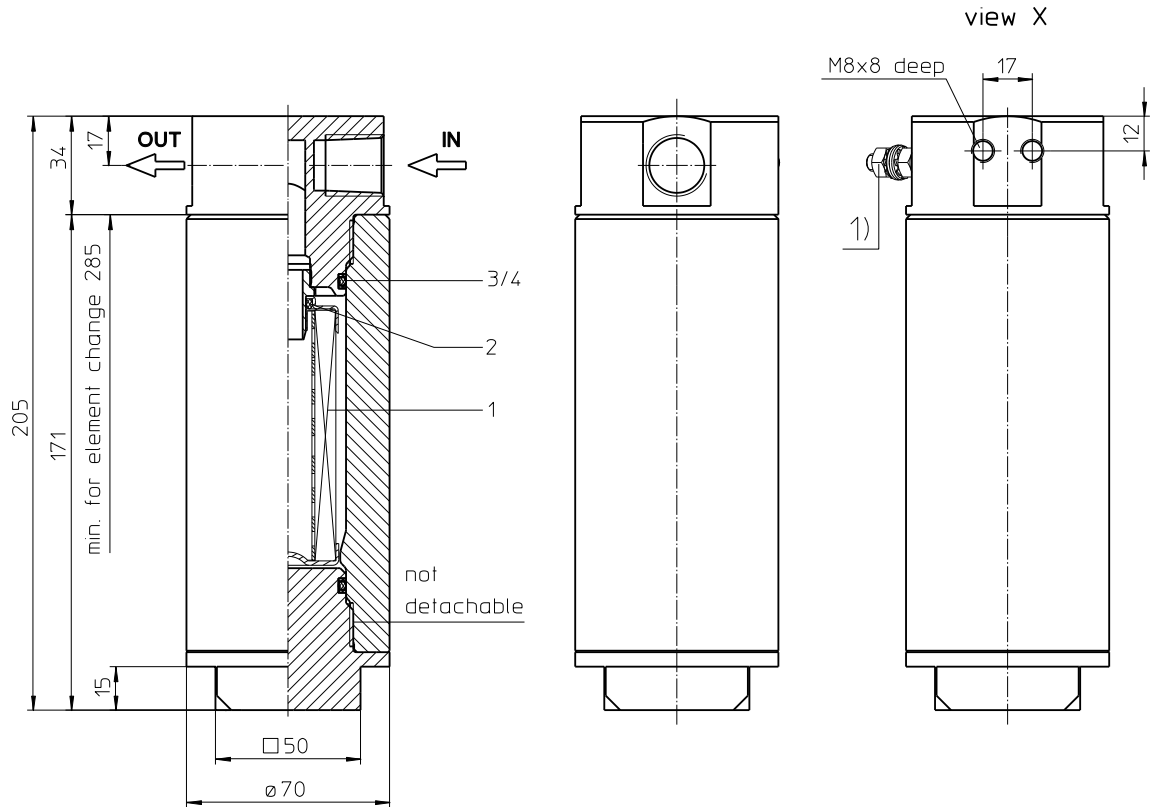

1) Connection for the potential equalization, only for application in the explosive area.

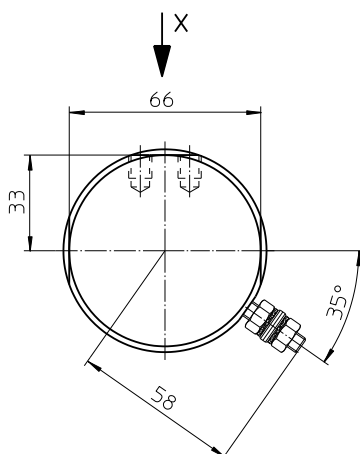

Weight: approx. 6 kg

Dimensions: mm

Designs and performance values are subject to change.

EDV 01/20

For more information:

WEB: FLTR.com.au PHONE: (+61) 1300 62 4020 EMAIL: info@FLTR.com.au SKYPE: Purple.Engineering

Stainless Steel-Pressure Filter

Series EHP 31

PN 800/1400

Description:

Stainless steel pressure filter series EHP 31 have a working pressure up to 800 bar or 1400 bar. Pressure peaks can be absorbed with a sufficient safety margin. The EHP-filter is in-line mounted.

The filter element consists of star-shaped, pleated filter material, which is supported on the inside by a perforated core tube and is bonded to the end caps with a high-quality adhesive. The flow direction is from outside to inside. Filter elements are available down to 5 $\mu\text{m}_{(c)}$. Finer filtration is available upon request.

Eaton filter elements are known for high intrinsic stability and an excellent filtration capability, a high dirt-retaining capacity and a long service life.

Eaton filter elements are available up to a pressure resistance of Δp 2320 PSI and a rupture strength of Δp 3625 PSI.

Eaton filter can be used for petroleum-based fluids, HW emulsions, water glycols, most synthetic fluids and lubrication fluids. Consult factory for specific fluid applications.

The internal valve is integrated into the filter head. After reaching the bypass pressure setting, the bypass valve will send unfiltered partial flow around the filter.

Type index:

Complete filter: (ordering example)

EHP. 31. 10VG. HR. E. P. VA. NPT. 3. -. VA. 800

1	2	3	4	5	6	7	8	9	10	11	12
---	---	---	---	---	---	---	---	---	----	----	----

- 1 | **series:**
EHP = stainless steel-pressure filter
- 2 | **nominal size:** 31
- 3 | **filter-material:**
80G, 40G, 25G , stainless steel wire mesh
25VG, 16VG, 10VG, 6VG, 3VG microglass
- 4 | **filter element collapse rating:**
30 = Δp 30 bar
HR = Δp 160 bar (rupture strength Δp 250 bar)
- 5 | **filter element design:**
E = single-end open
- 6 | **sealing material:**
P = Nitrile (NBR)
V = Viton (FPM)
- 7 | **filter element specification:**
- = standard
VA = stainless steel
IS06 = for HFC application, see sheet-no. 31601
- 8 | **process connection:**
UG2 = autoclave medium pressure
NPT = thread connection
- 9 | **process connection size:**
1 = MP 3/8" (9/16"-18UNF)
3 = NPT 1/2"
- 10 | **internal valve:**
- = without
S1 = with by-pass valve Δp 3,5 bar
S2 = with by-pass valve Δp 7,0 bar
- 11 | **filter housing specification:**
VA = stainless steel
- 12 | **pressure level:**
800 = max. operating pressure 800 bar
1400 = max. operating pressure 1400 bar

Filter element: (ordering example)

01E. 30. 10VG. HR. E. P. VA

1	2	3	4	5	6	7
---	---	---	---	---	---	---

- 1 | **series:**
01E. = filter element according to company standard
- 2 | **nominal size:** 30
- 3 | - | 7 | see type index-complete filter

Technical data:

operating temperature:	-10 °C bis +100 °C				
operating medium:	mineral oil, other media on request				
max. operating pressure:	<table border="1"> <tr> <td>800 bar</td> <td>1400 bar</td> </tr> </table>	800 bar	1400 bar		
800 bar	1400 bar				
test pressure:	<table border="1"> <tr> <td>1145 bar</td> <td>2000 bar</td> </tr> </table>	1145 bar	2000 bar		
1145 bar	2000 bar				
process connection:	thread connection				
housing material:	<table border="1"> <tr> <td>EN10088-3 - 1.4462</td> <td>800 bar</td> </tr> <tr> <td>EN10088-3 - 1.4418 + QT900</td> <td>1400 bar</td> </tr> </table>	EN10088-3 - 1.4462	800 bar	EN10088-3 - 1.4418 + QT900	1400 bar
EN10088-3 - 1.4462	800 bar				
EN10088-3 - 1.4418 + QT900	1400 bar				
sealing material:	Nitrile (NBR) or Viton (FPM), other materials on request				
installation position:	vertical				
volume tank:	0,12 l				

Pressure stage 800: Classified under the Pressure Equipment Directive 2014/68/EU for mineral oil (fluid group 2), Article 4, Para. 3.
 Pressure stage 1400: Classified under the Pressure Equipment Directive 2014/68/EU for mineral oil (fluid group 2), Category I (Modul A)
 Classified under ATEX Directive 2014/34/EU according to specific application (see questionnaire sheet-no. 34279-4).

Pressure drop flow curves:

Filter calculation/sizing

The pressure drop of the assembly at a given flow rate Q is the sum of the housing Δp and the element Δp and is calculated as follows:

$$\Delta p_{assembly} = \Delta p_{housing} + \Delta p_{element}$$

$$\Delta p_{housing} = (\text{see } \Delta p = f(Q) \text{ - characteristics})$$

$$\Delta p_{element} (mbar) = Q \left(\frac{l}{min} \right) \times \frac{MSK (mbar)}{10 (l/min)} \times v \left(\frac{mm^2}{s} \right) \times \frac{p}{0,876} \left(\frac{kg}{dm^3} \right)$$

For ease of calculation our Filter Selection tool is available online at www.eatonpowersource.com/calculators/filtration/

Material gradient coefficients (MSK) for filter elements

The material gradient coefficients in mbar/(l/min) apply to mineral oil (HLP) with a density of 0,876 kg/dm³ and a kinematic viscosity of 30 mm²/s (139 SUS). The pressure drop changes proportionally to the change in kinematic viscosity and density.

EHP	VG					G		
	3VG	6VG	10VG	16VG	25VG	25G	40G	80G
31	10,116	7,023	4,496	3,915	2,674	0,2073	0,1935	0,1325

$\Delta p = f(Q)$ – characteristics according to ISO 3968

The pressure drop characteristics apply to mineral oil (HLP) with a density of 0,876 kg/dm³. The pressure drop changes proportionally to the density.

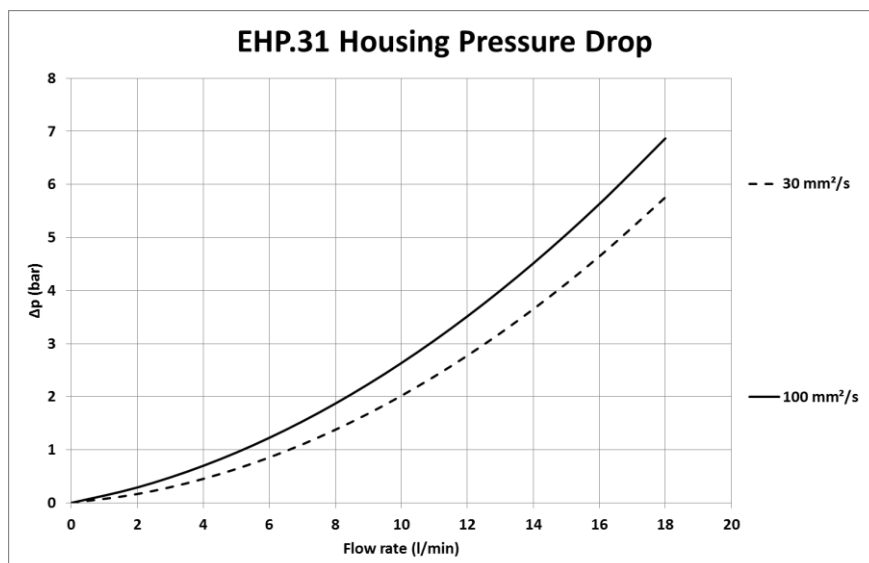

For more information:

WEB: FLTR.com.au PHONE: (+61) 1300 62 4020 EMAIL: info@FLTR.com.au SKYPE: Purple.Engineering

Symbols:

filter without by-pass valve

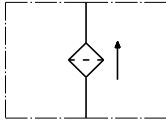

filter with by-pass valve

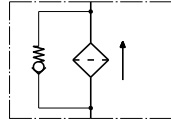

Spare parts:

item	qty.	designation	dimension	article-no.	
1	1	filer element	01E.30....		
2	1	O-ring	11 x 3	312603 (NBR)	312727 (FPM)
3	1	O-ring	34 x 3	330601 (NBR)	340165 (FPM)
4	2	support ring	40 x 2,6 x 1	330602	

Test methods:

Filter elements are tested according to the following ISO standards:

ISO 2941	Verification of collapse/burst resistance
ISO 2942	Verification of fabrication integrity
ISO 2943	Verification of material compatibility with fluids
ISO 3723	Method for end load test
ISO 3724	Verification of flow fatigue characteristics
ISO 3968	Evaluation of pressure drop versus flow characteristics
ISO 16889	Multi-pass method for evaluating filtration performance

For more information:

WEB: FLTR.com.au PHONE: (+61) 1300 62 4020 EMAIL: info@FLTR.com.au SKYPE: Purple.Engineering