

Series ELA 403

NPS 2" CLASS 150-300 PSI

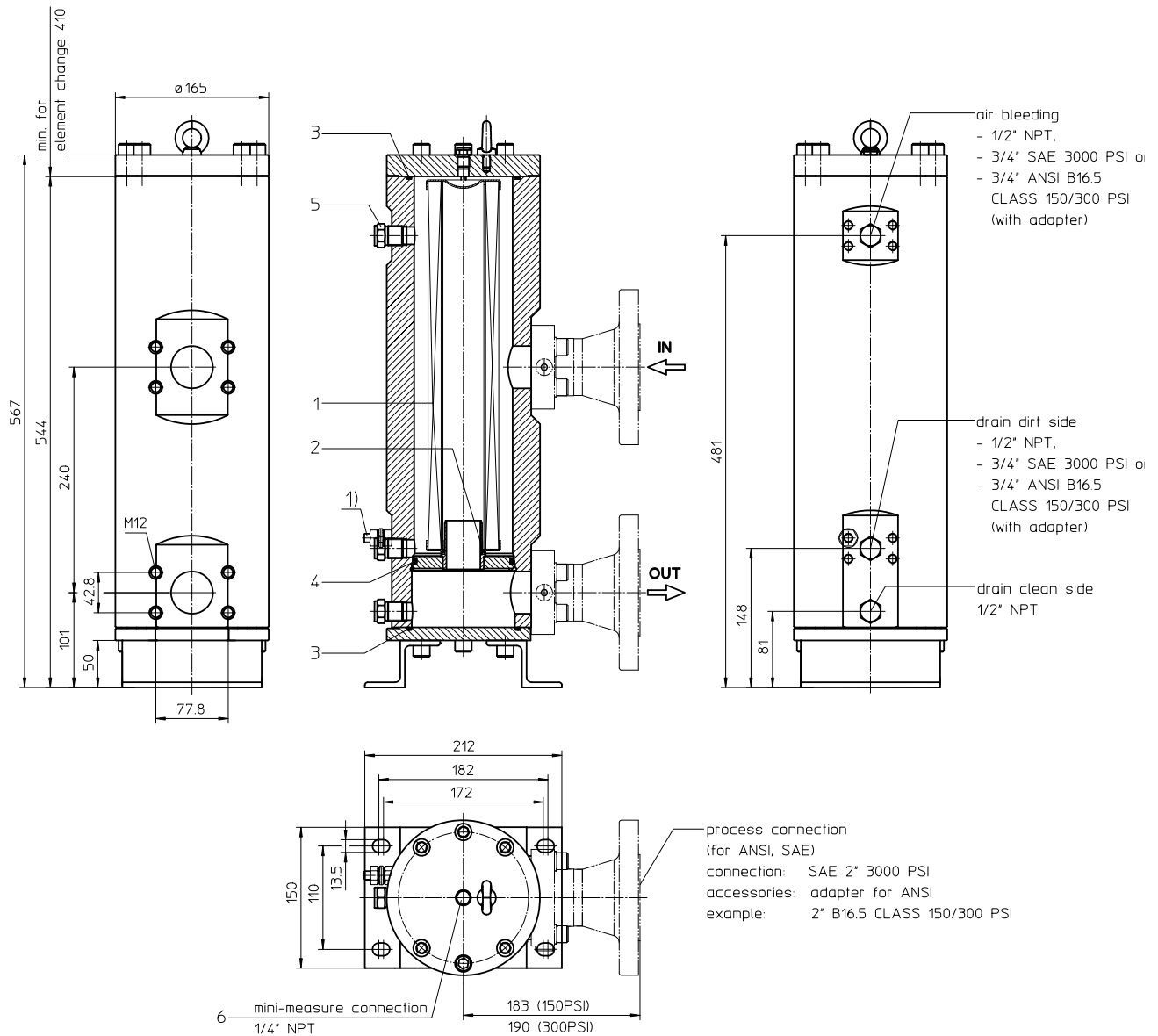

Weight: approx. 56 kg

Dimensions: mm

Designs and performance values are subject to change.

EDV 03/19

For more information:

WEB: FLTR.com.au PHONE: (+61) 1300 62 4020 EMAIL: info@FLTR.com.au SKYPE: Purple.Engineering

Pressure Filter

Series ELA 403

NPS 2" CLASS 150-300 PSI

Description:

Stainless steel-inline filter series ELA 403 have a working pressure up to 40 bar. Pressure peaks can be absorbed with a sufficient safety margin.

The filter element consists of star-shaped, pleated filter material which is supported on the inside by a perforated core tube and is bonded to the end caps with a high-quality adhesive. The flow direction is from outside to inside.

For cleaning the stainless steel mesh element (see special leaflets 21070-4 and 39448-4) or changing the filter element, remove the cover and take out the element. The mesh elements are not guaranteed to maintain 100% performance after cleaning.

For filtration finer than 40 µm use disposable elements made of microglass. Filter elements as fine as 5 µm(c) are available; finer filter elements are available upon request.

Eaton filter elements are known for a high intrinsic stability and an excellent filtration capability, a high dirt-retaining capacity and a long service life.

Eaton filter elements are suitable for all petroleum based fluids, HW-emulsions, most synthetic hydraulic fluids and lubrication oils.

Ship classifications available upon request.

Type index:

Complete filter: (ordering example)

ELA. 403. 10VG. 30. E. P. VA. FS. 8. VA. IS21.

1	2	3	4	5	6	7	8	9	10	11
---	---	---	---	---	---	---	---	---	----	----

12	13
----	----

- 1 series:**
ELA = stainless steel-inline filter according to ASME-code
- 2 nominal size:** 403
- 3 filter material:**
80G, 40G, 25G, 10G stainless steel wire mesh
25VG, 16VG, 10VG, 6VG, 3VG microglass
25API, 10API microglass according to API
- 4 filter element collapse rating:**
30 = Δp 30 bar
- 5 filter element design:**
E = single-end open
S = with by-pass valve Δp 2,0 bar
S1 = with by-pass valve Δp 3,5 bar
- 6 sealing material:**
P = Nitrile (NBR)
V = Viton (FPM)
- 7 filter element specification:**
- = standard
VA = stainless steel
- 8 process connection:**
FS = flange SAE 3000 PSI
FA1 = flange ANSI CLASS 300 PSI,
sealing surface Rz = 160 µm (not finer than 40 µm)
FA2 = flange ANSI CLASS 300 PSI, sealing surface Rz = 16 µm
FA11 = flange ANSI CLASS 150 PSI,
sealing surface Rz = 160 µm (not finer than 40 µm)
FA12 = flange ANSI CLASS 150 PSI, sealing surface Rz = 16 µm
- 9 process connection size:**
8 = 2"
- 10 filter housing specification:**
VA = stainless steel, see sheet-no. 68599
- 11 specification pressure vessel:**
IS21 = ASME VIII Div.1 with U-stamp, see sheet-no. 43415
IS23 = ASME VIII Div.1 without U-stamp, see sheet-no. 55218
- 12 shut-off :**
- = without
- 13 clogging indicator:**
- = without

Filter element: (ordering example)

01NL. 400. 10VG. 30. E. P. VA

1	2	3	4	5	6	7
---	---	---	---	---	---	---

- 1 series:**
01NL = standard filter element according to DIN 24550, T3
- 2 nominal size:** 400
- 3 - 7** see type index-complete filter

For more information:

WEB: FLTR.com.au **PHONE:** (+61) 1300 62 4020 **EMAIL:** info@FLTR.com.au **SKYPE:** Purple.Engineering



Technical data:

operating temperature:	-10°C to +100°C
operating medium:	mineral oil, other media on request
max. operating pressure (pressure vessel):	40 bar
test pressure acc. to ASME VIII Div. 1:	1,3 x operating pressure = 52 bar
test pressure acc. to API 614, Chapter 1:	1,5 x operating pressure = 60 bar
process connection:	SAE-flange 3000 PSI or ANSI-flange B16.5 CLASS 150/300 PSI
housing material:	stainless steel, see sheet-no. 68599
sealing material:	Nitrile (NBR) or Viton (FPM), other materials on request
installation position:	vertical
bleeder connection:	NPT ½" or SAE ¾" 3000 PSI
drain connection dirt side:	NPT ½" or SAE ¾" 3000 PSI
drain connection clean side:	NPT ½"
volume tank:	4,3 l
operating pressure adapter flanges:	according to B16.5 CLASS 150 PSI (max. 16 bar) according to B16.5 CLASS 300 PSI (max. 40 bar)

Classified under the Pressure Equipment Directive 2014/68/EU for mineral oil (fluid group 2), Article 4, Para. 3. Classified under ATEX Directive 2014/34/EU according to specific application (see questionnaire sheet-no. 34279-4)

Pressure drop flow curves:

Filter calculation/sizing

The pressure drop of the assembly at a given flow rate Q is the sum of the housing Δp and the element Δp and is calculated as follows:

$$\Delta p_{assembly} = \Delta p_{housing} + \Delta p_{element}$$

$$\Delta p_{housing} = (\text{see } \Delta p = f(Q) - \text{characteristics})$$

$$\Delta p_{Element} (mbar) = Q \left(\frac{l}{min} \right) \times \frac{MSK (mbar)}{10 \left(\frac{l}{min} \right)} \times v \left(\frac{mm^2}{s} \right) \times \frac{\rho (kg)}{0,876 \left(\frac{kg}{dm^3} \right)}$$

For ease of calculation our Filter Selection tool is available online at www.eatonpowersource.com/calculators/filtration/

Material gradient coefficients (MSK) for filter elements

The material gradient coefficients in mbar/(l/min) apply to mineral oil (HLP) with a density of 0,876 kg/dm³ and a kinematic viscosity of 30 mm²/s (139 SUS). The pressure drop changes proportionally to the change in kinematic viscosity and density.

ELA	VG					G				API	
	3VG	6VG	10VG	16VG	25VG	10G	25G	40G	80G	10 API	25 API
403	0,571	0,397	0,254	0,221	0,151	0,0228	0,0169	0,0158	0,0108	0,130	0,059

$\Delta p=f(Q)$ – characteristic according ISO 3968

The pressure drop characteristics apply to mineral oil (HLP) with a density of 0,876 kg/dm³. The pressure drop changes proportionally to the density.

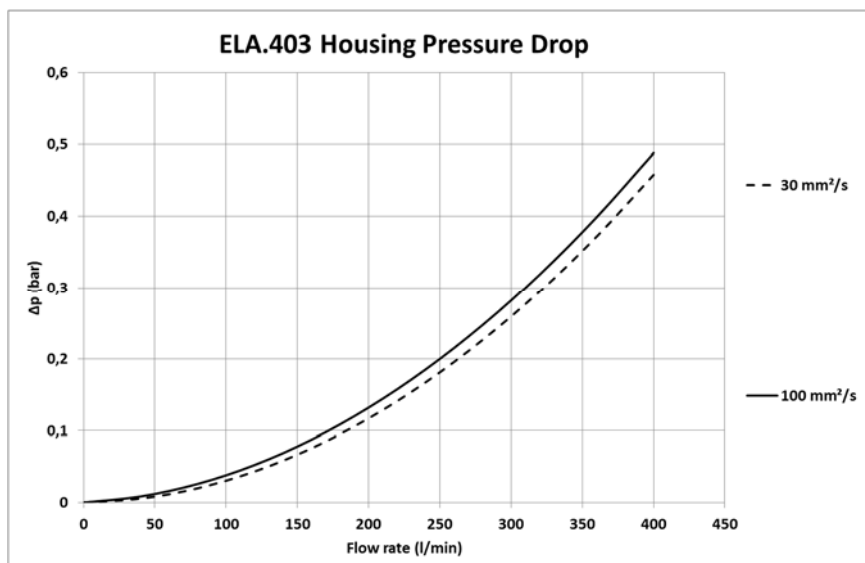

For more information:

WEB: FLTR.com.au PHONE: (+61) 1300 62 4020 EMAIL: info@FLTR.com.au SKYPE: Purple.Engineering

Symbols:

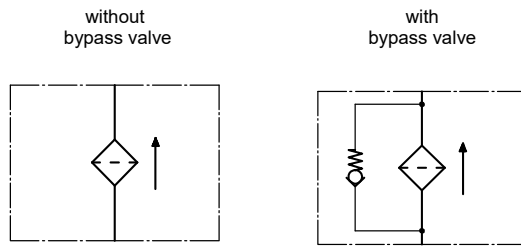

Spare parts:

item	qty.	designation	dimension	article-no.	
1	2	filter element	01NL.400...		
2	1	O-ring	40 x 3	304389 (NBR)	304391 (FPM)
3	2	O-ring	115 x 3,55	350198 (NBR)	350197 (FPM)
4	1	O-ring	100 x 5	327063 (NBR)	327064 (FPM)
5	3	screw plug	NPT 1/2"	307766	
6	1	screw plug	NPT 1/4"	325296	

Test methods:

Filter elements are tested according to the following ISO standards:

ISO 2941	Verification of collapse/burst resistance
ISO 2942	Verification of fabrication integrity
ISO 2943	Verification of material compatibility with fluids
ISO 3723	Method for end load test
ISO 3724	Verification of flow fatigue characteristics
ISO 3968	Evaluation of pressure drop versus flow characteristics
ISO 16889	Multi-pass method for evaluating filtration performance

For more information:

WEB: FLTR.com.au PHONE: (+61) 1300 62 4020 EMAIL: info@FLTR.com.au SKYPE: Purple.Engineering