

# STAINLESS STEEL-PRESSURE FILTER

## Series ELF 1201-10001 DN 50-250 PN 16

Sheet No.  
**1130 C**

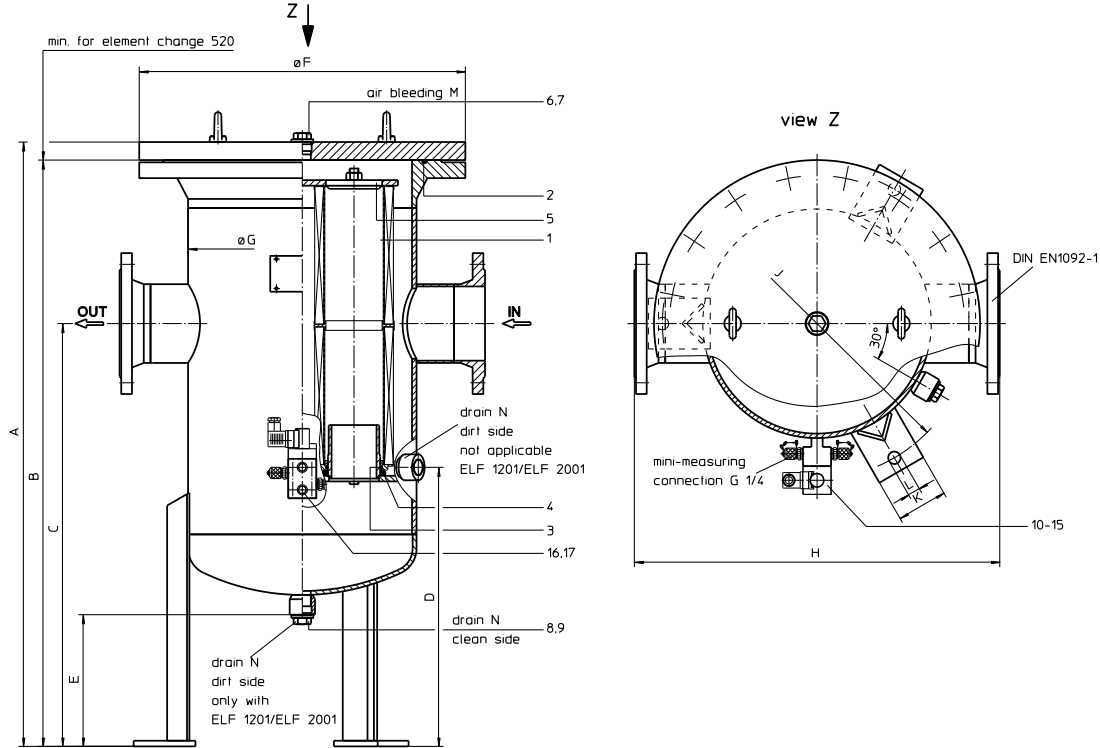

### 3. Dimensions:

type	connection DN	A	B	C	D	E	F	G	H	J	K	L	M	N	weight kg	volume tank
ELF 1201	50	1052	1028	400	-	188	340	219	412	330	70	18	G 1/2	G1	60	26,0 l
	65	1071	1047													27,0 l
	80	1052	1028													26,0 l
	100	1128	1104													29,0 l
ELF 2001	65	1093	1067	425	-	186	405	273	494	380	70	18	G1	G1	110	43,5 l
	80	1112	1086													44,5 l
	100	1100	1074													43,5 l
	125	1188	1162													48,0 l
ELF 2401	65	1018	990	700	445	183	460	324	600	450	70	18	G1	G1	130	55,0 l
	80															
	100															
	125															
ELF 3601	80	1072	1040	750	495	238	580	406	650	550	90	22	G1	G1	260	90,0 l
	100															
	125															
	150															
ELF 4801 ELF 6001	100	1116	1080	800	535	232	715	508	800	650	90	22	G1	G1	310	145,0 l
	125															
	150															
	200															
ELF 10001	125	1425	1110	800	570	283	910	711	1000	900	120	22	G1 1/2	G1 1/2	560	283,0 l
	150															
	200															
	250															

### 1. Type index:

#### 1.1. Complete filter: (ordering example)

**ELF. 2001. 10VG. 10. E. P. VA. FD1. 9. -. AE**

1	2	3	4	5	6	7	8	9	10	11
---	---	---	---	---	---	---	---	---	----	----

- series:**  
ELF = stainless steel-in-line filter
- nominal size:** 1201, 2001, 2401, 3601, 4801, 6001, 10001
- filter material and filter fineness:**  
80 G = 80 µm, 40 G = 40 µm, 25 G = 25 µm stainless steel wire mesh,  
25 VG = 20 µm<sub>(c)</sub>, 16 VG = 15 µm<sub>(c)</sub>, 10 VG = 10 µm<sub>(c)</sub>, 6 VG = 7 µm<sub>(c)</sub>, 3 VG = 5 µm<sub>(c)</sub> Interpor fleece (glass fibre)  
25 API = 20 µm, 10 API = 10 µm Interpor fleece (glass fibre) according to API
- resistance of pressure difference for filter element:**  
10 = Δp 10 bar
- filter element design:**  
E = without by-pass valve; S = with by-pass valve Δp 2,0 bar
- sealing material:**  
P = Nitrile (NBR); V = Viton (FPM)
- filter element specification:** (see catalog)  
- = standard; VA = stainless steel  
IS06 = see sheet-no. 31601
- connection:**  
FD1 = flange connection DIN EN1092-1, design B1  
FD2 = flange connection DIN EN1092-1, design B2
- connection size:**

DN	filter nominal size									
8 = 50	1201									
9 = 65	1201	2001	2401							
A = 80	1201	2001	2401	3601						
B = 100	1201	2001	2401	3601	4801	6001				
C = 125		2001	2401	3601	4801	6001	10001			
D = 150				3601	4801	6001	10001			
E = 200					4801	6001	10001			
F = 250							10001			

#### 10 filter housing specification:

- = stainless steel

#### 11 clogging indicator or clogging sensor:

- = without

AE = visual-electrical, see sheet-no.1609

OP = visual, see sheet-no.1628;

VS1 = electronical, see sheet-no.1607

OE = visual-electrical, see sheet-no 1628;

VS2 = electronical, see sheet-no.1608

### 1.2. Filter element: (ordering example)

**01E. 2001. 10VG. 10. E. P. VA**

1	2	3	4	5	6	7
---	---	---	---	---	---	---

#### 1 series:

01E. = filter element according to company standard

#### 2 nominal size: 1201, 2001

3 - 7 see type index-complete filter

### 2. Accessories:

- measure-and bleeder-connection see sheet-no. 1650

- evacuation- and bleeder-connection see sheet-no. 1651

- counter flange see sheet-no. 1653

- lifting mechanism, see sheet-no. 1661

Changes of measures and design are subject to alteration!



For more information: WEB: FLTR.com.au PHONE: (+61) 1300 62 4020

EMAIL: info@FLTR.com.au SKYPE: Purple.Engineering

## 4. Spare parts:

### 4.1. Depending on different series:

item	designation	qty.	dimension and article-no. ELF 1201	dimension and article-no. ELF 2001	qty.	dimension and article-no. ELF 2401	qty.	dimension and article-no. ELF 3601	qty.	dimension and article-no. ELF 4801	qty.	dimension and article-no. ELF 6001	dimension and article-no. ELF 10001	
1	filter element	1	01E.1201 225 x 5	01E.2001 275 x 5	2	01E.1201 330 x 5	3	01E.1201 429 x 6	4	01E.1201 516 x 6	3	01E.2001 516 x 6	5	01E.2001 722 x 8
2	O-ring	1	308652 (NBR) 311473 (FPM)	307414 (NBR) 310288 (FPM)	1	303080 (NBR) 310275 (FPM)	1	308659 (NBR) 310273 (FPM)	1	301962 (NBR) 311474 (FPM)	1	301962 (NBR) 311474 (FPM)	1	308145 (NBR) 311805 (FPM)
3	O-ring	1	93 x 5 307588 (NBR) 307589 (FPM)	135 x 5 306016 (NBR) 307045 (FPM)	2	93 x 5 307588 (NBR) 307589 (FPM)	3	93 x 5 307588 (NBR) 307589 (FPM)	4	93 x 5 307588 (NBR) 307589 (FPM)	3	135 x 5 306016 (NBR) 307045 (FPM)	5	135 x 5 306016 (NBR) 307045 (FPM)
4	O-ring	1	85 x 10 304386 (NBR) 304541 (FPM)	125 x 10 304388 (NBR) 306006 (FPM)	2	85 x 10 304386 (NBR) 304541 (FPM)	3	85 x 10 304386 (NBR) 304541 (FPM)	4	85 x 10 304386 (NBR) 304541 (FPM)	3	125 x 10 304388 (NBR) 306006 (FPM)	5	125 x 10 304388 (NBR) 306006 (FPM)
5	spring	1	324967		-	-	-	-	-	-	-	-	-	
	pressure plate	-	-		1	319252	1	319253	1	319354	1	319255	1	319256
6	screw plug	1	G ½ 310092	G 1 319275	1	G1 319275		1	G1 319275		1	G 1 ½ 329702		
7	gasket	1	A 22 x 27 320243	A 33 x 39 319276	1	A 33 x 39 319276		1	A 48 x 55 329700		1	A 48 x 55 329700		
8	screw plug	1	G 1 319275	G 1 319275	2	G1 319275		2	G 1 ½ 329702		2	G 1 ½ 329702		
9	gasket	1	A 33 x 39 319276	A 33 x 39 319276	2	A 33 x 39 319276		2	A 48 x 55 329700		2	A 48 x 55 329700		

### 4.2. Depending on the series:

item	qty.	designation	dimension	article-no.
10	1	clogging indicator, visual	OP	see sheet-no. 1628
11	1	clogging indicator, visual-electrical	OE	see sheet-no. 1628
12	1	clogging indicator, visual-electrical	AE	see sheet-no. 1609
13	1	clogging sensor, electronical	VS1	see sheet-no. 1607
14	1	clogging sensor, electronical	VS2	see sheet-no. 1608
15	2	O-ring	14 x 2	304342 (NBR)   304722 (FPM)
16	2	screw plug	G ½	313787
17	2	gasket	A 14 x 18	323449

## 5. Description:

In-line filters of the series ELF 1201-10001 are suitable for a working pressure up to 16 bar.

Pressure peaks can be absorbed with a sufficient margin of safety.

The filter is in-line mounted. Inlet and outlet are on the same level. The filters can be installed as suction-filter, pressure-filter or return-line filter.

The filter element consist of star-shaped, pleated filter material which is supported on the inside by a perforated core tube and is bonded to the end caps with a high-quality adhesive. The flow direction is from outside to the inside. The particles are hold back on the outside.

For cleaning (see special leaflet 21070-4 and 39448-4) the mesh element respectively to change the glass fibre element remove the cover and take out the element.

Filter finer than 40 microns should use throw-away elements made of paper or Interpor fleece (glass fibre). Filter elements as fine as 5 microns<sub>(c)</sub> are available; finer filter elements on request.

Internormen Product Line filter elements are known as elements with a high intrinsic stability and an excellent filtration capability, a high dirt-retaining capacity and a long service life.

Internormen Product Line filters are suitable for all petroleum based fluids, HW-emulsions, most synthetic hydraulic fluids and lubrication oils.

Approvals according to TÜV, and the major „Shipyards Classification Societies“ D.N.V.; B.V.; G.L.; L.R.S.; R.I.N.A.; A.B.S.; P.R.S.;USS.R.S. and others are possible.

## 6. Technical data:

temperature range:	- 10°C to +80°C (for a short time +100°C)
operating medium:	mineral oil, other media on request
max. operating pressure:	16 bar
test pressure:	23 bar
connection system:	flange connection DIN EN1092-1, 16 bar
housing material:	EN10088 - 1.4571 (320 S18, 320 S 31 according to B.S.)
sealing material:	Nitrile (NBR) or Viton (FPM), other materials on request
installation position:	vertical
mini-measuring connection:	G ¼

Classified under the Pressure Equipment Directive 97/23/EC for mineral oil (fluid group 2), Article 3, Para. 3.

Classified under ATEX Directive 94/9/EC according to specific application (see questionnaire sheet-no. 34279-4).

## 7. Symbols:

without indicator

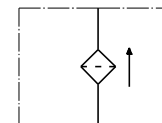

with visual - electrical indicator AE 50 and AE 62

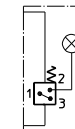

with visual indicator OP

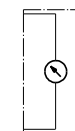

with electronical clogging sensor VS1

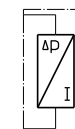

with electrical indicator AE 30 and AE 40

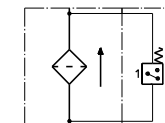

with visual - electrical indicator AE 70 and AE 80

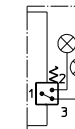

with visual - electrical indicator OE

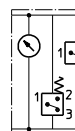

with electronical clogging sensor VS2



## 8. Pressure drop flow curves:

Precise flow rates see 'Internormen Product Specifier', respectively Δp-curves; depending on filter fineness and viscosity.

## 9. Test methods:

Filter elements are tested according to the following ISO standards:

ISO 2941	Verification of collapse/burst resistance
ISO 2942	Verification of fabrication integrity
ISO 2943	Verification of material compatibility with fluids
ISO 3723	Method for end load test
ISO 3724	Verification of flow fatigue characteristics
ISO 3968	Evaluation of pressure drop versus flow characteristics
ISO 16889	Multi-pass method for evaluating filtration performance