

Series HDD 170-450 DN40 PN315

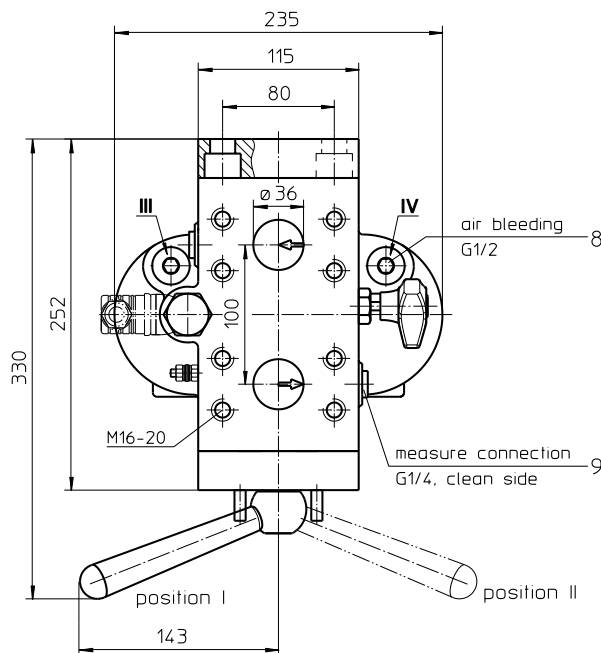
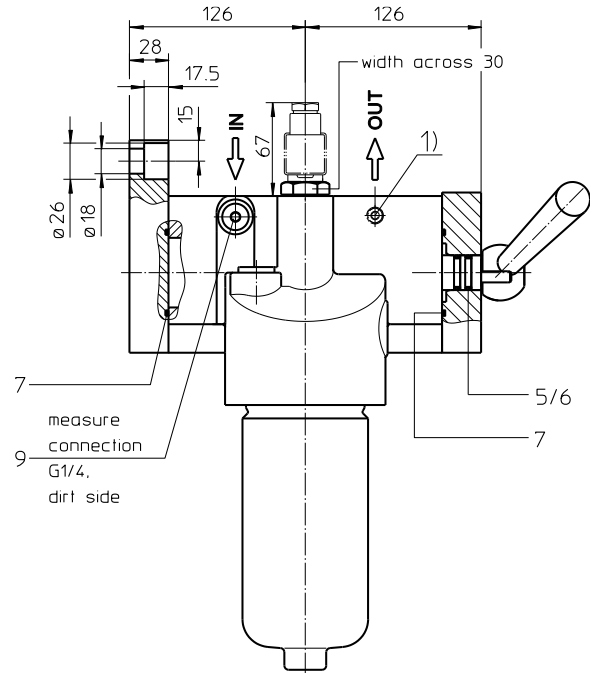
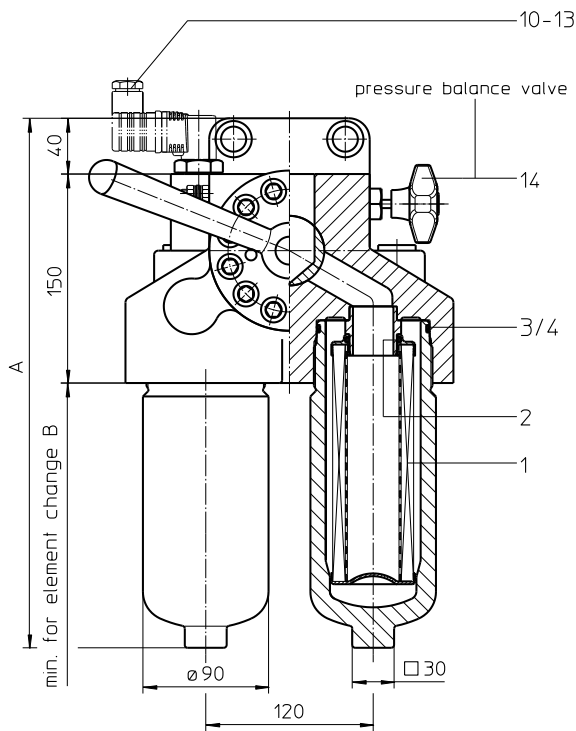

Dimensions:

type	connection	A	B	weight	volume tank
HDD 170	SAE 1 1/2"	380	350	38 kg	2x 0,7 l
HDD 240		430	400	40 kg	2x 0,9 l
HDD 360		510	480	45 kg	2x 1,2 l
HDD 450		615	585	50 kg	2x 1,6 l

1) Connection for the potential equalization, only for application in the explosive area.

Measure connections III and IV to be used for pressure relief and air bleeding respective filter side.

Position I: left filter side in operation
Position II: right filter side in operation

Dimensions: mm

Designs and performance values are subject to change.

Pressure Filter, change over Series HDD 170-450 DN40 PN315

Description:

Pressure filters change over series HDD 170-450 are suitable for operating pressure up to 315 bar. The pressure peaks are absorbed by a sufficient margin of safety.

Duplex filters can be serviced without interruption of operation. The upper part has a three-way-change-over valve which allows to change-over the flow from the dirty filter-side to the clean filter-side without interrupting the operation. The change-over procedure does not lead to a cross sectional contraction. Prior to the change-over procedure a built-in pressure balance valve equalizes the housing pressure. After change-over the pressure balance valve is to be closed again. The closed filter-side has to be air-bled by vent III respectively by vent IV. Then change filter element. After screw in the filter bowl the pressure balance has to be opened shortly and the just serviced filter-side has to be air-bled. Filter elements are available down to a filter fineness of $5 \mu\text{m}_{(C)}$.

Eaton filter elements are known for high intrinsic stability and an excellent filtration capability, a high dirt-retaining capacity and a long service life.

Eaton filter elements are available up to a pressure resistance of Δp 160 bar and a rupture strength of Δp 250 bar.

Eaton filter can be used for petroleum-based fluids, HW emulsions, water glycols, most synthetic fluids and lubrication fluids. Consult factory for specific fluid applications.

The internal valve is integrated into the filter head. After reaching the bypass pressure setting, the bypass valve will send unfiltered partial flow around the filter.

The reversing valve provides another level of protection for the filter element. The reverse flow will not be filtered.

Type index:

Complete filter: (ordering example)

HDD.	170.	10VG.	HR.	E.	P.	-.	FS.	7.	-.	-.	-.	AE
1	2	3	4	5	6	7	8	9	10	11	12	13

- 1 | **series:**
HDD = pressure filter change over
- 2 | **nominal size:** 170, 240, 360, 450
- 3 | **filter material:**
25VG, 16VG, 10VG, 6VG, 3VG microglass
- 4 | **filter element collapse rating:**
30 = Δp 30 bar
HR = Δp 160 bar (rupture strength Δp 250 bar)
- 5 | **filter element design:**
E = single-end open
- 6 | **sealing material:**
P = Nitrile (NBR)
V = Viton (FPM)
- 7 | **filter element specification:**
- = standard
VA = stainless steel
- 8 | **process connection:**
FS = SAE-flange connection 6000 PSI
- 9 | **process connection size:**
7 = 1 1/2"
- 10 | **filter housing specification:**
- = standard
- 11 | **specification pressure vessel:**
- = standard (PED 2014/68/EU)
IS20 = ASME VIII Div.1 with ASME equivalent material, see sheet no. 55217 (max. operating pressure 280 bar)
- 12 | **internal valve:**
- = without
S1 = with bypass valve Δp 3,5 bar
S2 = with bypass valve Δp 7,0 bar
R = reversing valve, $Q \leq 211,008$ l/min
- 13 | **clogging indicator or clogging sensor:**
- = without
AOR = visual, see sheet-no. 1606
AOC = visual, see sheet-no. 1606
AE = visual-electric, see sheet-no. 1615
VS5 = electronic, see sheet-no. 1619

To add an indicator/sensor to your filter, use the corresponding indicator data sheet to find the indicator details and add them to the filter assembly model code.

Filter element: (ordering example)

01E.	170.	10VG.	HR.	E.	P.	-
1	2	3	4	5	6	7

- 1 | **series:**
01E = filter element according to company standard
- 2 | **nominal size:** 170, 240, 360, 450
- 3 | - 7 | see type index-complete filter

Accessories:

- gauge port- and bleeder connections, see sheet-no. 1650

For more information:

WEB: FLTR.com.au **PHONE:** (+61) 1300 62 4020 **EMAIL:** info@FLTR.com.au **SKYPE:** Purple.Engineering



Technical data:

operating temperature:	-10 °C to +100 °C
operating medium:	mineral oil, other media on request
max. operating pressure:	315 bar
test pressure:	450 bar
max. operating pressure at IS20:	280 bar
test pressure at IS20:	364 bar
process connection:	SAE-flange 6000 PSI
housing material:	EN-GJS-400-18-LT, C-steel
sealing material:	Nitrile (NBR) or Viton (FPM), other materials on request
installation position:	vertical
measuring connections:	G ¼
bleeder connections:	G ½

Classified under the Pressure Equipment Directive 2014/68/EU for mineral oil (fluid group 2), Article 4, Para. 3.
Classified under ATEX Directive 2014/34/EU according to specific application (see questionnaire sheet-no. 34279-4).

Pressure drop flow curves:

Filter calculation/sizing

The pressure drop of the assembly at a given flow rate Q is the sum of the housing Δp and the element Δp and is calculated as follows:

$$\Delta p_{assembly} = \Delta p_{housing} + \Delta p_{element}$$

$$\Delta p_{housing} = (\text{see } \Delta p = f(Q) \text{ - characteristics})$$

$$\Delta p_{Element} (mbar) = Q \left(\frac{l}{min} \right) \times \frac{MSK}{10} \left(\frac{mbar}{l/min} \right) \times v \left(\frac{mm^2}{s} \right) \times \frac{p}{0,876} \left(\frac{kg}{dm^3} \right)$$

For ease of calculation our Filter Selection tool is available online at
www.eatonpowersource.com/calculators/filtration/

Material gradient coefficients (MSK) for filter elements

The material gradient coefficients in mbar/(l/min) apply to mineral oil (HLP) with a density of 0,876 kg/dm³ and a kinematic viscosity of 30 mm²/s (139 SUS). The pressure drop changes proportionally to the change in kinematic viscosity and density.

HDD	VG				
	3VG	6VG	10VG	16VG	25VG
170	2,187	1,518	0,972	0,846	0,578
240	1,685	1,170	0,749	0,652	0,446
360	1,233	0,856	0,548	0,477	0,326
450	0,907	0,630	0,403	0,351	0,240

$\Delta p = f(Q)$ – characteristics according to ISO 3968

The pressure drop characteristics apply to mineral oil (HLP) with a density of 0,876 kg/dm³. The pressure drop changes proportionally to the density.

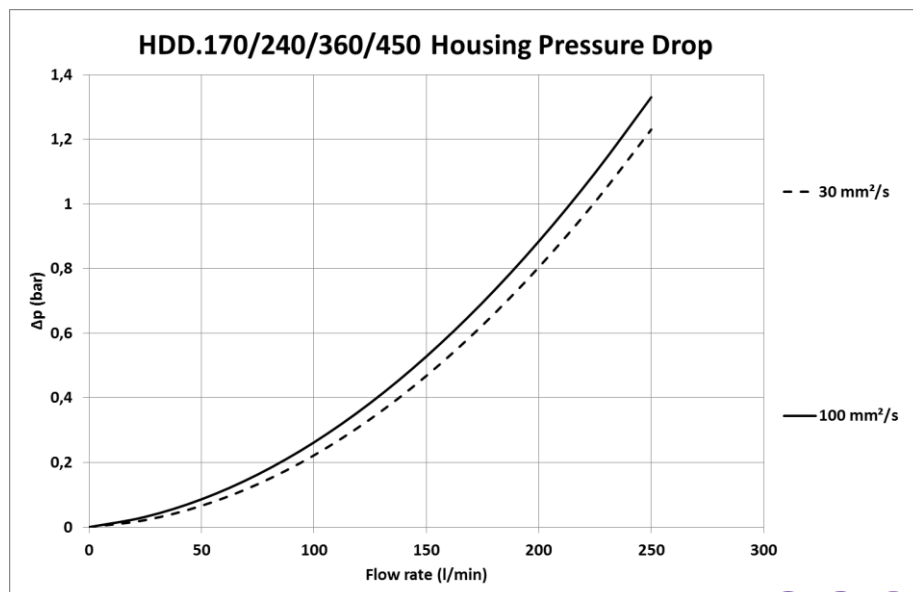

For more information:

WEB: FLTR.com.au PHONE: (+61) 1300 62 4020 EMAIL: info@FLTR.com.au SKYPE: Purple.Engineering

Symbols:

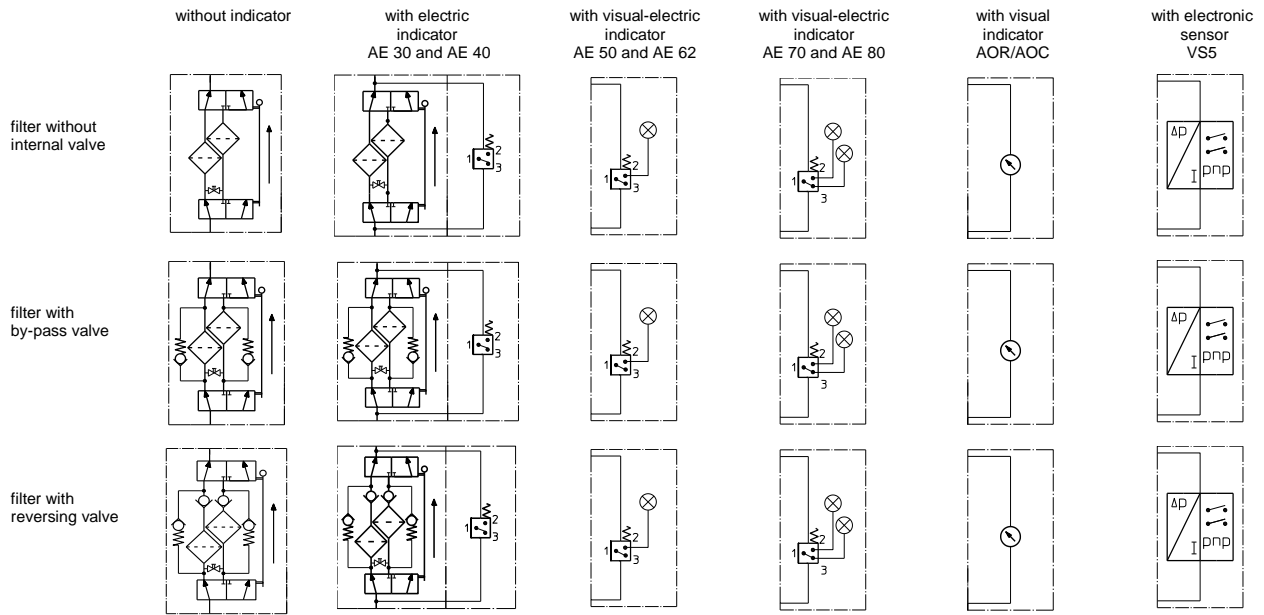

Spare parts:

item	qty.	designation	dimension				article-no.	
			HDD 170	HDD 240	HDD 360	HDD 450		
1	2	filter element	01E.170...	01E.240...	01E.360...	01E.450...		
2	2	O-ring	34 x 3,5				304338 (NBR)	304730 (FPM)
3	2	O-ring	75 x 3				302215 (NBR)	304729 (FPM)
4	2	support ring	81 x 2,6 x 1				304581	
5	2	O-ring	18 x 3				304359 (NBR)	304399 (FPM)
6	2	support ring	25 x 2,5 x 0,5				311311	
7	2	O-ring	56 x 3				305072 (NBR)	305322 (FPM)
8	2	screw plug	G ½				304678	
9	2	screw plug	G ¼				305003	
10	1	clogging indicator, visual	AOR or AOC				see sheet-no. 1606	
11	1	clogging indicator, visual-electric	AE				see sheet-no. 1615	
12	1	clogging sensor, electronic	VS5				see sheet-no. 1619	
13	1	screw plug	20913-4				309817	
14	1	pressure balance valve	DN10				305000	

item 13 execution only without clogging indicator or clogging sensor

Test methods:

Filter elements are tested according to the following ISO standards:

ISO 2941	Verification of collapse/burst resistance
ISO 2942	Verification of fabrication integrity
ISO 2943	Verification of material compatibility with fluids
ISO 3723	Method for end load test
ISO 3724	Verification of flow fatigue characteristics
ISO 3968	Evaluation of pressure drop versus flow characteristics
ISO 16889	Multi-pass method for evaluating filtration performance

For more information:

WEB: FLTR.com.au PHONE: (+61) 1300 62 4020 EMAIL: info@FLTR.com.au SKYPE: Purple.Engineering