

Series HP3.600-1350 DN50 PN420

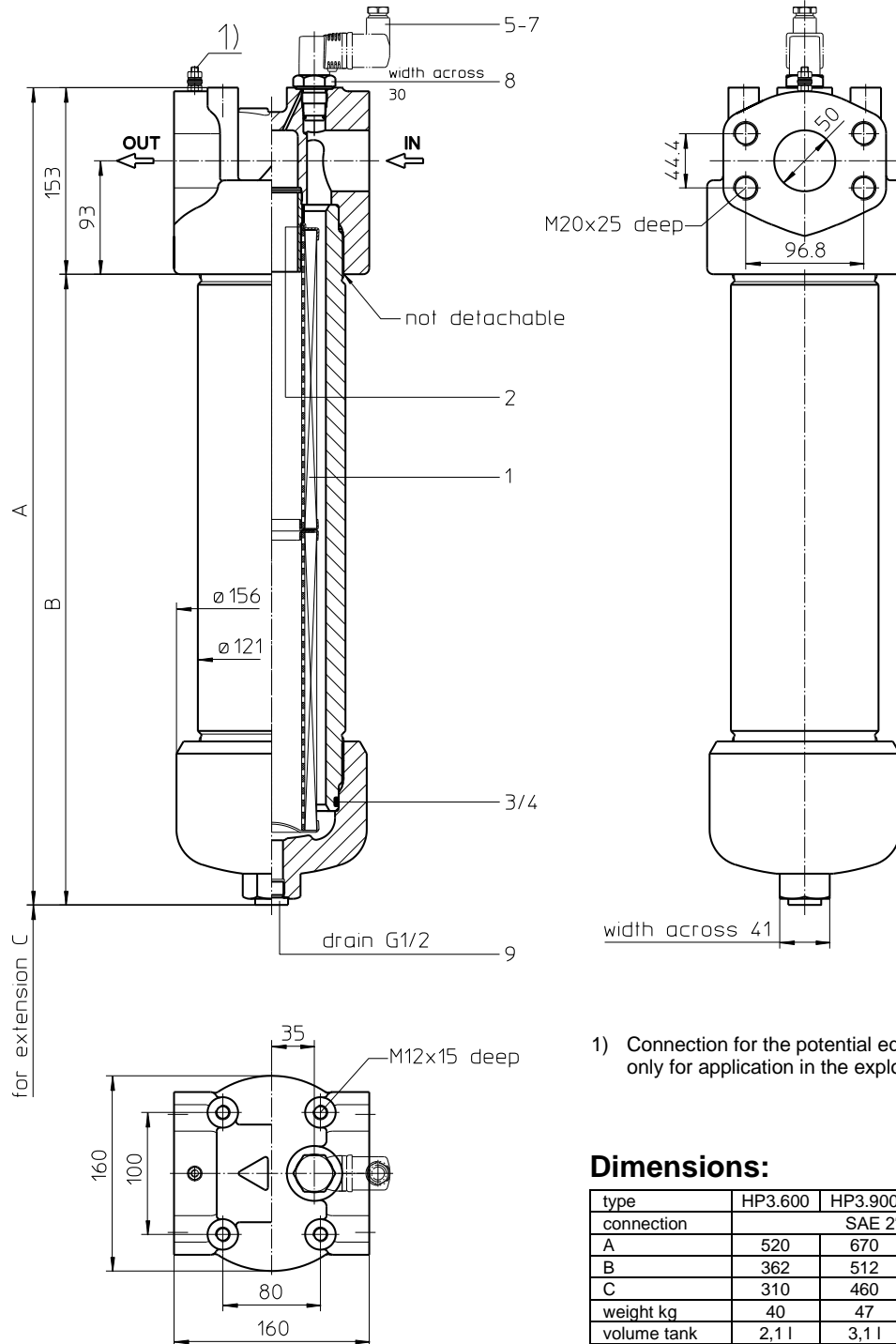

1) Connection for the potential equalization, only for application in the explosive area.

Dimensions:

type	HP3.600	HP3.900	HP3.1350
connection	SAE 2"		
A	520	670	918
B	362	512	760
C	310	460	710
weight kg	40	47	59
volume tank	2,1 l	3,1 l	4,6 l

Dimensions: mm

Designs and performance values are subject to change.

EDV 12/20

For more information:

WEB: FLTR.com.au PHONE: (+61) 1300 62 4020 EMAIL: info@FLTR.com.au SKYPE: Purple.Engineering



Pressure Filter

Series HP3.600-1350

DN50 PN420

Description:

Pressure filter series HP3.600-1350 have a working pressure up to 420 bar. Pressure peaks can be absorbed with a sufficient safety margin. The HP3-filters are flange mounted to the hydraulic system.

The filter element consists of star-shaped, pleated filter material, which is supported on the inside by a perforated core tube and is bonded to the end caps with a high-quality adhesive. The flow direction is from outside to inside. Filter elements are available down to 5 $\mu\text{m}_{(c)}$. Finer filtration is available upon request.

For cleaning the stainless steel mesh element (see special leaflets 21070-4 and 39448-4) or changing the filter element, remove the pipe plug and take out the element. The mesh elements are not guaranteed to maintain 100% performance after cleaning.

Eaton filter elements are known for high intrinsic stability and an excellent filtration capability, a high dirt-retaining capacity and a long service life.

Eaton filter elements are available up to a pressure resistance of Δp 160 bar and a rupture strength of Δp 250 bar.

Eaton filter can be used for petroleum-based fluids, HW emulsions, water glycols, most synthetic fluids and lubrication fluids. Consult factory for specific fluid applications.

The internal valves are integrated into the centering pivot for the filter element. After reaching the opening pressure the by-pass valve causes that an unfiltered partial flow passes the filter.

The reversing valve provides another level of protection for the filter element. The reverse flow will not be filtered.

1. Type index:

1.1. Complete filter: (ordering example)

HP3. 900. 10VG. HR. E. P. - . FS. 8. - . - . AE

1	2	3	4	5	6	7	8	9	10	11	12
---	---	---	---	---	---	---	---	---	----	----	----

- 1 series**
HP3 = pressure filter
- 2 nominal size:** 600, 900, 1350
- 3 filter material:**
80G, 40G, 25G stainless steel wire mesh
25VG, 16VG, 10VG, 6VG, 3VG microglass
- 4 filter element collapse rating:**
30 = Δp 30 bar
HR = Δp 160 bar (rupture strength Δp 250 bar)
- 5 filter element design:**
E = single-end open
- 6 sealing material:**
P = Nitrile (NBR)
V = Viton (FPM)
- 7 filter element specification:**
- = standard
VA = stainless steel
IS06 = for HFC application, see sheet-no. 31601
- 8 process connection:**
FS = SAE-flange connection 6000 PSI
- 9 process connection size:**
8 = 2"
- 10 filter housing specification:**
- = standard
IS06 = for HFC application, see sheet-no. 31605
- 11 internal valve:**
- = without
S1 = with by-pass valve Δp 3,5 bar
S2 = with by-pass valve Δp 7,0 bar
R = with reversing valve, $Q \leq 465,348$ l/min
- 12 clogging indicator or clogging sensor:**
- = without
AOR = visual, see sheet-no. 1606
AOC = visual, see sheet-no. 1606
AE = visual-electric, see sheet-no. 1615
VS5 = electronic, see sheet-no. 1619

To add an indicator/sensor to your filter, use the corresponding indicator data sheet to find the indicator details and add them to the filter assembly model code.

1.2. Filter element: (ordering example)

01E. 900. 10VG. HR. E. P. -

1	2	3	4	5	6	7
---	---	---	---	---	---	---

- 1 series:**
01E. = filter element according to company standard
- 2 nominal size:** 600, 900, 1350
- 3 - 7** see type index-complete filter

Technical data:

operating temperature:	-10°C to +100°C
operating medium:	mineral oil, other media on request
max. operating pressure:	420 bar
test pressure:	600 bar
process connection:	SAE-flange 6000 PSI
housing material:	EN-GJS-400-18-LT, C-steel (filter pipe/plug)
sealing material:	Nitrile (NBR) or Viton (FPM), other materials on request
installation position:	vertical

Classified under the Pressure Equipment Directive 2014/68/EU for mineral oil (fluid group 2), Article 4, Para. 3.
 Classified under ATEX Directive 2014/34/EU according to specific application (see questionnaire sheet-no. 34279-4).

Pressure drop flow curves:

Filter calculation/sizing

The pressure drop of the assembly at a given flow rate Q is the sum of the housing Δp and the element Δp and is calculated as follows:

$$\Delta p_{assembly} = \Delta p_{housing} + \Delta p_{element}$$

$$\Delta p_{housing} = (\text{see } \Delta p = f(Q) \text{ - characteristics})$$

$$\Delta p_{Element} (mbar) = Q \left(\frac{l}{min} \right) \times \frac{MSK}{10} \left(\frac{mbar}{l/min} \right) \times v \left(\frac{mm^2}{s} \right) \times \frac{p}{0,876} \left(\frac{kg}{dm^3} \right)$$

For ease of calculation our Filter Selection tool is available online at

www.eatonpowersource.com/calculators/filtration/

Material gradient coefficients (MSK) for filter elements

The material gradient coefficients in mbar/(l/min) apply to mineral oil (HLP) with a density of 0,876 kg/dm³ and a kinematic viscosity of 30 mm²/s (139 SUS). The pressure drop changes proportionally to the change in kinematic viscosity and density.

HP3	VG					G		
	3VG	6VG	10VG	16VG	25VG	25G	40G	80G
600	0,776	0,539	0,345	0,300	0,205	0,0247	0,0231	0,0158
900	0,538	0,374	0,239	0,208	0,142	0,0155	0,0144	0,0099
1350	0,336	0,233	0,149	0,130	0,089	0,0100	0,0093	0,0064

$\Delta p = f(Q)$ – characteristics according to ISO 3968

The pressure drop characteristics apply to mineral oil (HLP) with a density of 0,876 kg/dm³. The pressure drop changes proportionally to the density.

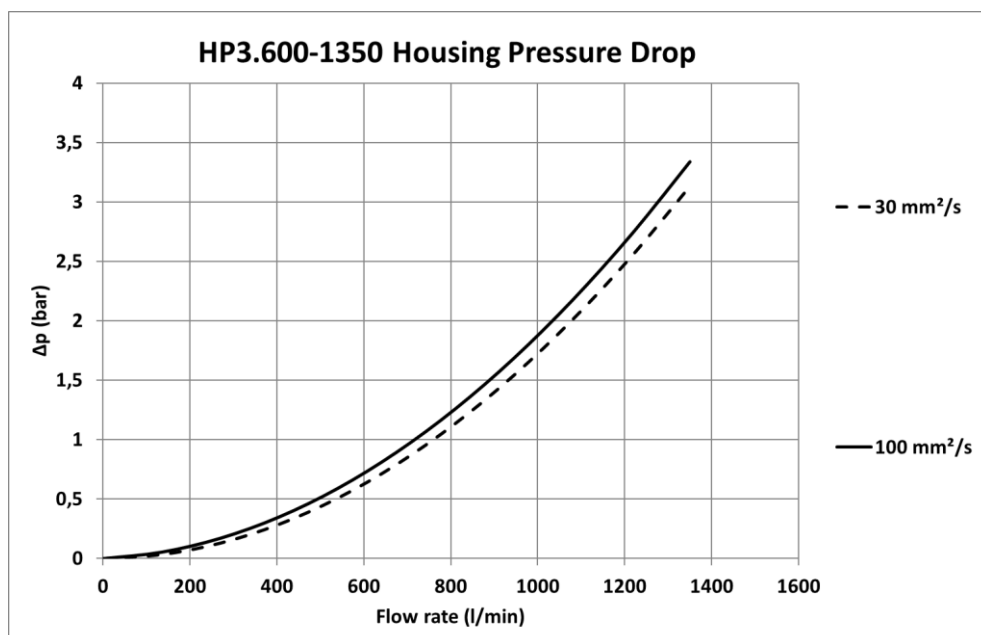

For more information:

WEB: FLTR.com.au PHONE: (+61) 1300 62 4020 EMAIL: info@FLTR.com.au SKYPE: Purple.Engineering

Symbols:

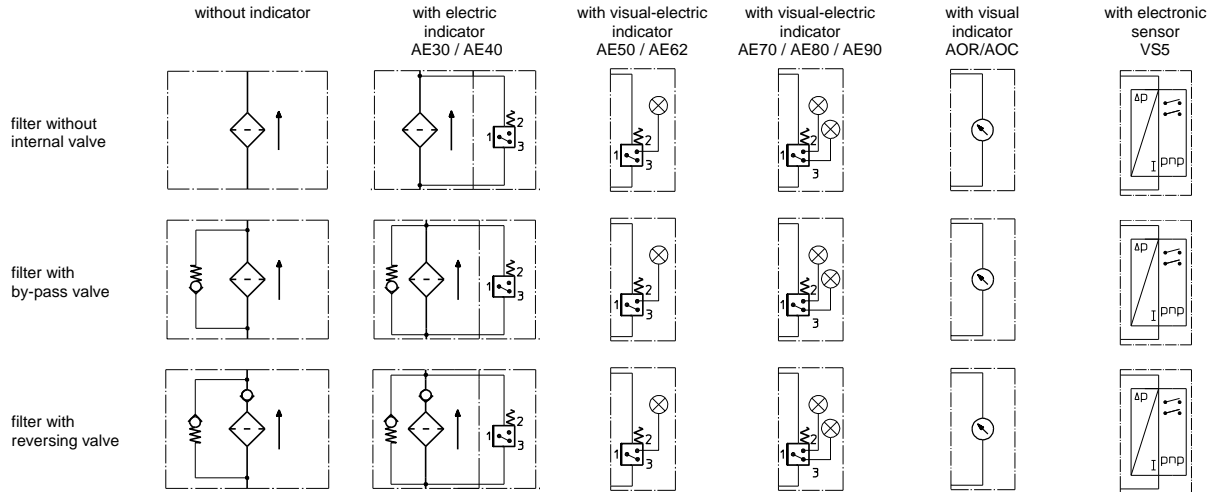

Spare parts:

item	qty.	designation	dimension			article-no.	
			HP3.600	HP3.900	HP3.1350		
1	1	filter element	01E.600...	01E.900...	01E.1350...		
2	1	O-ring	48 x 3			304357 (NBR)	304404 (FPM)
3	1	O-ring	98 x 4			301914 (NBR)	304765 (FPM)
4	1	support ring	110 x 3,5 x 2			304802	
5	1	clogging indicator visual	AOR or AOC			see sheet-no. 1606	
6	1	clogging indicator visual-electric	AE			see sheet-no. 1615	
7	1	clogging sensor electronic	VS5			see sheet-no. 1619	
8	1	screw plug	20913-4			309817	
9	1	screw plug	G ½			304678	

item 8 execution only without clogging indicator or clogging sensor

Test methods:

Filter elements are tested according to the following ISO standards:

ISO 2941	Verification of collapse/burst resistance
ISO 2942	Verification of fabrication integrity
ISO 2943	Verification of material compatibility with fluids
ISO 3723	Method for end load test
ISO 3724	Verification of flow fatigue characteristics
ISO 3968	Evaluation of pressure drop versus flow characteristics
ISO 16889	Multi-pass method for evaluating filtration performance

For more information:

WEB: FLTR.com.au PHONE: (+61) 1300 62 4020 EMAIL: info@FLTR.com.au SKYPE: Purple.Engineering