

# PRESSURE FILTER, manifold mounted

Series HPF 30, HPFO 30 DN 10 PN 315

Sheet No.  
**1495 C**

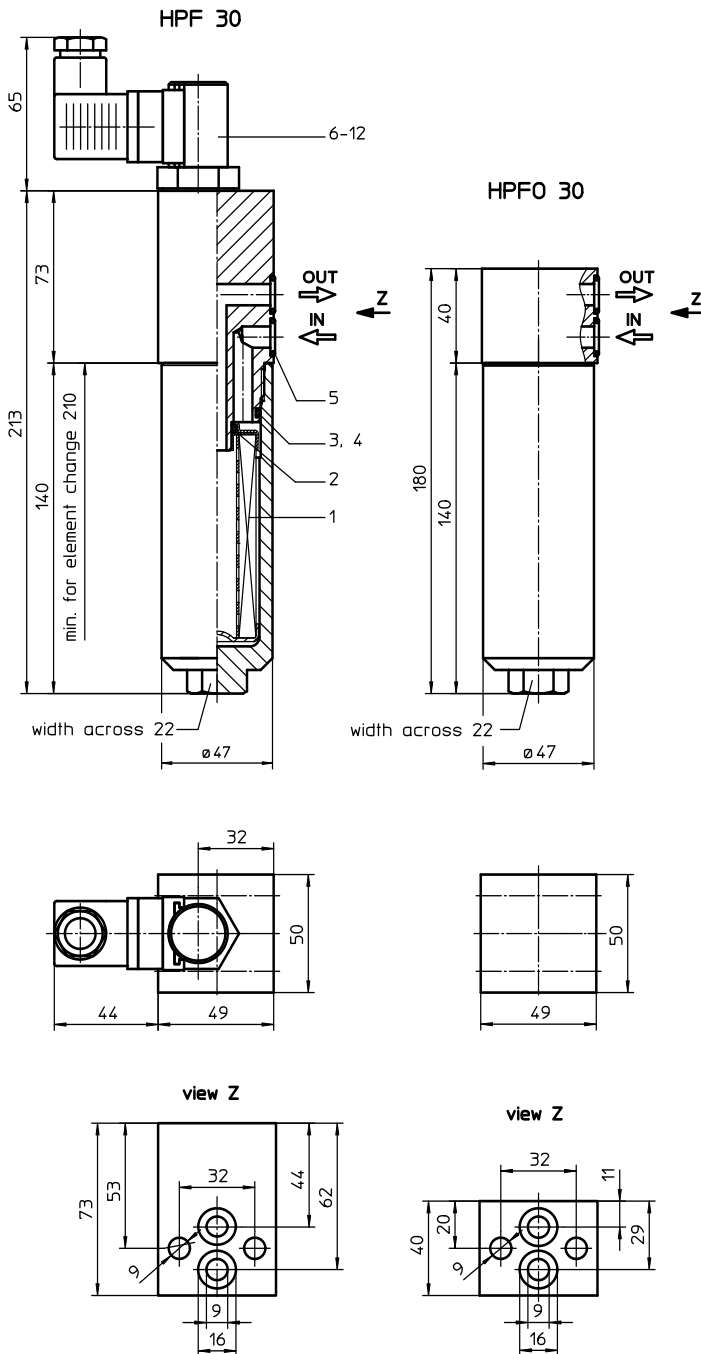

## 1. Type index:

### 1.1. Complete filter: (ordering example)

**HPF.30.10VG.HR.E.P.-.F.2.-.AE**

1	2	3	4	5	6	7	8	9	10	11
---	---	---	---	---	---	---	---	---	----	----

- 1 **series:**  
 HPF = medium pressure filter, manifold mounted with indicator  
 HPFO = medium pressure filter, manifold mounted without indicator
- 2 **nominal size:** 30
- 3 **filter-material and filter-fineness:**  
 80 G = 80  $\mu\text{m}$ , 40 G = 40  $\mu\text{m}$ , 25 G = 25  $\mu\text{m}$   
 stainless steel wire mesh  
 25 VG = 20  $\mu\text{m}_{(c)}$ , 16 VG = 15  $\mu\text{m}_{(c)}$ , 10 VG = 10  $\mu\text{m}_{(c)}$ ,  
 6 VG = 7  $\mu\text{m}_{(c)}$ , 3 VG = 5  $\mu\text{m}_{(c)}$  Interpor fleece (glass fibre)
- 4 **resistance of pressure difference for filter element:**  
 30 =  $\Delta p$  30 bar  
 HR =  $\Delta p$  160 bar (rupture strenght  $\Delta p$  250 bar)
- 5 **filter element design:**  
 E = single-end open
- 6 **sealing material:**  
 P = Nitrile (NBR)  
 V = Viton (FPM)
- 7 **filter element specification:** (see catalog)  
 - = standard  
 VA = stainless steel  
 IS06 = see sheet-no. 31601
- 8 **connection:**  
 F = manifold mounted
- 9 **connection size:**  
 2 = DN 10
- 10 **filter housing specification:** (see catalog)  
 - = standard  
 IS06 = see sheet-no. 31605
- 11 **clogging indicator or clogging sensor:**  
 series HPFO:  
 - = without  
 series HPF:  
 AOR = visual, see sheet-no. 1606  
 AOC = visual, see sheet-no. 1606  
 AE = visual-electrical, see sheet-no. 1615  
 VS1 = electrical, see sheet-no. 1617  
 VS2 = electrical, see sheet-no. 1618

### 1.2. Filter element: (ordering example)

**01E.30.10VG.HR.E.P.-**

1	2	3	4	5	6	7
---	---	---	---	---	---	---

- 1 **series:**  
 01E. = filter element according to company standard
- 2 **nominal size:** 30
- 3 - 7 see type index-complete filter

weight without indicator: approx. 1,8 kg  
 weight with indicator : approx. 2,4 kg

## 2. Spare parts:

item	qty.	designation	dimensions	article-no.	
1	1	filter element	01E. 30		
2	1	O-ring	11 x 3	312603 (NBR)	312727 (FPM)
3	1	O-ring	32 x 2,5	306843 (NBR)	308268 (FPM)
4	1	support ring	37 x 2,1 x 1	305466	
5	2	O-ring	12 x 2	311014 (NBR)	310271 (FPM)
6	1	clogging indicator, visual	AOR or AOC	see sheet-no. 1606	
7	1	clogging indicator, visual-electrical	AE	see sheet-no. 1615	
8	1	clogging sensor, electrical	VS1	see sheet-no. 1617	
9	1	clogging sensor, electrical	VS2	see sheet-no. 1618	
10	1	O-ring	15 x 1,5	315357 (NBR)	315427 (FPM)
11	1	O-ring	22 x 2	304708 (NBR)	304721 (FPM)
12	1	O-ring	14 x 2	304342 (NBR)	304722 (FPM)

## 3. Description:

Pressure filter of the series HPF 30 and HPFO 30 are suitable for a working pressure up to 315 bar.

The pressure peaks are absorbed by a sufficient margin of safety. The filters are flange mounted to the hydraulic system.

The filter element consists of star-shaped, pleated filter material which is supported on the inside by a perforated core tube and is bonded to the end caps with a high-quality adhesive. The flow direction is from outside to inside.

Filter elements are available down to 4  $\mu\text{m}_{\text{e}}$ .

Internormen Product Line filter elements are known as elements with a high intrinsic stability and an excellent filtration capability, a high dirt-retaining capacity and a long service life.

Internormen Product Line filter are suitable for all petroleum based fluids, HW-emulsions, most synthetic hydraulic fluids and lubrication oils.

Internormen Product Line filter elements are available up to a pressure difference resistance of  $\Delta p$  160 bar and a rupture strength of  $\Delta p$  250 bar.

## 4. Technical data:

temperature range:	-10°C to + 80°C (for a short time + 100°C)
operating medium:	mineral oil, other media on request
max. operating pressure:	315 bar
test pressure:	450 bar
connection system:	manifold mounted
housing material:	C-steel
sealing material:	Nitrile (NBR) or Viton (FPM), other materials on request
installation position:	vertical
volume tank:	0,1 l

Classified under the Pressure Equipment Directive 97/23/EC for mineral oil (fluid group 2), Article 3, Para. 3.

Classified under ATEX Directive 94/9/EC according to specific application (see questionnaire sheet-no. 34279-4).

## 5. Symbols:

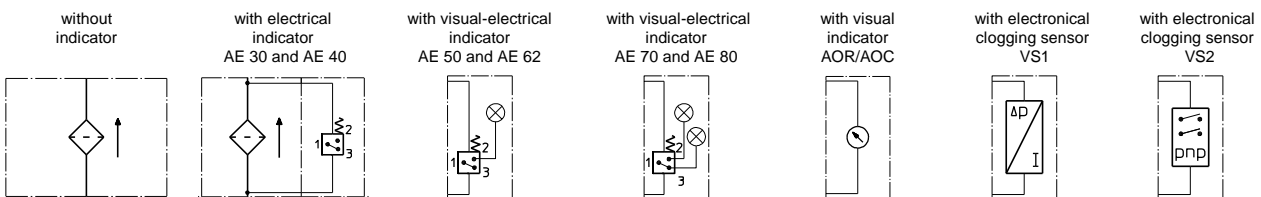

## 6. Pressure drop flow curves:

Precise flow rates see 'Interactive Product Specifier', respectively  $\Delta p$ -curves - depending on filter fineness and viscosity.

## 7. Test methods:

Filter elements are tested according to the following ISO standards:

- ISO 2941 Verification of collapse/burst resistance
- ISO 2942 Verification of fabrication integrity
- ISO 2943 Verification of material compatibility with fluids
- ISO 3723 Method for end load test
- ISO 3724 Verification of flow fatigue characteristics
- ISO 3968 Evaluation of pressure drop versus flow characteristics
- ISO 16889 Multi-pass method for evaluating filtration performance

E 1495 C