

Series IFPM 33

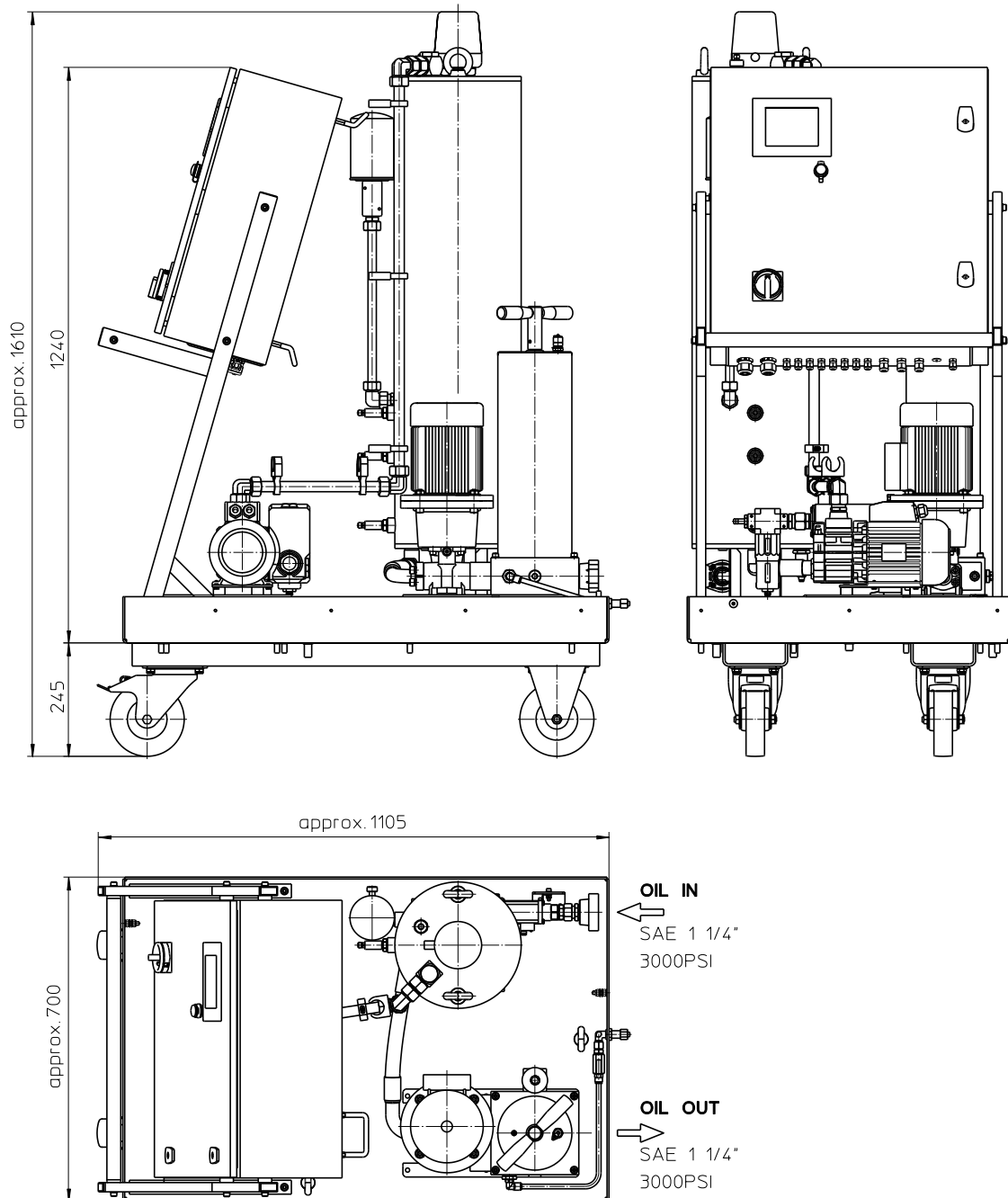

Weight: approx. 238 kg

Dimensions: mm

Designs and performance values are subject to change.

EDV 10/20

For more information:

WEB: FLTR.com.au PHONE: (+61) 1300 62 4020 EMAIL: info@FLTR.com.au SKYPE: Purple.Engineering



Fluid Purifier System

Series IFPM 33

Description:

The filter system of the series IFPM33 is intended for dewatering, filtration and degassing of hydraulic and lubricating fluids in the offline circuit. The functional principle is the vacuum dewatering. So it is possible to remove free water as well as dissolved water.

Water is one of the most common contaminants and the second most destructive besides particulate contamination. Some of the most damaging problems water contamination can cause are:

- Fluid breakdown
 - Additive depletion
 - Reduction of the lubrication properties of the fluid
 - Oil oxidation
- Internal corrosion
- Abrasive wear in system components
- Reduced dielectric strength

Operating principle:

The contaminated fluid is drawn into the Fluid Purifier System by a vacuum. After a solenoid valve, the fluid passes a heater and then enters the vacuum chamber. At the same time, ambient air, which is sucked in through a fine filter and a throttle valve, flows against the oil in the vacuum chamber. In the vacuum chamber, a large free surface is created by packing material and the water is absorbed by the air. Through an oil mist separator the humid air is released to the atmosphere with a vacuum pump. The fluid is pumped back into the oil reservoir by a gear pump through a high efficiency fine filter.

The contamination level of the filter element is measured continuously with the clogging sensor VS5. When the filter element is contaminated, the filter system is automatically switched off. The filter element can be changed without tools. For protection against overpressure, the gear pump is equipped with a safety valve.

The filter system is controlled by a coloured 5,7" Touch display. After start it works fully automatically. As standard, the display has an Ethernet connection and a web server for remote control.

The standard installed water sensor allows a permanent control of the water saturation of the fluid.

Type index:

Fluid Purifier System: (ordering example)

IFPM.	33.	10VG.	10.	B.	V.	-.
1	2	3	4	5	6	7
P114.	D05.	VP01.	VS5.	-.	A	
8	9	10	11	12	13	

- 1 series:**
IFPM = Fluid Purifier System, mobile
- 2 nominal size:** 33
- 3 filter material:**
25VG, 16VG, 10VG, 6VG, 3VG, 1VG microglass
- 4 filter element collapse rating:**
10 = Δp 10 bar (1000 kPa)
- 5 filter element design:**
B = both sides open
- 6 sealing material:**
V = Viton (FPM)
- 7 filter element specification:**
- = standard
VA = stainless steel
- 8 pump unit:**
P114 = pump unit 114, NG 30.20
- 9 motor:**
D05 = rotary current motor 05:
50 Hz: 0,75 kW, 3-phase, 220...240/380...415V
60 Hz: 0,90 kW, 3-phase, 250...280/440...480V
- 10 vacuum pump:**
VP01 = vacuum pump 01:
50 Hz: 0,55 kW, 3-phase, 220...240/380...415V
60 Hz: 0,55 kW, 3-phase, 250...280/440...480V
- 11 clogging sensor:**
VS5 = VS5.1,5.V.-.NO.-.B.-, electric,
at p1 and p2, 1,5 bar (150 kPa), see sheet no. 1641
- 12 cover:**
- = without
I = Inclusive cover
- 13 supply voltage:**
A = 380V-415V; 50/60 Hz; 3Ph + PE
(delivery with 16A CEE plug for 3-phase current)
B = 440V-480V; 60 Hz; 3Ph + PE
X = other voltage on request

Filter element: (ordering example)

01NR.	630.	6VG.	10.	B.	V.	-
1	2	3	4	5	6	7

- 1 series:**
01NR = standard-return-line filter element according to DIN 24550, T4
- 2 nominal size:** 630
- 3 - 7** see type index- Fluid Purifier Systems

For more information:

WEB: FLTR.com.au PHONE: (+61) 1300 62 4020 EMAIL: info@FLTR.com.au SKYPE: Purple.Engineering



Technical data:

inlet connection:	1 ¼" SAE-flange 3000 PSI
outlet connection:	1 ¼" SAE-flange 3000 PSI
pump flow rate:*	29,1 l/min (50 Hz) / 34,9 l/min (60 Hz)
operating vacuum:	-0,6 bar (-60 kPa)
heater power:	supply voltage A: 3000 Watt/400V supply voltage B: 3000 Watt/460V
filter type:	NF 631
seal material:	Viton (FPM)
viscosity:	12...700 mm ² /s
dewatering rate:**	22 l/day
protection class:	IP54
ambient temperature:	0°C to +40°C
fluid temperature:	10°C to +80°C
external protection:	16 A

* Flow rate of the gear pump at a viscosity of the fluid of 32 mm²/s.

** Dewatering rate of free water, at a hydraulic oil of the viscosity class ISO VG32 and a fluid temperature of 60°C.

Test methods:

Filter elements are tested according to the following ISO standards:

ISO 2941	Verification of collapse/burst resistance
ISO 2942	Verification of fabrication integrity
ISO 2943	Verification of material compatibility with fluids
ISO 3723	Method for end load test
ISO 3724	Verification of flow fatigue characteristics
ISO 3968	Evaluation of pressure drop versus flow characteristics
ISO 16889	Multi-pass method for evaluating filtration performance

Note: Spare parts see IFPM33 maintenance manual.

For more information:

WEB: FLTR.com.au PHONE: (+61) 1300 62 4020 EMAIL: info@FLTR.com.au SKYPE: Purple.Engineering

