

CCM 01 - Set

Contamination Control Monitor



Instruction manual

Version 2.7

Serial no. CCM 01:

Serial no. PFS 01:

Version valid from: 22.08.2016

For more information:

WEB: FLTR.com.au PHONE: (+61) 1300 62 4020 EMAIL: info@FLTR.com.au SKYPE: Purple.Engineering

Index

	Seite
1. SAFETY INFORMATION	4
1.1. Dangers of maloperation	4
1.2. Intended applications	4
2. OPERATION AND INSTALLATION	5
2.1. Setup.....	5
2.1.1. Block diagram.....	5
2.2. General information	6
2.3. Measuring principle of the PFS 01 (Particle Flow Sensor)	6
2.4. Sensor installation	7
2.5. Optimum operating conditions	7
2.6. Installation of the display unit CCM 01	7
2.7. Electrical connection of the PFS 01 and the CCM 01	7
2.8. Operating the CCM 01 software	10
2.8.1. Control keys.....	10
2.8.2. Menu structure.....	11
2.8.3. Main menu.....	12
2.8.3.1. Measure	12
2.8.3.1.1. Viscosity Range.....	12
2.8.3.1.2. Report Format (ISO 4406 or NAS 1638)	12
2.8.3.1.3. Start.....	13
2.8.3.1.4. Storage Interval	13
2.8.3.2. Data Manager	14
2.8.3.2.1. Transfer Data	14
2.8.3.2.1.1. Data transfer by using the RS232 - interface.....	14
2.8.3.2.1.2. Data transfer by using the external printer.....	15
2.8.3.2.2. Delete Data	15
2.8.3.2.3. Stored Data	15
2.8.3.3. Options	15
2.8.3.3.1. Limits.....	16
2.8.3.3.2. Set Time	17
2.8.3.3.3. Calibration	17
2.8.3.3.4. CAN.....	18
3. DATA TRANSFER	18
3.1. Connection to an external computer as an evaluation device	19
3.1.1. Connection via RS232 – interface.....	19
3.1.2. Connection of the RS232 – adaptor plug into the interface	19
3.1.3. Connection of the Bluetooth modul EBT 01	19
3.2. Continuous data transfer of the actual measurements	19
3.2.1. HyperTerminal	19
3.2.2. Setup of HyperTerminal.....	20
3.2.3. Procedure.....	21
3.2.4. Protocol for the contiuous data transfer	21
3.3. Data transfer of the saved measurements	22
3.3.1. Export and evaluation of the stored data via “CCM 01 data manager Vers. 2.0”.....	22
3.3.2. One-time program installation.....	22
3.3.3. Procedure.....	23
4. EVALUATING MEASUREMENTS	28
5. CAN INTERFACE	29

5.1.	Introduction to CAN and CANopen	29
5.1.1.	CAN-Bus	29
5.1.2.	CANopen.....	29
5.2.	CANopen – functionality	30
5.3.	Start-up	30
5.3.1.	Baudrate.....	31
5.3.2.	Node ID	31
5.3.3.	Start.....	32
5.4.	Object dictionary	32
5.4.1.	Communication specific part.....	33
5.4.1.1.	Error register (Index 1001h)	33
5.4.1.2.	Manufacturer status register (Index 1002h)	33
5.4.2.	Manufacturer specific part.....	34
5.4.2.1.	Threshold settings.....	35
5.4.2.2.	Report format	35
5.4.2.3.	Viscosity range.....	35
5.4.2.4.	Sending measurement results.....	35
5.4.2.5.	Storage interval.....	35
5.4.2.6.	Stored data	35
5.4.2.7.	Process values.....	36
5.5.	SDO (Service Data Object)	36
5.6.	Transmit PDO	37
5.7.	Emergency Messages	37
5.8.	Guarding	37
5.8.1.	Nodeguarding.....	37
5.8.2.	Heartbeat.....	37
5.9.	Timestamp	38
5.10.	Network Management	38
5.11.	EDS-file	38
5.12.	Examples for CAN-communication	38
6.	<u>SENSOR CALIBRATION</u>	38
7.	<u>APPENDIX</u>	40
7.1.	Technical Data	40
7.1.1.	Laser sensor.....	40
7.1.2.	CCM 01 – Display unit	40
7.1.3.	CCM 01 – housing.....	41
7.1.3.1.	CCM 01 - backside of housing	41
7.2.	Pin assignment	42
7.2.1.	Laser sensor.....	42
7.2.2.	CCM 01 – display unit.....	42
7.2.2.1.	RS 232 interface and CAN – option	42
7.2.2.2.	Sensor connections – X11	43
7.2.2.3.	Power supply – 24 V DC	43
7.3.	Pressure difference characteristics	44
7.4.	Cleanliness classes according to ISO 4406:99	45
7.5.	Cleanliness classes according to NAS 1638	46
7.6.	Application areas - Compatibility	47
7.7.	Trouble shooting	47
7.8.	Shipment	47

1. Safety information

1.1. Dangers of maloperation

The **CCM 01** underwent a safety inspection according to IEC 1010-1/ EN 61010 – 1, part 1. Integrated hydraulic and electronic safety elements ensure safe operation if the device is used as it was intended.

In case of maloperation or abuse, as well as in case of insensitivity for application limits and safety regulations, the following threats can occur for:

- Life or physical condition of the operator,
- the **CCM 01**, as well as connected machines and systems connected,
- the accuracy of measurements of the **CCM 01**,
- the environment.

This manual does contain information and safety advice, which ensure risk free operations and which help to keep the device in an ideal condition.

Therefore, it is necessary that everybody having to do with the operation and maintenance of the unit strictly follows this instruction manual.

1.2. Intended applications

The **CCM 01 – Set** is an efficient and robust inline diagnostic measuring system for determining the contamination classes according to ISO 4406:99 and NAS 1638.

It works very reliably and does fulfil all requirements of daily measurements.

The set is intended and tested to operate with all usual hydraulic and gear fluids as well as synthetic esters.

Application limits:

Maximum acceptable operating pressure:	50 bar	/ 725 psi
Maximum oil temperature:	70 °C	/ 158 °F
Viscosity range:	10...400 mm ² /s	/ 46... 1854 SUS
Minimum volume flow:	500 ml/ min	/ 0,132 gal/ min
Maximum acceptable volume flow:	50 l/min	/ 13 gal/min

Generally, the **CCM 01 – Set** has to be operated with 24 V DC (ripple: < 300 mV_{pp})!

2. Operation and installation

2.1. Setup

The CCM 01 – Set consists of the PFS 01 (Particle Flow rate Sensor), a cable to connect the sensor (l = 5 m) and the CCM 01 – display unit.



A PFS 01 belongs always to a specific CCM 01. The calibration values of the PFS 01 are stored always in the respective CCM 01!

2.1.1. Block diagram

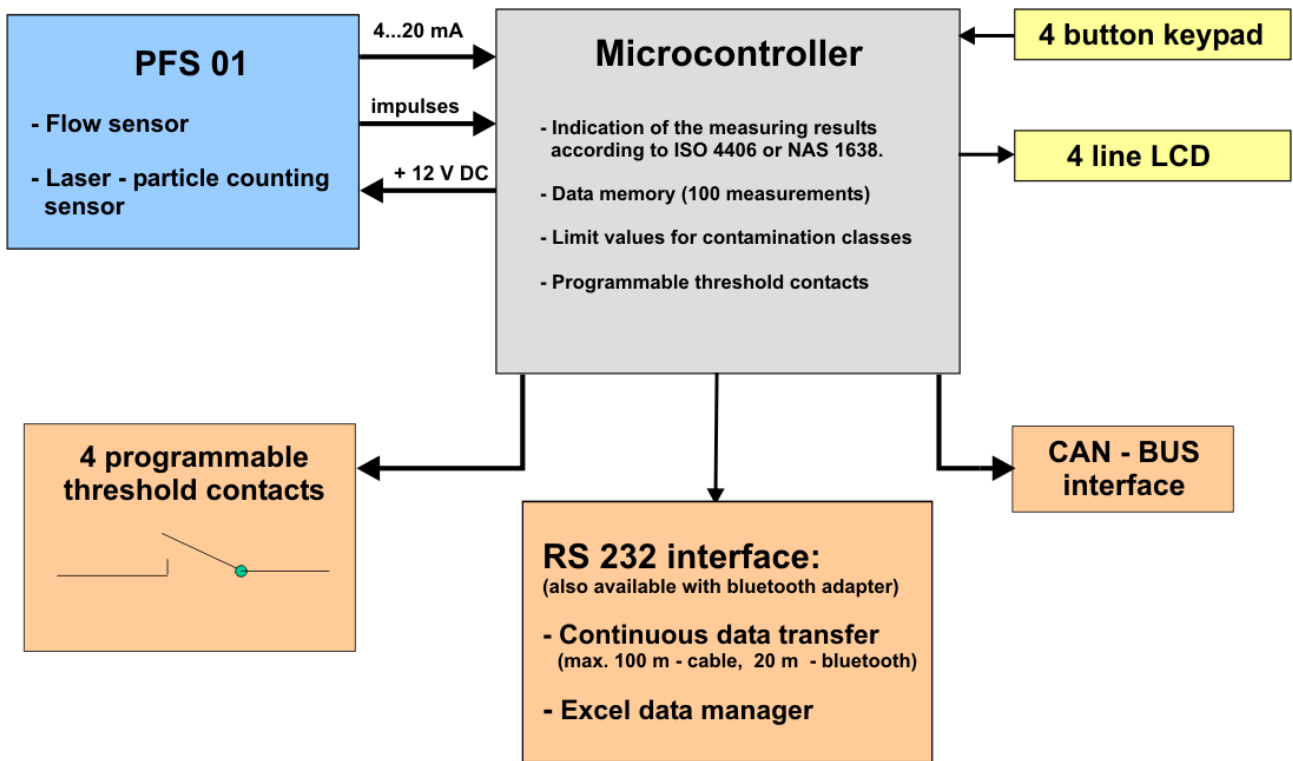

2.2. General information

The effects of contamination on hydraulic or lubricating systems are manifold. It causes significantly increased wear, increased risk of component failure as well as malfunctions.

The CCM 01 - set fulfils all necessary requirements for continuous monitoring and analysis of hydraulic systems and test stands. It is an inexpensive stationary monitoring solution.

The CCM 01 has the following functions:

- Automatic particle counting and display of the measuring results acc. to contamination classes ISO 4406 or NAS 1638 every 20 seconds.
- Storage of 100 measured data in selectable storage intervals.
- Transmission of the current measuring results via RS 232 interface.
- 4 programmable contamination limit values with 4 potential free relay contacts. When exceeding the limit value the appropriate relay contacts closes – thus allowing control functions in the hydraulic and lubrication system, which has to be observed.
- Transmission of the stored measured data on an external computer in a Windows Excel file.

The CCM 01 – Set should only be switched on when the PFS 01 is flown through with oil, because there is installed a thermic volume flow sensor. Very long running times without flow rate can cause damages!

2.3. Measuring principle of the PFS 01 (Particle Flow Sensor)

- The PFS 01 consists of two sensor elements:
Laser sensor for particle counting and flow sensor for measuring the volume flow in the measuring channel.
- The PFS 01 operates based on the offline flow principle:
Using a counter balance valve, a partial flow of the oil flowing through the device is lead through the flow sensor and the laser particle counting sensor in order to analyze.
- The counted particles per volume and the particle concentrations for these following particle sizes are determined: $> 4 \mu\text{m}_{(c)}$, $> 6 \mu\text{m}_{(c)}$, $> 14 \mu\text{m}_{(c)}$, $> 21 \mu\text{m}_{(c)}$ **or** $> 6,4 \mu\text{m}_{(c)}$, $> 14 \mu\text{m}_{(c)}$, $> 21 \mu\text{m}_{(c)}$, $> 37 \mu\text{m}_{(c)}$ (switchable). Results can be displayed according to ISO 4406 respectively NAS 1638.
- The sensor integrated in the PFS operates based on the light blockade principle and it is calibrated with ISO MDT according to ISO 11171.

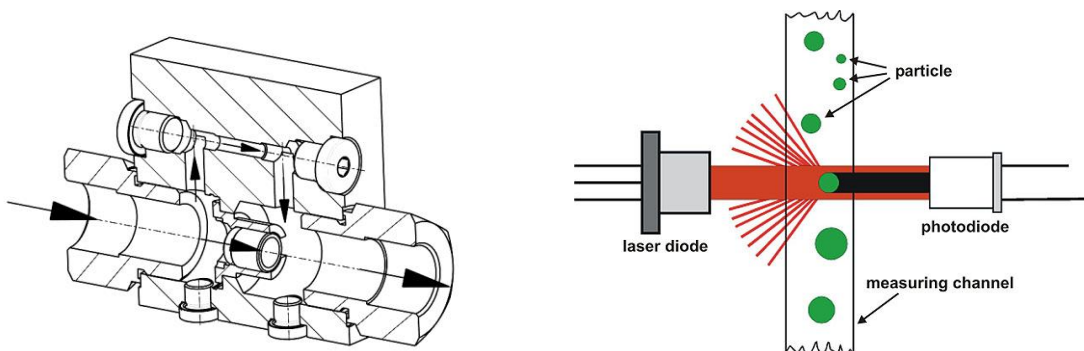

2.4. Sensor installation

- Integrate the PFS 01 in the hydraulic system (Connection: Thread according to ISO 228-G1 or $\frac{3}{4}$ ").
- The sensor should be installed and flow through vertically if possible. Optimal, from bottom to top to avoid air inclusions respectively to dissolve them fastly.
- The assembly should be vibration-cushioned and the connection should be made with hoses.
- The installation should not be directly on vibrated components or motors.

2.5. Optimum operating conditions

- If there are very fine air bubbles in the oil, there is the possibility that these air bubbles are counted as particles. With a measurement under pressure (40 bar), a suppression of air bubbles is reached.
- There is another variant of the PFS 01 sensor. With this variant only the measuring channel of the sensor is flown through. For this variant a constant volume flow of 30 – 100 ml/min must be provided.
- At very low viscosities (10 – 20 mm²/s) there should be installed a more weak spring in the bypass valve and the total volume flow through the sensor should not be higher than 20 l/min.

2.6. Installation of the display unit CCM 01

- Mount the CCM 01 display unit to the system. (see chapter 7.1.3.1)



2.7. Electrical connection of the PFS 01 and the CCM 01

- Connect the display unit with the sensor using the cable. Extend the sensor cable after consultation with the manufacturer only.
- Connect the 24 V power cable and the CCM 01 display unit.
 - Loose screws and remove cover.



Cable screws:
Cable diameter:

PG 9 **PG 11** **PG 13,5**
 4 – 8 mm 5 – 10 mm 6 – 12 mm

- Place the 24 V DC power cable through the screwed cable gland PG 9 or 13.5 (depending on cable size) and connect it (see chapter 7.2 or the list on the cover).



- Put the threshold transmission cable in the screwed cable gland PG 9 or PG 13.5 (depending on cable size) according to the pin assignment (see chapter 7.2 or the list on the cover).
- If threshold transmission is not necessary, close the unused screwed cable gland using the dummy plug in order to keep the IP-65 protection class.
- Connection 15: black/GND, optional depending on filter board in Sensor cable

- **The CCM 01 set is ready for operation, if the laser sensor, the power cable and the threshold transmission cable are connected to the CCM 01 display unit.**

2.8. Operating the CCM 01 software

- After the sensor has been entered into the hydraulic system, considering all application limits, start the CCM 01.
- Wait through the welcome screen until the main menu is being displayed. It can be operated using the control keys.

2.8.1. Control keys

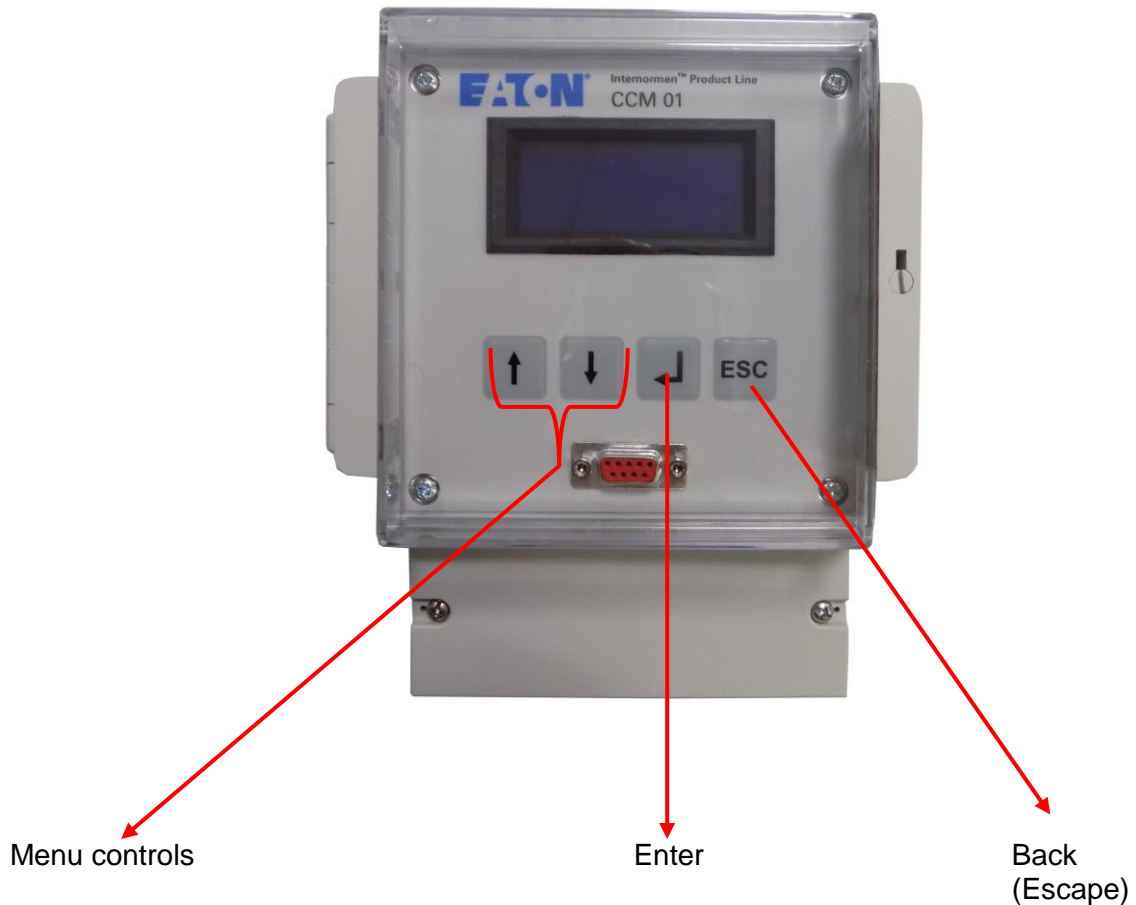

2.8.2. Menu structure

- The menu structure consists of three levels (plus start screen), the first both levels serve only navigation for the third level from which the single set options and measuring options can be started.
- The following structure diagram shows the composition of menu navigations.

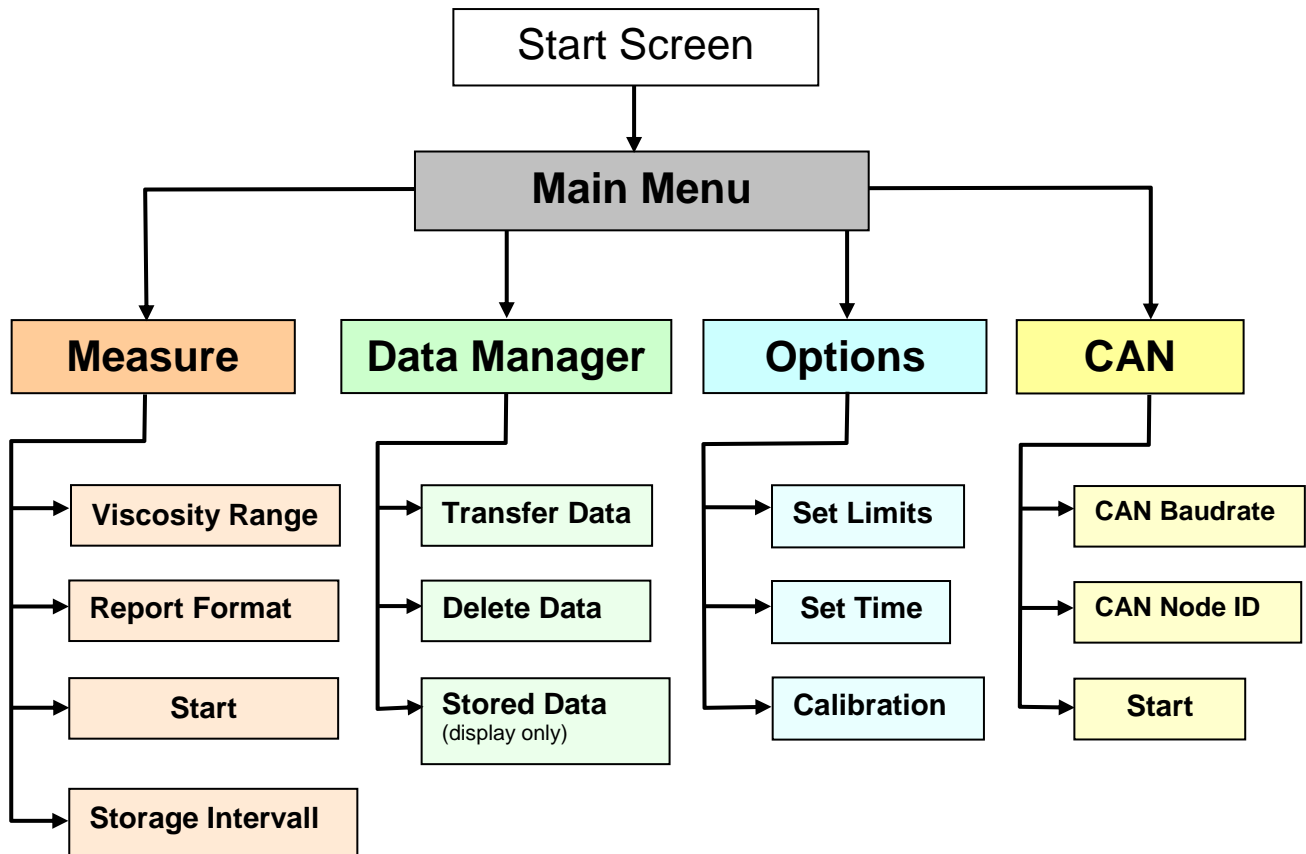

2.8.3. Main menu



- Choose a submenu with the [↑↓] buttons.
- The chosen item is marked with a * on the left side of the menu.
- Enter the chosen menu item by hitting the [↵] button.

2.8.3.1. Measure

Selection of the viscosity range, the using classification (ISO 4406 or NAS 1638) and start of the measuring.



- Choose a submenu with the [↑↓] buttons.
- The chosen item is marked with a * on the left side of the menu.
- Enter the chosen menu item by hitting the [↵] button.
- Use [ESC] to go back to the previous menu. (Display shows: ←)

2.8.3.1.1. Viscosity Range

Selection of the viscosity range from used fluid allowing for the fluid temperature.



- Use the [↑↓] buttons to choose the viscosity range.
- The selected menu item will be marked with a * on the left side.
- By hitting the [↵] button the selection of a viscosity range is confirmed.
- You will automatically jump to the [MEASURE] menu.

2.8.3.1.2. Report Format (ISO 4406 or NAS 1638)

Selection of the classification type (ISO 4406 or NAS 1638).

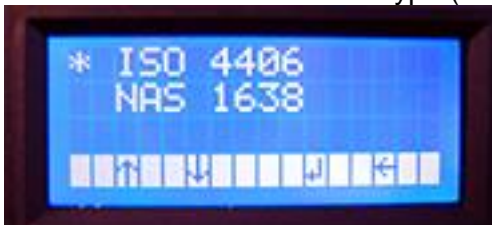

- Use the [↑↓] buttons to select a classification.
- The chosen classification is marked with a * on the left side of the menu.
- By hitting [↵] the classification type is adopted and you will jump to the [MEASURE] menu automatically.

2.8.3.1.3. Start

- Measurements are performed automatically and the results can be displayed as contamination classes. (depending upon selected classification type)
- During the measuring the particles per counting channel and the volume flow constantly put out via the RS232 interface. (see chapter 3.2)

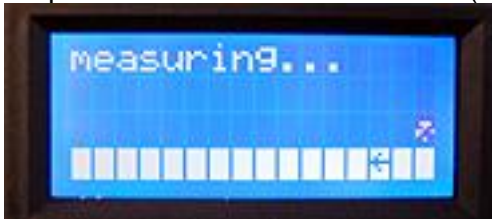

- Serially, the CCM 01 comes with the data manager software. This software edits and manages measurements stored by the CCM 01.
- For this application a storage interval has to be selected. (see chapter 2.8.3.1.4)
- Measurements will be stored continuously on the internal memory of the CCM 01 according to the selected storage interval. They can be transferred to an external computer using the RS232 interface or the Bluetooth modul EBT 01 in order to be edited and managed using the data manager software. (see chapter 3.3)



- Fixed limiting values are shown by a rectangle.
- Exceeded limiting values are shown by a filled out rectangle in the display.

NOTICE After disconnecting the power supply during the measurement it will automatically continue the measurement after reconnecting.

- Measurements will be performed until the operator hits [**ESC**] and switches back to the [**MEASURE**] menu.

2.8.3.1.4. Storage Interval

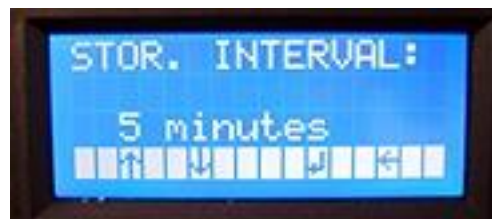

- Use the [**↑↓**] button to choose storage interval.
- The **intervals** that can be **chosen** are between **five minutes** and **seven days**. Storing the set interval will occur in a **battery backed RAM**. In case of a power outage, the **setting is saved**.
- **100 measurements** can be stored. After that, the oldest measurement is overwritten.
- Chose the storage interval with the [**↑↓**] buttons and confirm by hitting the [**↵**] button – automatic return to the [**MEASURE**]– menu.
- Use [**ESC**] to go back to the previous menu – changes will not be adopted.

2.8.3.2. Data Manager

This submenu serves for transferring and deleting of the saved measurements.



- Choose submenu with the [↑↓] buttons.
- The chosen item is marked with a * on the left side of the menu.
- Enter the chosen menu item by hitting the [↵] button.
- Use [ESC] to go back to the previous menu. (Display shows: ←)

2.8.3.2.1. Transfer Data

Data transfer of the stored measurements by using the RS232 interface or the external printer. (optional available at Eaton Technologies GmbH)

NOTICE It is necessary to use a special printer with RS232 interface. .



- Choose submenu with the [↑↓] buttons.
- The chosen item is marked with a * on the left side of the menu.
- Confirm by using the [↵] button.
⇒ **Start of the data transfer.**

2.8.3.2.1.1. Data transfer by using the RS232 - interface



- After selecting the menu point „RS232“ a **cyclic output of all saved measurements** takes place via the RS232 - interface.
- Every measurement is being transferred as a separate ASCII – streak.
- Transferring will be performed until the operator ends it by hitting [ESC].

2.8.3.2.1.2. Data transfer by using the external printer



CCM 01
Eaton Technologies GmbH
date: 16.12.2009
time: 10:46
contamination classes
according to ISO 4406/99:
>4µm/>6µm/>14µm date time
19/19/19 16.12.2009 10:40
19/19/19 16.12.2009 10:41
19/19/19 16.12.2009 10:41
contamination classes
according to NAS 1638:
5-15µm/15-25µm/25-50µm date time
11/00/12 16.12.2009 10:41
11/00/12 16.12.2009 10:42

- After selecting „Printer“ a singular report print out of all saved measurements takes place.
- **NOTICE** Follow the instruction manual of the external printer!
- Use [ESC] to go back to the previous menu.

2.8.3.2.2. Delete Data



- This option will **delete all data** from the measuring memory. It is irreversible. Therefore the deletion has to be confirmed with [YES].
- Use the [↑↓] buttons to select [YES] or [NO] and confirm by hitting [↵].
- Use [ESC] to go back to the previous menu.

2.8.3.2.3. Stored Data



- This is not a menu item that selects anything – **only the number of stored data is being displayed.**

2.8.3.3. Options



- Choose submenu with the [↑↓] buttons.
- The chosen item is marked with a * on the left side of the menu.
- Enter the chosen menu item by hitting the [↵] button.
- Use [ESC] to go back to the previous menu.

2.8.3.3.1. Limits

When achieving or exceeding the set limit values in the measuring cycle the corresponding threshold contacts switch or rather close.

- With the setting of zero values the functionality of the threshold contacts is switched off
⇒ no switching or rather closing of the threshold contacts.
- Threshold settings can be changed for each classification type and each counting channel.
- These settings will also be stored in the back-up RAM.



- Use the [↑↓] buttons to select the type of classification.
- The selected type will be marked with a * on the left side of the menu.
- Go to the selected classification type by hitting [↵].

Classification ISO 4406:99:

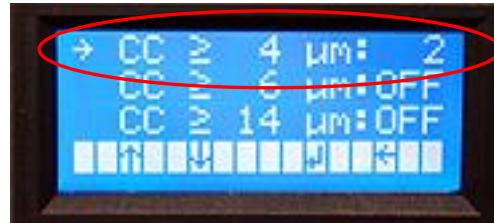

- Use the [↑↓] buttons to choose the counting channel that has to be changed and confirm by hitting [↵]. Use [↑↓] to set new contamination class threshold digit by digit and confirm with [↵].
- If new contamination class thresholds are set for all necessary counting channels use [**ESC**] to go back to the previous menu.

Classification NAS 1638:

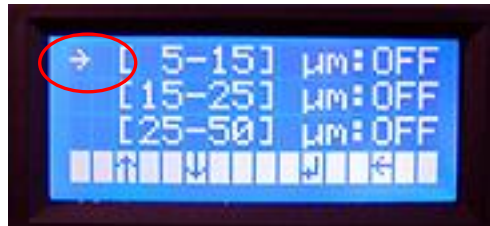

- Use the [↑↓] buttons to choose the counting channel that has to be changed and confirm by hitting [↵].

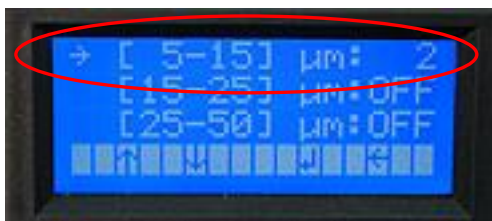

- Use [↑↓] to set new contamination class threshold digit by digit and confirm with [↵].

- If new contamination class thresholds are set for all necessary counting channels use [**ESC**] to go back to the previous menu.

2.8.3.3.2. Set Time



This function allows setting the real time clock that is integrated in the device.

NOTICE Due to the back-up battery, the clock will keep running even if the power supply is shut off.

- Day, month, year, hour and minute can be adjusted individually and they are being transmitted to the real time clock when the menu is being closed.



- Select the parameter that has to be changed using the [↑↓] buttons.
- The selected parameter is marked with a * on the left side of the menu.



- By hitting the [↵] button, the position that has to be changed can be switched and set a new parameter with the [↑↓] buttons.
- Use [ESC] to go back to the previous menu.

2.8.3.3.3. Calibration

As for all the other menus, every calibration value can be selected and changed individually. **NOTICE** Normally modifications are not necessary!

- Since calibration values are of fundamental importance for measurements and should not be lost, they are saved as EEPROM. Calibration values will even be saved if the back-up battery is dead. They do not have to be re-entered.



- Use the [↑↓] buttons to select the counting channel that is supposed to be changed.
- Confirm by hitting the [↵] button.
- The selected parameter will be marked with a * on the left side of the menu.

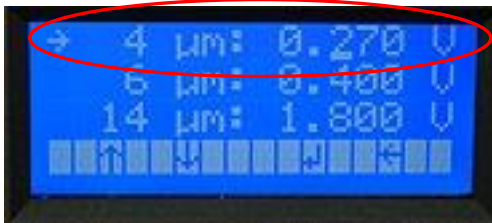

- Select the digit that shall be changed by hitting the [↵] button and use the [↑↓] buttons to set the new value.
- Confirm by hitting the [↵] button.
- Use [**ESC**] to go back to the previous menu.

The calibration values can be taken from the provided calibration certificate.

Calibration values :		noise signal:							160 mV
	4 μm _(e)	4,6 μm _(c) 2 μm	6 μm _(e)	6,4 μm _(c) 5 μm	10 μm _(c)	14 μm _(c) 15 μm	21 μm _(c) 25 μm	37 μm _(c) 50 μm	
Master sensor (particle)	67866	42563	17588	13588	2386	533	102	22	
Test sensor (particle)	68107	41974	17818	13824	2396	542	99	25	
admissible variation	≤ 2 %	≤ 2 %	≤ 2 %	≤ 2 %	≤ 2 %	≤ 2 %	*	*	
Test sensor threshold values (mV)	250	450	1050	1190	2680	4500	6950	9950	

2.8.3.3.4. CAN



- Choose submenu with the [↑↓] buttons.
- The chosen item is marked with a * on the left side of the menu.
- Enter the chosen menu item by hitting the [↵] button.
- Use [**ESC**] to go back to the previous menu.

Detail informations and instructions see chapter 5 CAN interface

3. Data transfer

- The data transfer from the CCM 01 to external computers is principle made by using the RS232 - interface. The data can be transferred with an interface cable as well as wirelessly with a Bluetooth modul.
- During the measuring the counted particles per channel ($\geq 4 \mu\text{m}_{(c)}$, $\geq 6 \mu\text{m}_{(c)}$, $\geq 14 \mu\text{m}_{(c)}$, $\geq 21 \mu\text{m}_{(c)}$ **or** $\geq 6,4 \mu\text{m}_{(c)}$, $\geq 14 \mu\text{m}_{(c)}$, $\geq 21 \mu\text{m}_{(c)}$, $\geq 37 \mu\text{m}_{(c)}$) and the volume flow are available. They will be displayed on the external computer with a terminal program such as HyperTerminals from Microsoft. With the help of the CCM 01 data manager the stored measurements can be read and exported into an Excel table.

3.1. Connection to an external computer as an evaluation device

3.1.1. Connection via RS232 – interface

- Connect the RS232 – connecting cable with the RS232 – interface on the frontplate



- Connect the other side of the RS232 – connecting cable with the computer.

3.1.2. Connection of the RS232 – adaptor plug into the interface

- Connect the adaptor with the connection SV 1 on the CCM 01 (the marked side of the ribbon cable should point to the case).
- Connect the other side of the adaptor cable with the SUB-D cable (9-pin, 1:1).

NOTICE In order to prevent damages on the CCM 01 or your computer, please make sure that you connect the adaptor plug the right way.



3.1.3. Connection of the Bluetooth modul EBT 01

- Bluetooth is an industrial standard according IEEE 802.15.1 for the wireless networking of devices over a short distance (outdoor up to 50 meter, depends on the adapter).
- The principal purpose is to replace the data cables between the devices.
- Put the Bluetooth modul EBT 01 in the port SV 1 of the CCM 01.



3.2. Continuous data transfer of the actual measurements

In this mode it is possible to transfer the actual measurement results from the CCM 01 to an external computer via RS232 or the Bluetooth modul EBT 01. (see chapter 3.1) The measurement results can be displayed on the computer using a communication program (for example: HyperTerminal from Microsoft windows)

3.2.1. HyperTerminal

- HyperTerminal is a communication program, beginning with version 2.0, that is provided with the windows system software.
- Establish a connection between the computer and the CCM 01 by using the HyperTerminal on the software side and by using the adaptor plug or the Bluetooth modul on the hardware side.

- The HyperTerminal isn't include in Windows Vista. It can be downloaded from the sides of Hilgraeve.

3.2.2. Setup of HyperTerminal

- One-time setup of HyperTerminal under:
START / PROGRAMS / ACCESSORIES / COMMUNICATIONS / HYPER TERMINAL

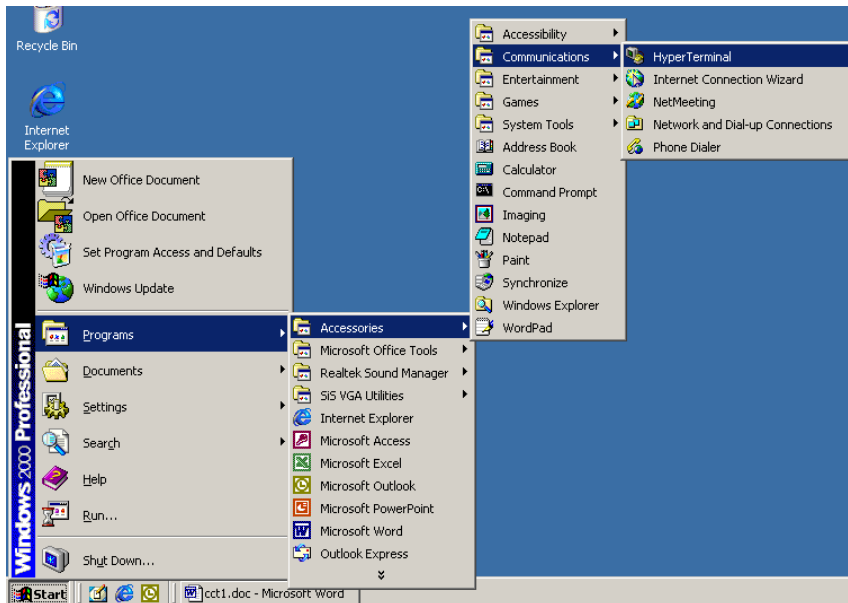

- Choose a symbol and enter a **name** (e.g. CCM 01). Confirm with **OK**.

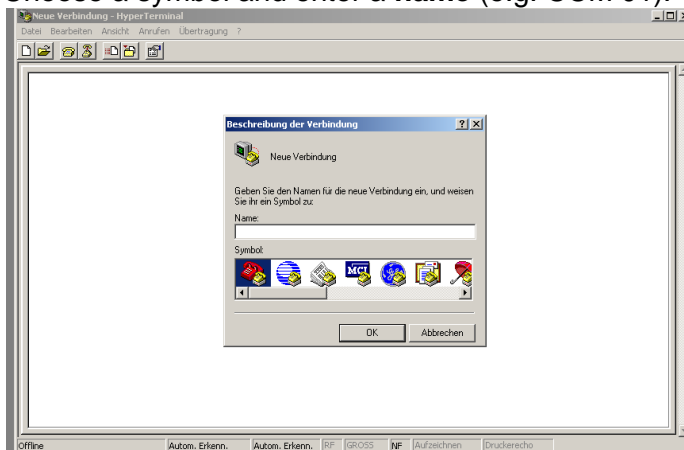

- Choose the **COM - port**



- Set the connection on your computer as follows:

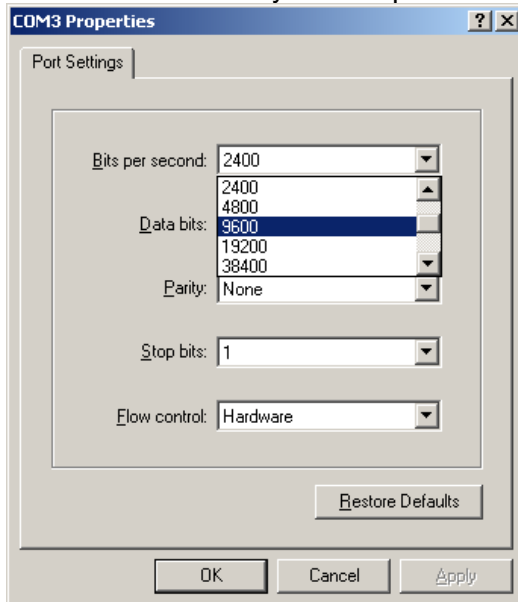

Bits per seconds: 9600 Bits
Data bits: 8
Parity: none
Stop bits: 1
Flow control: Hardware or none

3.2.3. Procedure

- Connect the CCM 01 to an external computer (RS232 or Bluetooth)
- Select „MEASURE“ in the main menu of the CCM 01 and confirm.
- Start the measuring mode with „START“.
- Stored data is provided periodically to the RS232 – interface or the Bluetooth EBT 01. The cycle can be cancelled using [ESC] after the data transfer is done.

3.2.4. Protocol for the continuous data transfer

Generally the data telegrams are developed as follows:

\$cmd(#par#par)*

- \$ marks the beginning of the data telegrams
- cmd command
- # separator
- par parameter for the command

* marks the end of a data telegram

Test reading are displayed as follows:

\$MEASURE;a.aa;b.bb;c.cc;d.dd;f.ff;dd;mm;yyyy;HH;MM;RR*

Means:

\$MEASURE: display the beginning of a new data field

a.aa: particle per 1 ml (ISO4406: $\geq 4 \mu\text{m}_{(c)}$)
or
particle per 1 ml (NAS1638: $\geq 6,4 \mu\text{m}_{(c)} = > 5 \mu\text{m}$)

b.bb: particle per 1 ml (ISO4406: $\geq 6 \mu\text{m}_{(c)}$)
or
particle per 1 ml (NAS1638: $\geq 14 \mu\text{m}_{(c)} = > 15 \mu\text{m}$)

c.cc: particle per 1 ml (ISO4406: $\geq 14 \mu\text{m}_{(c)}$)
or
particle per 1 ml (NAS1638: $\geq 21 \mu\text{m}_{(c)} = > 25 \mu\text{m}$)

d.dd: particle per 1 ml (ISO4406: $\geq 21 \mu\text{m}_{(c)}$)
or
particle per 1 ml (NAS1638: $\geq 37 \mu\text{m}_{(c)} = > 50 \mu\text{m}$)

f.ff: volume flow through the measuring channel of the sensor

dd: day (date)

mm: month (date)

yyyy: year (date)

HH: hour (time)

MM: minute (time)

RR: report format (01: ISO, 02: NAS)

***:** marks the end of a data field

Example: **\$M;371.08;29.44;2.92;0.74;50.00;02;01;2006;08;15;01***

3.3. Data transfer of the saved measurements

In the mode „**Data transfer**“ stored measurements can be transferred from the CCM 01 to an external computer.

For this purpose, connect the CCM 01 using the serial interface RS232 with the external Computer. (see chapter 3.1)

3.3.1. Export and evaluation of the stored data via “CCM 01 data manager Vers. 2.0”

- The CCM 01 DATA MANAGER software version 2.0 has been developed especially for the CCM 01 display unit and is provided on the CD-ROM.
- Connecting the CCM 01 to an external computer (see chapter 3.1) and **one-time** installation of the data manager software from the CD-ROM to the external computer is necessary.
- The data manager enables data transfer into ECXEL table.

3.3.2. One-time program installation

- Execute the CCM 01 – data manager program installation (**setup.exe**) from the provided CD-ROM. The **setup.exe** is located in the following folder on the CD-ROM: **setup\volume\ setup.exe**.
- Execute the installation as instructed and wait until the installation has been completely finished.
- In the Windows – START – menu, the folder “CCM01 Data Manager” will be generated. In this folder the data manager program “**CCM01 DataManager**” is saved.

- Start the data manager program on the computer with **CCM 01 Data Manager**.



3.3.3. Procedure

- Connect the CCM 01 to an external computer (RS232 or Bluetooth)
- Start the installed **CCM 01 Data Manger** on the **external computer**.



- Select the **required COM port** in the main menu of the data manager program..

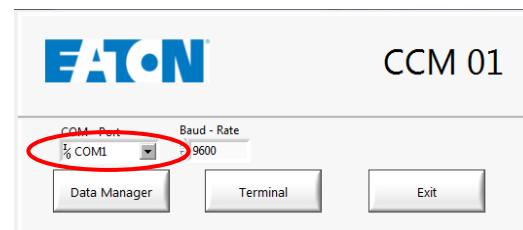

NOTICE Pay attention that the selected COM-port is consistent with the COM-port indication of the computer. (see in Windows at the device manager in data links "COM and LPT1")

NOTICE While connecting Bluetooth modul EBT 01 the virtual COM port is assigned according to the Bluetooth receiver (dongel) of the computer. (see instructions of the used Bluetooth dongel on the computer).

- Select [**DATA MANAGER**] in the **main menu of the CCM 01** and confirm with [↵].
 - Select [**TRANSFER DATA**] and confirm with [↵].
 - The saved data is provided cyclically.
 - The supply cycle can be quit with [ESC].

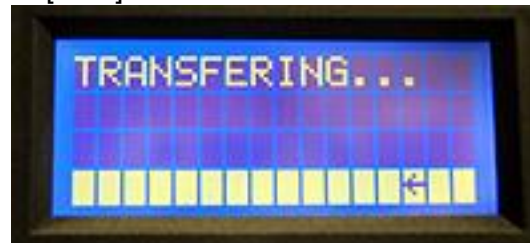

- Check the connection between the CCM 01 and the external computer by using the button „**Terminal**“ in the main menu of the data manager program.

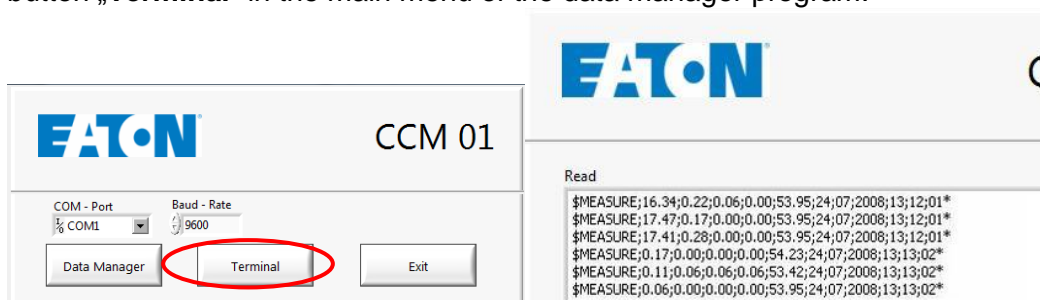

NOTICE If an empty terminal window appears, select the right COM port and check the connection again.

- (5) Clicking the button „Data Manager“ allows the export of the data and further processing of the measured data.

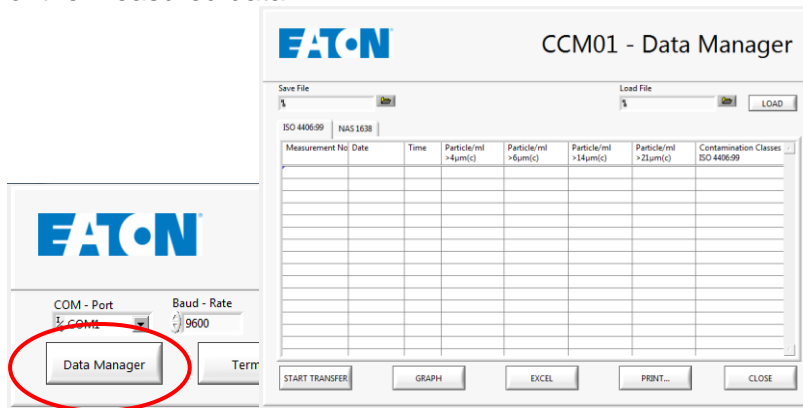

- (6) Data transfer by using the button „START TRANSFER“.

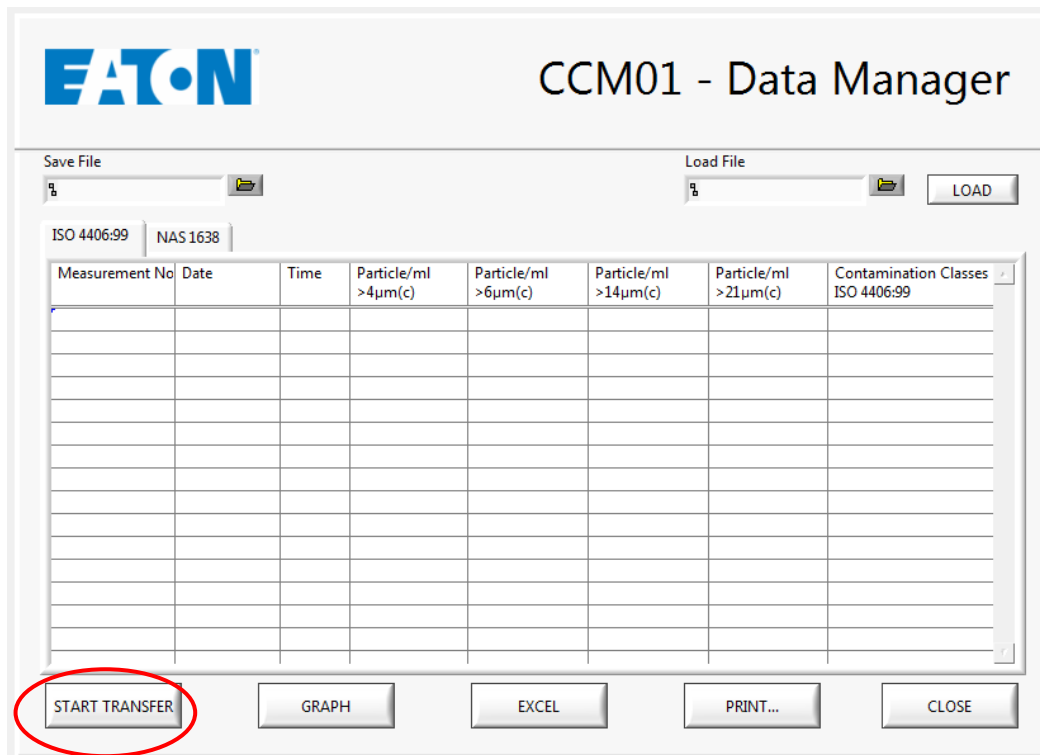

- Select path and specify filename to save the measured data.

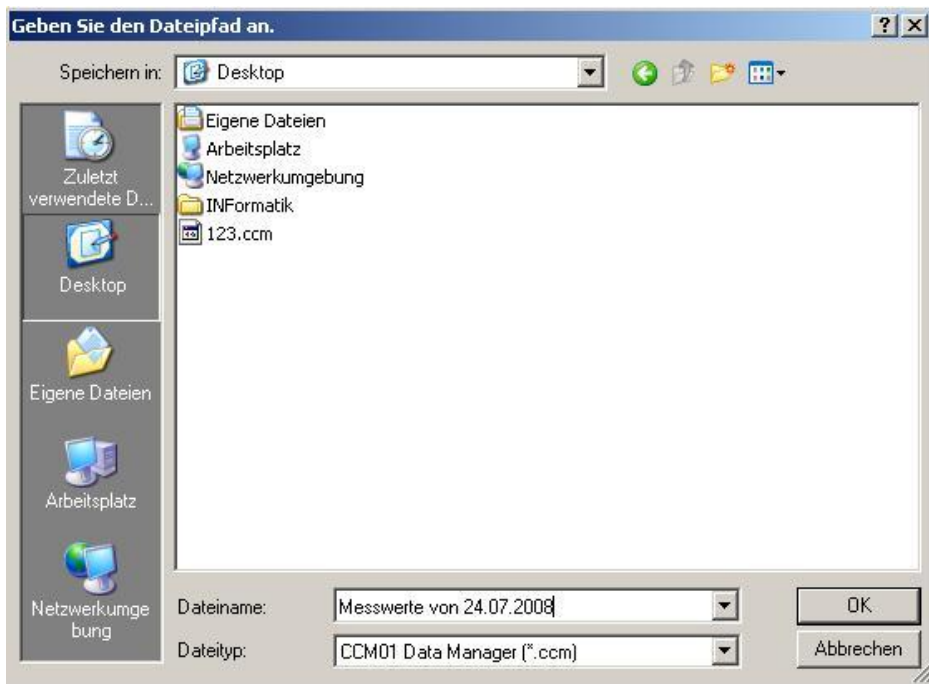

- Afterwards the data transfer starts.

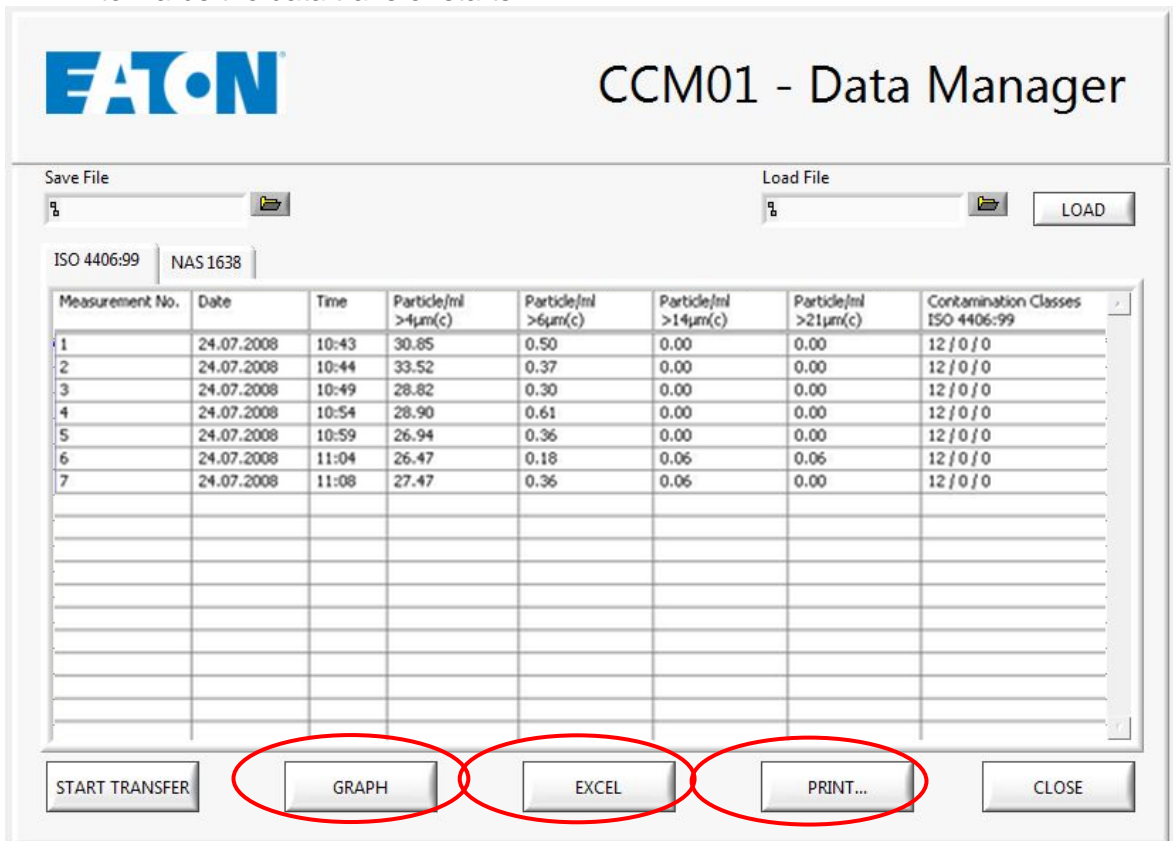

(a)

(b)

(c)

(7) The transferred data can be:

(a) charted

(b) exported in an EXCEL – data sheet

(c) printed as a report

a) Graphic display via the button „GRAPH“

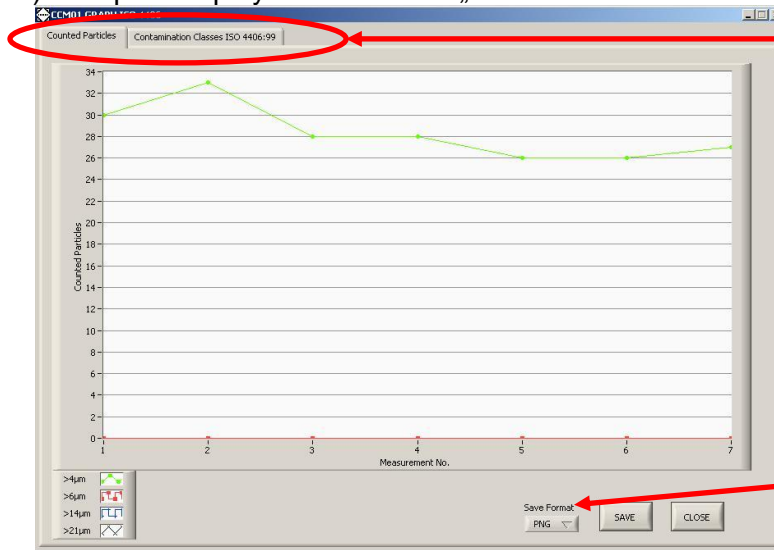

Graphic display of the:

- particle per counting channel
- contamination classes according to ISO 4406:99 or NAS 1638

The graphic can be saved as a PNG- or BMP – file.

b) Export into an Excel – data sheet via the button „EXCEL“

CCM01 Data Manager									
Measurement No.	Date	Time	Particle/ml >4µm	Particle/ml >6µm	Particle/ml >14µm	Particle/ml >21µm	ISO 4406:99 >4µm	ISO 4406:99 >6µm	ISO 4406:99 >14µm
1	24.07.2008	10:43	30,85	0,5	0	0	0	12	0
2	24.07.2008	10:44	33,52	0,37	0	0	0	12	0
3	24.07.2008	10:49	28,82	0,3	0	0	0	12	0
4	24.07.2008	10:54	28,9	0,61	0	0	0	12	0
5	24.07.2008	10:59	26,94	0,36	0	0	0	12	0
6	24.07.2008	11:04	26,47	0,18	0,06	0,06	0	12	0
7	24.07.2008	11:08	27,47	0,36	0,06	0	0	12	0

- For further processing of the data, all standard functions are available in EXCEL.

c) Printing a report via the button „PRINT“

CCM01 Report

Eaton Technologies GmbH

Measurement No.	Date	Time	Particle/ml >4µm(c)	Particle/ml >6µm(c)	Particle/ml >14µm(c)	Particle/ml >21µm(c)	Contamination Classes ISO 4406:99
1	24.07.2008	10:43	30.85	0.50	0.00	0.00	12 / 0 / 0
2	24.07.2008	10:44	33.52	0.37	0.00	0.00	12 / 0 / 0
3	24.07.2008	10:49	28.82	0.30	0.00	0.00	12 / 0 / 0
4	24.07.2008	10:54	28.90	0.61	0.00	0.00	12 / 0 / 0
5	24.07.2008	10:59	26.94	0.36	0.00	0.00	12 / 0 / 0
6	24.07.2008	11:04	26.47	0.18	0.06	0.06	12 / 0 / 0
7	24.07.2008	11:08	27.47	0.36	0.06	0.00	12 / 0 / 0

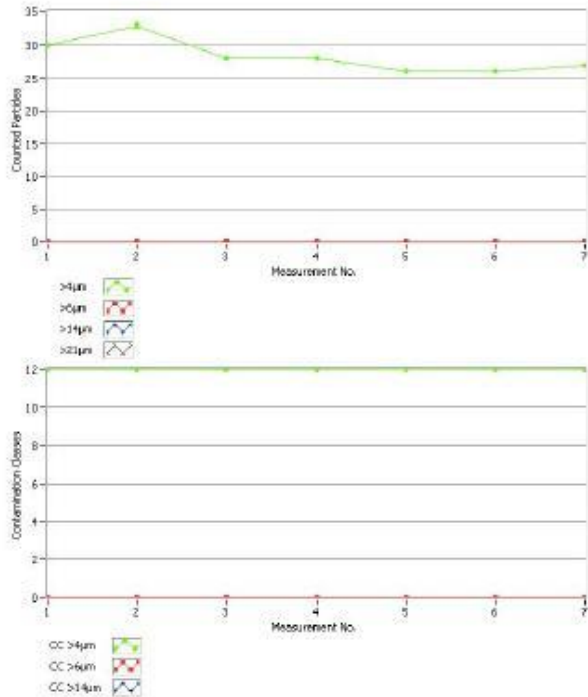

1 of 1

(8) Closing the data manager software via the button „CLOSE“.

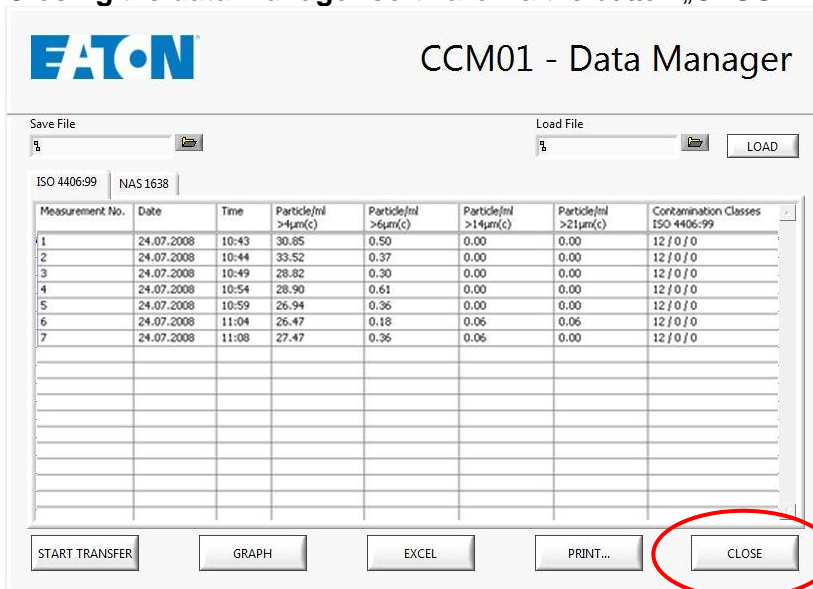

4. Evaluating measurements

- The **contamination classes**, calculated on the basis of the determined particle numbers each counter channel, will be **displayed** according to the selection type (ISO 4406 or NAS 1638). (see chapter 2.8.3.1.2)

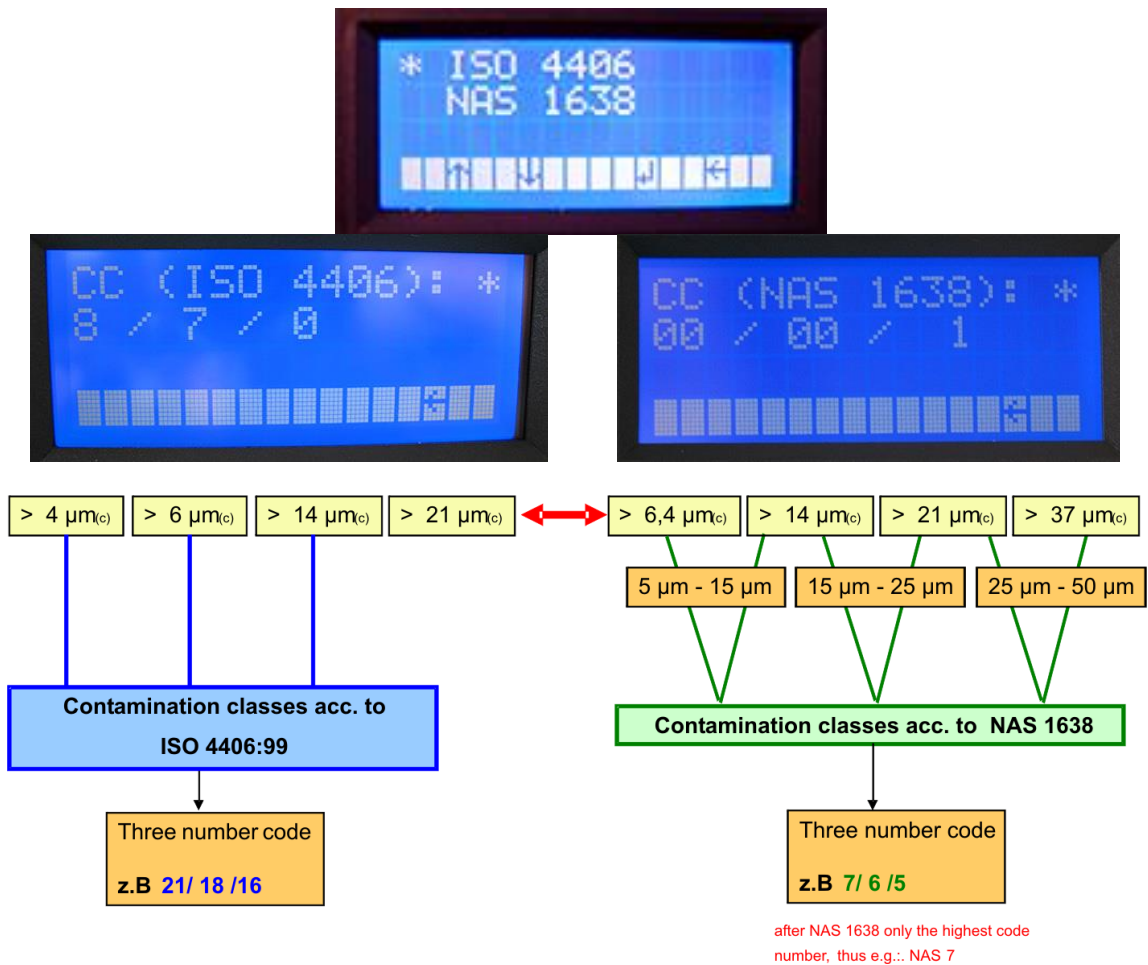

- The actual particle numbers saved according to the selected classification type per counting channel can be forwarded to an external computer by means of RS232 interface or bluetoothmodule EBT01 and by applying the supplied data manager software 2.0 or another communication programme; they can be edited and administered.

Microsoft Excel - Mappe1											
Datei Bearbeiten Ansicht Einfügen Format Extras Daten Fenster ?											
Arial 10 F X U % 000											
	A	B	C	D	E	F	G	H	I	J	
1			CCM01 Data Manager								
2											
3	Measurement No.	Date	Time	Particle/ml >4µm	Particle/ml >6µm	Particle/ml >14µm	Particle/ml >21µm	ISO 4406:99 >4µm	ISO 4406:99 >6µm	ISO 4406:99 >14µm	
4	1	24.07.2008	10:43	30,85	0,5	0	0	12	12	0	
5	2	24.07.2008	10:44	33,52	0,37	0	0	12	12	0	
6	3	24.07.2008	10:49	28,82	0,3	0	0	12	12	0	
7	4	24.07.2008	10:54	28,9	0,81	0	0	12	12	0	
8	5	24.07.2008	10:59	26,94	0,36	0	0	12	12	0	
9	6	24.07.2008	11:04	26,47	0,18	0,06	0,06	12	12	0	
10	7	24.07.2008	11:08	27,47	0,36	0,06	0	12	12	0	
11											

It is also possible to print a singular report by using the external printer.

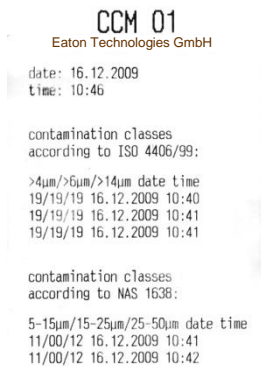

(The detailed description see in chapter 3 and 2.8.3.2.1.2)

5. CAN interface

- The CCM 01 has additionally a CAN interface.
- The physical CAN interface complies with the Norm ISO 11898 and is electrically isolated with optocouplers.
- With this interface all settings which can be made with the keypad are also practicable.
- The communication protocol is compatible to CANopen, but there is no support to all specified CANopen-functions.
- In this chapter there is a small introduction to the fieldbus system CAN and the higher layer protocol CANopen and a description of controlling the CCM 01 via CAN.

5.1. Introduction to CAN and CANopen

5.1.1. CAN-Bus

- CAN-Bus is an asynchronous, serial fieldbus system. Primarily it was developed by “Bosch” in 1983 for the automotive industry to make networking of control units in cars easier. Because of capability to control also larger systems, CAN-Bus became an industrial standard.
- CAN-Bus is based on a data exchange with an identification of the transmitted message. This is called the identifier. It has a length of 11 bit and it also determines the priority of the message. The smaller the identifier the higher the priority. The message which follows the identifier can contain up to 8 byte data. The setup of one CAN telegramme is to be seen in the next illustration.

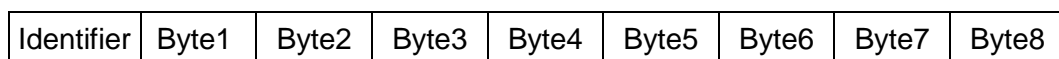

- Therefore CAN defines only the data transmission but not the meaning of a message. This is specified by the higher layer protocol CANopen.

5.1.2. CANopen

- CANopen is a standard of the CAN-in-Automation. The general functionality is described in the specification DS-301.
- The central element of the CANopen standard is the object dictionary. It is the interface between the network and the application. It contains general informations about the device, all measured values and parameter.

- The objects or parameters are addressed with a 16-bit index and an 8-bit subindex. The build-up of the object dictionary and the access to it is described in the following chapters. CANopen defines different objects for communication.

These are:

- Service Data Object (SDO): For parameter settings
- Process Data Object (PDO): For transmitting process data
- Network Management Object (NMT): For changing the state of a device
- Emergency Object: For transmitting error and alarm messages
- Timestamp Object: For adjusting the time

- The differentiation of these communication objects results from the identifier. The identifier is separated in two parts.
- The most significant 4 bit describe the function code which declares the type of the message, the remaining 7 bit describe the Node ID.
- This separated identifier is called the Communication Object Identifier (COB-ID). Therefore it is possible in this broadcast system to communicate with single participants.

Functions code				Node ID						
Bit10	Bit9	Bit8	Bit7	Bit6	Bit5	Bit4	Bit3	Bit2	Bit1	Bit0

- The meaning of the function code is arranged in the so-called Pre-defined connection set.

Object	Function code (binary)	Resulting COB-ID (dec)
NMT	0000	0
SYNC	0001	128
EMCY	0001	129 - 255
PDO1 (tx)	0011	385 - 511
PDO1 (rx)	0100	513 - 639
PDO2 (tx)	0101	641 - 767
PDO2 (rx)	0110	769 - 895
PDO3 (tx)	0111	897 - 1023
PDO3 (rx)	1000	1025 - 1151
PDO4 (tx)	1001	1153 - 1279
PDO4 (rx)	1010	1281 - 1407
SDO (tx)	1011	1409 - 1535
SDO (rx)	1100	1537 - 1663
NMT Error Control	1110	1793 - 1919

5.2. CANopen – functionality

- The CCM01 does not have the complete CANopen – functionality.
- The following functions of CANopen are available:
 - Object dictionary with all measured data and parameters
 - One SDO-Server → For parameter settings
 - One transmit PDO → For transmitting the measured data
 - Nodeguarding or Heartbeat
 - Emergency object for error or alarm messages
 - Timestamp for adjustment of time
 - NMT-State-Machine

5.3. Start-up

- For starting the controlling with CAN you must proceed as follows.



- Choose the submenu CAN with the [↑↓] buttons. Enter the chosen menu item by hitting the [↵] button.
- Now there is the menu for adjusting the baudrate, the node ID and for starting the controlling with CAN. These settings are basically for communication with CAN.



5.3.1. Baudrate



- Use the [↑↓] button to choose the baudrate.
- The following baudrates can be chosen:
 - 10 kbit/s
 - 20 kbit/s
 - 50 kbit/s
 - 125 kbit/s
 - 250 kbit/s
 - 500 kbit/s
 - 800 kbit/s
 - 1 Mbit/s (1000 kbit/s)
- Confirm by hitting the [↵] button and automatic return to the [CAN] – menu.
- Use [ESC] to go back to the previous menu – changes will not be adopted.

NOTICE The default baudrate is 125 kbit/s.

5.3.2. Node ID



- By hitting the [↵] button, the position that has to be changed can be switched.
- The [↑↓] buttons set a new parameter.
- The values of the **node ID** must be between **1** and **127**.
- Confirm by hitting the [↵] button – automatic return to the [CAN] – menu.

- Use [**ESC**] to go back to the previous menu – changes will not be adopted.
NOTICE The default node ID is 1.

5.3.3. Start



- For starting the controlling with CAN use the [↑↓] buttons to select the item **START**.
- Confirm by hitting the [↵] button.
- Now all parameter settings can be made with the CAN-protocol which is described in the following.
- When the device is switched-off during the CAN-mode, it goes in this mode again after a reset.
- Use [**ESC**] to leave the CAN-mode.
- After that there is the **initialisation phase**, followed from the **Bootup – message**. This message has the following buildup:

Identifier	Data
700h + Node ID	00h

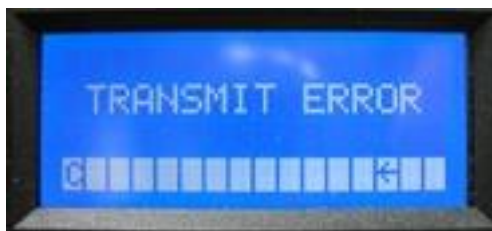

- If this message **could not be sent** there is a message “**TRANSMIT ERROR**” on the display for 1 second.



- **After** this message the state **Pre-Operational** is achieved.
- In the menu bar you can see a “**c**”.
- This is the sign that the device is now controlled with CAN. The state of the device is shown on the display.

- As soon as the device is put into the state Operational, measurement is started. In this state the contamination classes are shown on the display according to the chosen report format.

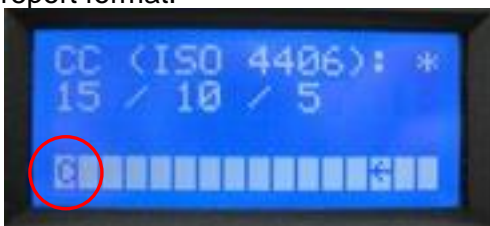

5.4. Object dictionary

- The object dictionary has a buildup like a table with lines and columns.
- An entry of the object dictionary is addressed with an index and a subindex.

- The object dictionary of the CCM01 is subdivided into two parts:
 - communication specific part
 - manufacturer specific part
- All parameters and measured values are accessible via the standard-SDO with an index and a subindex.
- In general changes after a writing access are accepted immediately and remain after a reset.
- In the following chapters the two parts of the object dictionary are described with the index, subindex, data type and access and default value.

5.4.1. Communication specific part

Index (hex)	Subindex (hex)	Description	Data type	Access	Default value
1000	0	Device Type	UNS32	ro	12Dh
1001	0	Error Register	UNS8	ro	0
1002	0	Manufacturer Status Register	UNS32	ro	0
100C	0	Guard Time	UNS16	ro	0
100D	0	Life Time Factor	UNS8	ro	0
1010	Store Parameter Field				
	0	Number of Entries	UNS8	ro	1
	1	Save all Parameters	UNS32	ro	2
1012	0	COB-ID Time Stamp Object	UNS32	rw	100h
1014	0	COB-ID Emergency Object	UNS32	ro	80h + NID
1017	0	Producer Heartbeat Time	UNS16	rw	0
1200	Server SDO Parameter				
	0	Number of Entries	UNS8	ro	2
	1	COB-ID Client Server	UNS32	ro	600h + NID
	2	COB-ID Server-Client	UNS32	ro	580h + NID
1800	Transmit PDO1 Communication Parameter				
	0	Number of Entries	UNS8	ro	2
	1	COB-ID used by PDO	UNS32	ro	180h + NID
	2	Transmission Type	UNS8	ro	FEh
1A00	Transmit PDO1 Mapping Parameter				
	0	Number of Entries	UNS8	ro	4
	1	1. Mapped Object	UNS32	ro	50000110h
	2	2. Mapped Object	UNS32	ro	50000210h
	3	3. Mapped Object	UNS32	ro	50000310h
	4	4. Mapped Object	UNS32	ro	50000410h

5.4.1.1. Error register (Index 1001h)

- The error register shows the error status of the device.
- When an error occurs or adjusted limits are exceeded bit 0 is set (general error).
- The reason of this error is indicated with the manufacturer status register.
- The content of this error register is transmitted in every emergency message.

5.4.1.2. Manufacturer status register (Index 1002h)

- This register shows the actual state of all detectable errors.
- Every bit stands for a specific error.
- If a bit is set this error is active.
- The buildup of this register is as follows:

Manufacturer Status Register								
Bit8	Bit7	Bit6	Bit5	Bit4	Bit3	Bit2	Bit1	Bit0
Limit 5 – 15 µm	Limit 15 – 25 µm	Limit 25 – 50 µm	Limit 50 µm	Limit 4 µm	Limit 6 µm	Limit 14 µm	Limit 21 µm	Flow Sensor

- Bit 0 is set when no valid signal of the flow sensor is detected.
- Bits 0 – 4 are set when an adjusted limit value is exceeded and the report format is according ISO 4406.
- Bits 5 – 8 are set when an adjusted limit value is exceeded and the report format is according NAS 1638.
- Bits 9 – 31 are unused.
- The content of this register is sent at every emergency message.

5.4.2. Manufacturer specific part

- In this chapter the manufacturer specific part of the object dictionary is described.
- The following table shows the buildup of this part.

Index (hex)	Subindex (hex)	Description	Data type	Access	Default value
3000	0	Limit 4 µm	UNS8	rw	0
3001	0	Limit 6 µm	UNS8	rw	0
3002	0	Limit 14 µm	UNS8	rw	0
3003	0	Limit 21 µm	UNS8	rw	0
3004	0	Limit 5 – 15 µm	UNS8	rw	0
3005	0	Limit 15 – 25 µm	UNS8	rw	0
3006	0	Limit 25 – 50 µm	UNS8	rw	0
3007	0	Limit 50 µm	UNS8	rw	0
3008	0	Report Format	UNS8	rw	1
3009	0	Viscosity Range	UNS8	rw	2
300A	0	Sending Measurement Results	UNS16	rw	0
4000	0	Storage Interval	UNS16	rw	0
4001	0	Number of stored data	UNS16	rw	0
4002	Stored Data1		RECORD	ro	
.
.
.
4065	Stored Data100		RECORD	ro	
5000	Process values as UNS16				
	0	Number of Entries	UNS8	ro	5
	1	Contamination class 1. channel	UNS16	ro	(value)
	2	Contamination class 2. channel	UNS16	ro	(value)
	3	Contamination class 3. channel	UNS16	ro	(value)
	4	Contamination class 4. channel	UNS16	ro	(value)
	5	Volume flow	UNS16	ro	(value)
5100	Process values as Real32				
	0	Number of Entries	UNS8	ro	5
	1	Particle number 1. channel	REAL32	ro	(value)
	2	Particle number 1. channel	REAL32	ro	(value)
	3	Particle number 1. channel	REAL32	ro	(value)
	4	Particle number 1. channel	REAL32	ro	(value)
	5	Volume flow	REAL32	ro	(value)

5.4.2.1. Threshold settings

- The indexes **3000h to 3007h** of the **object dictionary** are for threshold settings.
- The limit values according ISO 4406 can be changed at the index **3000h – 3003h**.
- The limit values according NAS 1638 can be changed at the index **3004h – 3007h**.
- The value “**0**” stands for deactivation of limit values monitoring.
- At the threshold setting according **NAS 1638** the decimal value **13** is equivalent to contamination class “**00**” and the decimal value **14** is equivalent to contamination class “**0**”.

5.4.2.2. Report format

- At the index 3008h the classification can be changed.
- The value 1 means a classification according ISO 4406, the value 2 means a classification according NAS 1638.

NOTICE This adjustment should not be made in the state operational.

5.4.2.3. Viscosity range

- At the index 3009h the viscosity range can be changed.
- The context between the value and the viscosity range is illustrated in the next table.

Value	1	2	3
Viscosity range (mm ² /s)	10...33	33...250	> 250

5.4.2.4. Sending measurement results

- Transmission of the PDO takes place after the number of measurements which can be changed Index 300Ah.
- The time of one measurement is 20 seconds.
- That means that at a value of 1 the result is sent after every measurement (every 20 seconds).
- With a value of 0 the results are not transmitted.

5.4.2.5. Storage interval

- The storage interval is at the index 4000h.
- The unit is minutes and it can be changed between 0 (storage interval off) and 10080 (7 days).

5.4.2.6. Stored data

- At the index 4001h there is the number of the stored measurement results.
- 100 measurements can be stored.
- Deletion can be made with a writing access to the index 4001h, subindex 0h and the value 0.
- The stored data are at the following indexes.
- The first possible data set is at index 4002h, the last one at index 4065h.
- At a query of not existing data sets the abort code “06010000h” (Unsupported acces to an object) is sent.
- Following there is the buildup of one data set.

Index (hex)	Subindex (hex)	Description	Data type	Access	Default value
4002	0	Number of entries	UNS8	ro	11
	1	Day	UNS8	ro	
	2	Month	UNS8	ro	
	3	Year	UNS8	ro	
	4	Hour	UNS8	ro	
	5	Minute	UNS8	ro	

	6	Report format	UNS8	ro	
	7	Particles/ml 1. channel	REAL32	ro	
	8	Particles/ml 2. channel	REAL32	ro	
	9	Particles/ml 3. channel	REAL32	ro	
	A	Particles/ml 4. channel	REAL32	ro	
	B	Volume flow	REAL32	ro	

5.4.2.7. Process values

- Process values are contamination classes acc. ISO 4406 or NAS 1638 and the volume flow in the measuring channel.
- These are at index 5000h as Unsigned16 – values.
- At index 5100h there are the particle numbers and the volume flow as Real32 – value.
- The unit of the volume flow is ml/min.

5.5. SDO (Service Data Object)

- With Service Data Objects the access to entries of a device Object Dictionary is provided.
- It is a client-server communication.
- A client request is always confirmed by a reply from the server.
- The CCM 01 represents an SDO-Server.
- For an SDO transfer following COB-IDs are used:

COB-ID	Description
0x600 + Node ID	SDO Client → CCM01
0x580 + Node ID	CCM01 → SDO Client

- At an SDO the 8 byte data consist of the Command Specifier (CS), a 16 – Bit index, an 8 – Bit subindex and maximum 4 byte data.
- The buildup is shown in the next illustration.

Byte 0	Byte 1	Byte 2	Byte 3	Byte 4	Byte 5	Byte 6	Byte 7
CS	Index		Subidx	Data			

- At an SDO request the Command Specifier indicates the type of request (read or write).
- With a writing acces it contains also information about the number of bytes in the data field.
- At an SDO response the Command Specifier indicates the success of the request.
- At a reading request it also contains information about the number of bytes in the data field.
- When the request was not successful the data field contains a 4 byte error code.
- The meaning of these error codes is described in the specification DS-301.

CS (hex)	Description	Type of telegramme
2F	Write 1 Byte	Request
2B	Write 2 Byte	Request
27	Write 3 Byte	Request
23	Write 4 Byte	Request
60	Writing successful	Response
80	Error	Response
40	Reading request	Request
4F	1 Byte data	Response
4B	2 Byte data	Response
47	3 Byte data	Response

43	4 Byte data	Response
----	-------------	----------

NOTICE The CCM 01 supports only the transmission of data with a maximum length of 4 Byte!

5.6. Transmit PDO

- The CCM 01 has one Transmit PDO (TPDO).
- This contains the measurement results in contamination classes according ISO 4406 or NAS 1638.
- The identifier is static (180h + Node ID).
- The transmission type is 254 und also static. That means the transmission type is defined in the manufacturer specific part of the object dictionary. It was described in section 5.4.2.4.
- PDO Mapping is also static and it is described in the next illustration.

Byte 0	Byte 1	Byte 2	Byte 3	Byte 4	Byte 5	Byte 6	Byte 7
Idx 5000, Sidx 1		Idx 5000, Sidx 2		Idx 5000, Sidx 3		Idx 5000, Sidx 4	

- The Transmit PDO can also be requested with a Remote Frame.

5.7. Emergency Messages

- With an exceeding of the limit values or with an error of the flow sensor an emergency message will be sent.
- The identifier is 80h + Node ID.
- The message consists of the Emergency Error Code, the Error Register and the Manufacturer Status Register.
- The type of error is indicated by the Manufacturer Status Register (5.4.1.2).

Byte 0	Byte 1	Byte 2	Byte 3	Byte 4	Byte 5	Byte 6	Byte 7
Emergency Error Code		Error Reg.	Manufacturer Status Register				unused

5.8. Guarding

- For guarding Heartbeat- or Nodeguarding-mechanism can be used.
- It can only be used one error control mechanism at the same time.

5.8.1. Nodeguarding

- The CCM01 only supports Nodeguarding.
- Lifeguarding is not supported.
- An NMT Master cyclically sends a remote frame to an NMT Slave.
- The identifier is 700h + Node ID.
- The response of the NMT slave contains the state of that NMT Slave and an alternating toggle bit.
- An error is indicated if the remote transmit request is not confirmed within the node life time or the reported NMT slave state does not match the expected state.
- Nodeguarding is only possible when the parameter "Producer Heartbeat Time" (1017h) is 0.

5.8.2. Heartbeat

- The Heartbeat mechanism defines an Error Control Service without need for remote frames.
- A Heartbeat Producer transmits a Heartbeat message cyclically.

- The identifier is 700h + Node ID and it contains the MT state of the NMT Slave.
- It is activated when the parameter “Producer Heartbeat Time” (1017h) is bigger than 0.

5.9. Timestamp

- The Timestamp-Object can be used for setting the time.
- This protocol is a timestamp with a length of 6 Byte. It consists of the days since 1. January 1984 and the milliseconds after midnight.
- The default value of the identifier is 100h. It can be changed at the index 1012h. A receipt for the timestamp is only possible in the state Pre-Operational and when the MSB of the Object 1012h is 1.

5.10. Network Management

- The state machine is implemented according DS-301. The CCM 01 supports the following orders:
 - Start Remote Node
 - Stop Remote Node
 - Enter Pre-Operational
 - Reset Node
 - Reset Communication

5.11. EDS-file

- For the CCM01 an electronic data sheet (EDS-file) is available. It contains a complete description of the object dictionary and it serves for an easy integration in a CANopen configuration tool.

5.12. Examples for CAN-communication

- In this chapter there are some examples for controlling the CCM 01 via CAN. All numbers are in hexadecimal representation.

Node ID 5, request limit 4 µm:

	Identifier	8 Byte Data
Client	605	40 00 30 00 00 00 00 00
Response CCM 01	585	4F 00 30 00 xx 00 00 00

Node ID 5, set viscosity range to 10...33 mm²/s:

	Identifier	8 Byte Data
Client	605	2F 09 30 00 01 00 00 00
Response CCM 01	585	60 09 30 00 00 00 00 00

Node ID 15, request particle number 1. channel:

	Identifier	8 Byte Data
Client	60F	40 00 51 01 00 00 00 00
Response CCM 01	58F	43 00 51 01 xx xx xx xx

Node ID 15, Start Remote Node:

	Identifier	2 Byte
Master	0	01 0F oder 01 00

6. Sensor calibration

- The laser sensor is calibrated with ISO MTD according to ISO 11171 and is to delivered with a calibration certificate.
- 12 months are the validity of the calibration certificate.

- Eaton recommends a calibration interval of 1 year. For the secondary calibration send the sensor to Eaton Technologies GmbH in Altlußheim.
- The calibration and maintenance package for the sensor contains:
 - Function test of the sensor and the CCM 01
 - Calibration with calibration certificate
 - Programming of the new calibration values in the CCM 01
 - 24 h function test
- Upon delivery the calibration values of the attached laser sensor are programmed in the CCM 01.
- When only the PFS 01 sensor was sent to calibration, the calibration values must be entered into the CCM 01.
- If the laser sensor is recalibrated or exchanged, also the programmed calibration values in the CCM 01 have to be changed. The input of the new calibration values is described in chapter 2.8.3.3.3

7. Appendix

7.1. Technical Data

7.1.1. Laser sensor

Measuring principle:	Particle counting based on the light blockade principle
Calibration of particle sizes:	ISO MTD in oil (ISO 11171:2000)
Limit of coincidence:	10.000 particles / ml (5 %)
Maximum acceptable operating pressure:	≤ 50 bar / ≤ 725 psi
Maximum oil temperature:	70 °C / 158 °F
Viscosity range:	10.....400 mm ² /s / 45...1854 SUS
Ambient temperature:	0...+ 70 °C / 32...158 °F
Minimum volume flow:	500 ml/ min / 0,132 gal/ min
Maximum acceptable volume flow:	50 l/min / 13,3 gal/ min
Connections:	Pipes 1" or ¾"
Connector plug:	Sub D
Protection class:	IP 65
Weight:	1,5 kg / 3,3 lb (m)
Operating fluids:	Mineral oil based hydraulic- and lubricating fluids (see separate list for compatibility)

7.1.2. CCM 01 – Display unit

Measuring method:	Automatic particle counting
Particle sizes (switchable):	> 4 μm _(c) , > 6 μm _(c) , >14 μm _(c) , > 21 μm _(c) , <u>or</u> > 6,4 μm _(c) , >14 μm _(c) , > 21 μm _(c) , > 37 μm _(c)
Display of contamination classes:	ISO 4 - 24 NAS 00 – 12
Accuracy of measurement: (contamination classes)	± 1
Display:	4 – rows with 16 digits each
Ambient temperature:	0 ...+ 70 °C / 32...158 °F
Controls:	4 – buttons
Protection class:	IP 65
Power supply:	+ 24 V DC
Ripple:	< 300 mV _{PP}
Storage capacity:	100 measurements

Serial interface:	RS 232 (Baudrate: 9600 Bits, data bits: 8, parity: none, stop bits: 1, flow control: hardware)
CAN interface:	ISO 11898, CAN 2.0A, CANopen compatible
Threshold contacts:	4 x open – relay contacts
Max. threshold contact load:	30 V AC/ DC – 1A
Fuse:	160 mA (slow-blow)

7.1.3. CCM 01 – housing

Material:	ABS (Acrylonitrile butadiene styrene) and polycarbonate
Sealing material:	EPDM (Ethylene/ Propylene – Dien polymer)
Protection class:	IP 65
Dimensions:	160 x 185 x 110 mm x mm x mm
Weight:	1,28 kg

7.1.3.1. CCM 01 - backside of housing

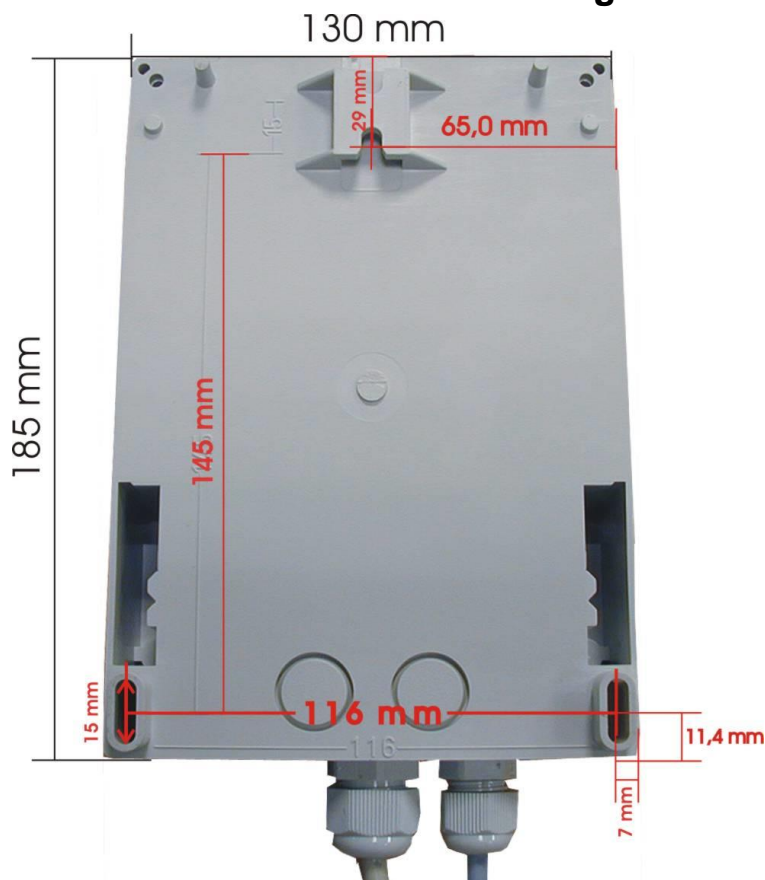

7.2. Pin assignment

7.2.1. Laser sensor

Connection color (connection cable):

1: blue	(→ 4...20 mA flow rate sensor
2: green	(→ laser particle sensor
3: grey	→) - 12 V DC
4: yellow	→) + 12 V DC
5: black	GND
6: white	GND
7: brown	→) + 5 V DC

X11
2
5
13
14
15 (review 2.6)
16
18

7.2.2. CCM 01 – display unit

7.2.2.1. RS 232 interface and CAN – option

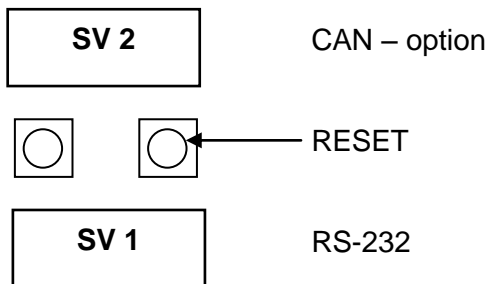
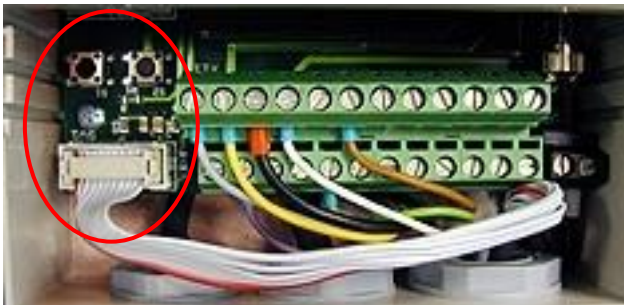

7.2.2.2. Sensor connections – X11

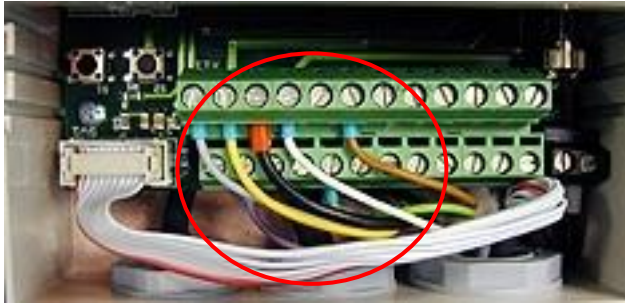

13	14	15	16	17	18	19	20	21	22	23	24
1	2	3	4	5	6	7	8	9	10	11	12

- 1:
- 2: blue - (→) 4...20 mA flow rate sensor
- 3:
- 4:
- 5: green - (→) laser particle sensor
- 6:
- 7: GND
- 8: GND
- 9: REL 4 contact 1 (4 $\mu\text{m}_{(c)}$ / 5 – 15 μm)
- 10: REL 3 contact 1 (6 $\mu\text{m}_{(c)}$ / 15 – 25 μm)
- 11: REL 2 contact 1 (14 $\mu\text{m}_{(c)}$ / 25 – 50 μm)
- 12: REL 1 contact 1 (21 $\mu\text{m}_{(c)}$ / > 50 μm)
- 13: grey - (→ - 12 V DC
- 14: yellow - (→ + 12 V DC
- 15: black – GND (review 2.6)
- 16: white - GND
- 17: GND
- 18: (→ + 5 V DC
- 19:
- 20:
- 21: REL 4 contact 2 (4 $\mu\text{m}_{(c)}$ / 5 – 15 μm)
- 22: REL 3 contact 2 (6 $\mu\text{m}_{(c)}$ / 15 – 25 μm)
- 23: REL 2 contact 2 (14 $\mu\text{m}_{(c)}$ / 25 – 50 μm)
- 24: REL 1 contact 2 (21 $\mu\text{m}_{(c)}$ / > 50 μm)

7.2.2.3. Power supply – 24 V DC



24V	⊥
-----	---

7.3. Pressure difference characteristics

Pressure difference characteristics of the PFS 01 mit HLP 46

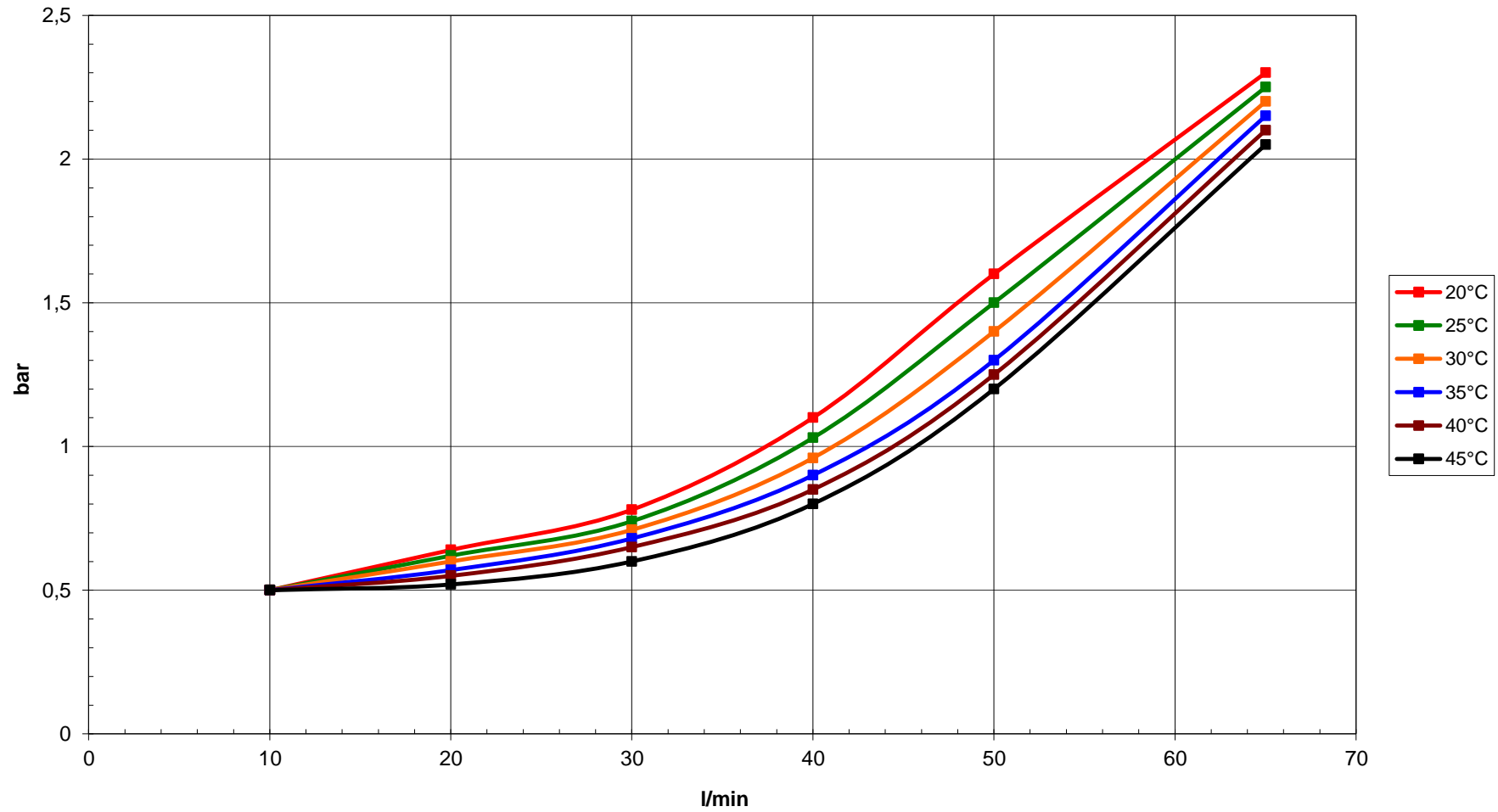

7.4. Cleanliness classes according to ISO 4406:99

According to ISO 4406 (year 1999) the number of particles sized $> 4 \mu\text{m}_{(c)}$, $> 6 \mu\text{m}_{(c)}$ and $> 14 \mu\text{m}_{(c)}$ is being used to determine the cleanliness class. The determination of the cleanliness class doesn't depend on the particle size.

Example of presenting:

20 / 16 / 12

Partikel $> 14 \mu\text{m}_{(c)}$

Partikel $> 6 \mu\text{m}_{(c)}$

Partikel $> 4 \mu\text{m}_{(c)}$

Analysis volume: 1 ml

Cleanliness class	Number of particles	Up to and including
26	320000	640000
25	160000	320000
24	80000	160000
23	40000	80000
22	20000	40000
21	10000	20000
20	5000	10000
19	2500	5000
18	1300	2500
17	640	1300
16	320	640
15	160	320
14	80	160
13	40	80
12	20	40
11	10	20
10	5	10
9	2,5	5
8	1,3	2,5
7	0,6	1,3
6	0,3	0,6

7.5. Cleanliness classes according to NAS 1638

Analysis volume: 100 ml

Particle number $\times 10^3$

Class	5 - 15 μm	15 - 25 μm	25 - 50 μm	50 - 100 μm	> 100 μm
00	0,125	0,022	0,004	0,001	0
0	0,250	0,044	0,008	0,002	0
1	0,5	0,089	0,016	0,003	0,001
2	1	0,178	0,032	0,006	0,001
3	2	0,356	0,063	0,011	0,002
4	4	0,712	0,126	0,022	0,004
5	8	1,425	0,253	0,045	0,008
6	16	2,85	0,506	0,090	0,016
7	32	5,7	1,012	0,18	0,032
8	64	11,40	2,025	0,36	0,064
9	128	22,8	4,05	0,72	0,128
10	256	45,6	8,1	1,44	0,256
11	512	91,2	16,2	2,88	0,512
12	1024	182,4	32,4	5,76	1,024

7.6. Application areas - Compatibility

- Hydraulic oils H, HL, HLP, and HV
- Gear oils C, CL, CLP
- Motor oils, gas oils
- MIL-H-5606 E
- Vegetable oils (HTG, Triglyceride)
- Synthetic ester (HEES)

7.7. Trouble shooting

No settings of the CCM 01 are done by the operator.

Malfunctions, which could be eliminated by the operator, are limited to cleaning the sensor and checking cables for breaks.

Any other case requires sending in the sensor or the display unit CCM 01 to Eaton Technologies GmbH in order to recover the functions.

A brief description of the problem would expedite the trouble shooting and the repair process. To check your warranty and to answer questions by phone we need the serial number and the date of purchase of the instrument.

7.8. Shipment



	Article no.:
(1) Monitor CCM 01	327153
(2) Sensor PFS 01	327213
(3) Sensor cable, L = 5 m	327320
(4) RS232 – connecting plug	335649
(5) RS232 – connecting cable	326762
(6) Data manager CD	327284
(7) Instruction manual	

Optional:

1. Voltage supply 24 V, 625 mA	329932
2. Waterproof data cable (fixed connected)	329931
3. EBT 01	334002
4. Printer	338250
5. USB to RS232 adaptor plug	336300

For more information:

WEB: FLTR.com.au PHONE: (+61) 1300 62 4020 EMAIL: info@FLTR.com.au SKYPE: Purple.Engineering

For more information:

WEB: FLTR.com.au **PHONE:** (+61) 1300 62 4020 **EMAIL:** info@FLTR.com.au **SKYPE:** Purple.Engineering

