

Series LF 251-631 DN40-65 PN32

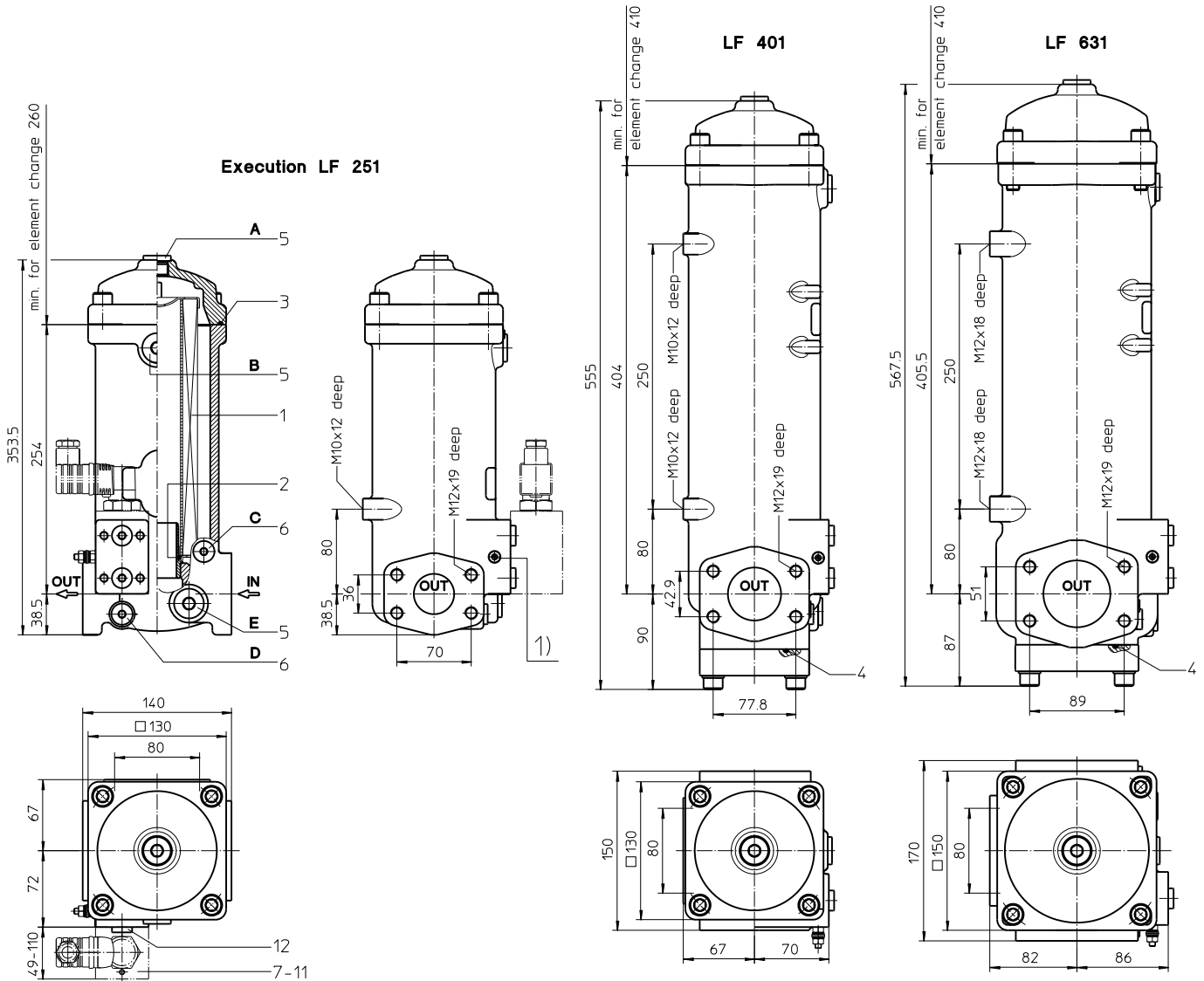

Assignment of connections and functions

- A: air bleeding G1/2
- B: air bleeding G1/2
- C: mini-measuring connection G1/4 dirt side
- D: mini-measuring connection G1/4 clean side
- E: drain G1/2 dirt side

- 1) Connection for the potential equalization, only for application in the explosive area.

Weight LF 251: approx. 14 kg
 Weight LF 401: approx. 21 kg
 Weight LF 631: approx. 29 kg

Dimensions: mm

Designs and performance values are subject to change.

EDV 08/19

For more information:

WEB: FLTR.com.au PHONE: (+61) 1300 62 4020 EMAIL: info@FLTR.com.au SKYPE: Purple.Engineering



Pressure Filter

Series LF 251-631

DN40-65 PN32

Description:

In-line filters of the type LF 251-631 are suitable for a working pressure up to 32 bar. Pressure peaks are absorbed with a sufficient margin of safety. It can be used as suction filter, pressure filter and return-line filter.

The filter element consists of star-shaped, pleated filter material, which is supported on the inside by a perforated core tube and is bonded to the end caps with a high-quality adhesive. The flow direction is from outside to inside.

For cleaning the stainless steel mesh element (see special leaflets 21070-4 and 39448-4) or changing the filter element, remove the cover and take out the element. The mesh elements are not guaranteed to maintain 100% performance after cleaning.

For filtration finer than 40 µm, use the disposable elements made of microglass. Filter elements as fine as 5 µm(c) are available; finer filter elements are available upon request.

Eaton filter elements are known for a high intrinsic stability and an excellent filtration capability, a high dirt-retaining capacity and a long service life.

Eaton filter can be used for petroleum-based fluids, HW emulsions, water glycols, most synthetic fluids and lubrication fluids. Consult factory for specific fluid applications.

Ship classifications available upon request.

Type index:

Complete filter: (ordering example)

LF. 401. 10VG. 30. E. P. -. FS. 8. -. -. -. AE

1	2	3	4	5	6	7	8	9	10	11	12	13
---	---	---	---	---	---	---	---	---	----	----	----	----

- 1 **series:**
LF = in-line filter
- 2 **nominal size:** 251, 401, 631
- 3 **filter-material:**
130G, 80G, 40G, 25G stainless steel wire mesh
25VG, 16VG, 10VG, 6VG, 3VG microglass
25API, 10API microglass according to API
- 4 **filter element collapse rating:**
30 = Δp 30 bar
- 5 **filter element design:**
E = single end open
S = with bypass valve Δp 2,0 bar
S1 = with bypass valve Δp 3,5 bar
- 6 **sealing material:**
P = Nitrile (NBR)
V = Viton (FPM)
- 7 **filter element specification:**
- = standard
VA = stainless steel
IS06 = for HFC application, see sheet-no. 31601
- 8 **process connection:**
FS = SAE-flange connection 3000 PSI
- 9 **process connection size:**
7 = 1 ½" (LF 251)
8 = 2" (LF 401)
9 = 2 ½" (LF 631)
- 10 **filter housing specification:**
- = standard
- 11 **pressure vessel specification:**
- = standard (PED 2014/68/EU)
IS20 = ASME VIII Div.1 with ASME equivalent material, see sheet-no. 55217 (max. operating pressure 16 bar)
- 12 **internal valve:**
- = without
- 13 **clogging indicator or clogging sensor:**
- = without
AOR = visual, see sheet-no.1606
AOC = visual, see sheet-no.1606
AE = visual-electric, see sheet-no.1609
OP = visual, see sheet-no.1628
OE = visual-electric, see sheet-no.1628
VS5 = electronic, see sheet-no.1641

To add an indicator/sensor to your filter, use the corresponding indicator data sheet to find the indicator details and add them to the filter assembly model code.

Filter element: (ordering example)

01NL. 400. 10VG. 30. E. P. -

1	2	3	4	5	6	7
---	---	---	---	---	---	---

- 1 **series:**
01NL = standard filter element according to DIN 24550, T3
- 2 **nominal size:** 250, 400, 630
- 3 - 7 see type index complete filter

Accessories:

- gauge port and bleeder connection, see sheet-no. 1650
- drain- and bleeder connection, see sheet-no. 1651
- SAE-counter flanges, see sheet-no. 1652

Technical data:

operating temperature:	-10 °C to +100 °C
operating medium:	mineral oil, other media on request
max. operating pressure:	32 bar
test pressure:	64 bar
max. operating pressure with IS20:	16 bar
test pressure with IS20:	32 bar
process connection:	SAE-flange connection 3000 PSI
housing material:	EN-GJS-400-18-LT
sealing material:	Nitrile (NBR) or Viton (FPM), other materials on request
installation position:	vertical
measuring connections:	G ¼
drain- and bleeder connections:	G ½
volume tank LF 251:	2,4 l
LF 401:	3,6 l
LF 631:	5,3 l

Classified under the Pressure Equipment Directive 2014/68/EU for mineral oil (fluid group 2), Article 4, Para. 3.
Classified under ATEX Directive 2014/34/EU according to specific application (see questionnaire sheet-no. 34279-4).

Pressure drop flow curves:

Filter calculation/sizing

The pressure drop of the assembly at a given flow rate Q is the sum of the housing Δp and the element Δp and is calculated as follows:

$$\Delta p_{assembly} = \Delta p_{housing} + \Delta p_{element}$$

$$\Delta p_{housing} = (\text{see } \Delta p = f(Q) \text{ - characteristics})$$

$$\Delta p_{Element} (mbar) = Q \left(\frac{l}{min} \right) \times \frac{MSK (mbar)}{10 \left(\frac{l}{min} \right)} \times v \left(\frac{mm^2}{s} \right) \times \frac{p}{0,876} \left(\frac{kg}{dm^3} \right)$$

For ease of calculation our Filter Selection tool is available online at

www.eatonpowersource.com/calculators/filtration/

Material gradient coefficients (MSK) for filter elements

The material gradient coefficients in mbar/(l/min) apply to mineral oil (HLP) with a density of 0,876 kg/dm³ and a kinematic viscosity of 30 mm²/s (139 SUS). The pressure drop changes proportionally to the change in kinematic viscosity and density.

LF	VG					G				API	
	3VG	6VG	10VG	16VG	25VG	25G	40G	80G	130G	10API	25API
251	0,931	0,646	0,414	0,360	0,246	0,0277	0,0258	0,0177	0,0131	0,212	0,097
401	0,571	0,397	0,254	0,221	0,151	0,0169	0,0158	0,0108	0,0080	0,130	0,059
631	0,436	0,303	0,194	0,169	0,115	0,0142	0,0132	0,0091	0,0067	0,099	0,045

$\Delta p = f(Q)$ – characteristics according to ISO 3968

The pressure drop characteristics apply to mineral oil (HLP) with a density of 0,876 kg/dm³. The pressure drop changes proportionally to the density.

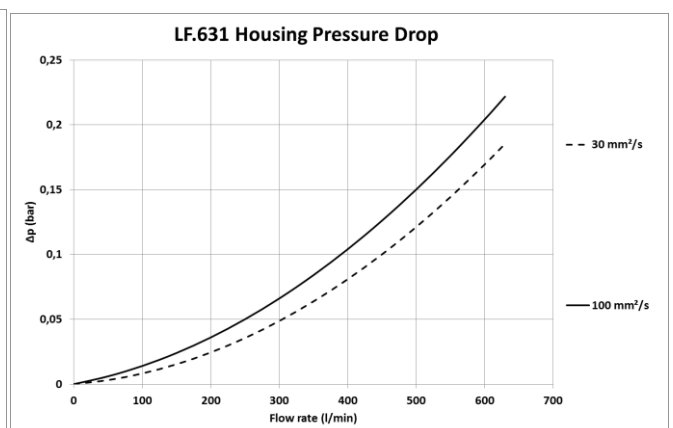
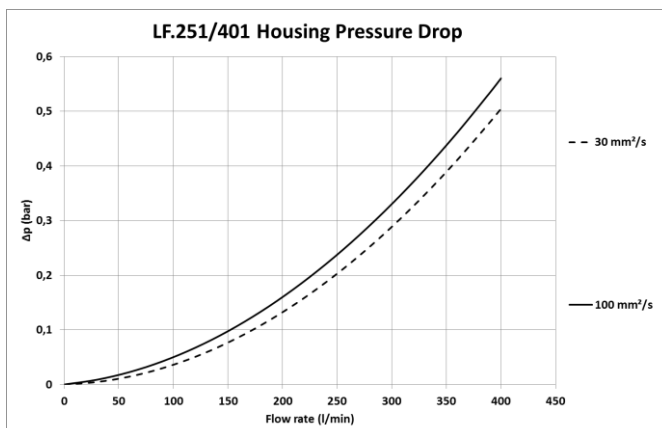

Symbols:

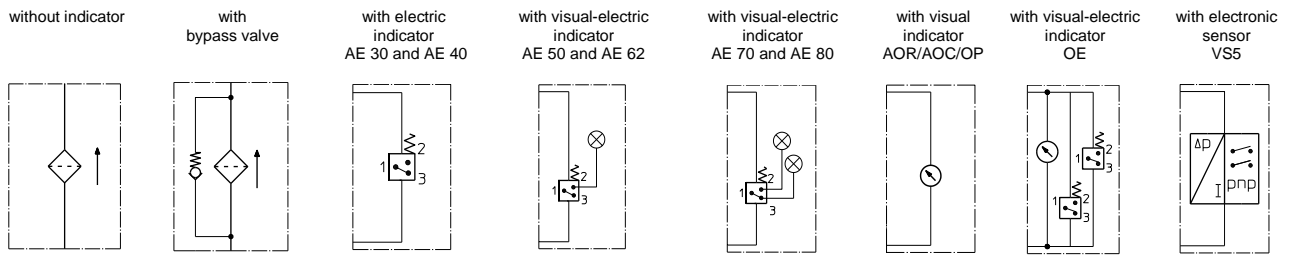

Spare parts:

item	designation	qty.	dimension and article no. LF 251	qty.	dimension and article no. LF 401	qty.	dimension and article no. LF 631
1	filter element	1	01NL.250...	1	01NL.400...	1	01NL.630...
2	O-ring	1	40 x 3 304389 (NBR) 304391 (FPM)	1	40 x 3 304389 (NBR) 304391 (FPM)	1	60 x 3,5 304377 (NBR) 304398 (FPM)
3	O-ring	1	115 x 3 303963 (NBR) 307762 (FPM)	1	115 x 3 303963 (NBR) 307762 (FPM)	1	125 x 3 306025 (NBR) 307358 (FPM)
4	O-ring (LF 401/631)	-	-	1	56,75 x 3,53 306035 (NBR) 310264 (FPM)	1	69,45 x 3,53 305868 (NBR) 307357 (FPM)
5	screw plug	3	G ½ 304678	3	G ½ 304678	3	G ½ 304678
6	screw plug	2	G ¼ 305003				
7	clogging indicator, visual		AOR or AOC see sheet no. 1606				
8	clogging indicator, visual	1	OP see sheet no. 1628				
9	clogging indicator, visual-electric	1	OE see sheet no. 1628				
10	clogging indicator, visual-electric	1	AE see sheet no. 1609				
11	clogging indicator, electronic	1	VS 5 see sheet no. 1641				
12	screw plug	2	G ¼ 305003				

item 12 execution only without clogging indicator or clogging sensor

Test methods:

Filter elements are tested according to the following ISO standards:

ISO 2941	Verification of collapse/burst resistance
ISO 2942	Verification of fabrication integrity
ISO 2943	Verification of material compatibility with fluids
ISO 3723	Method for end load test
ISO 3724	Verification of flow fatigue characteristics
ISO 3968	Evaluation of pressure drop versus flow characteristics
ISO 16889	Multi-pass method for evaluating filtration performance