

Series MDD 40-63

DN15-20 PN200

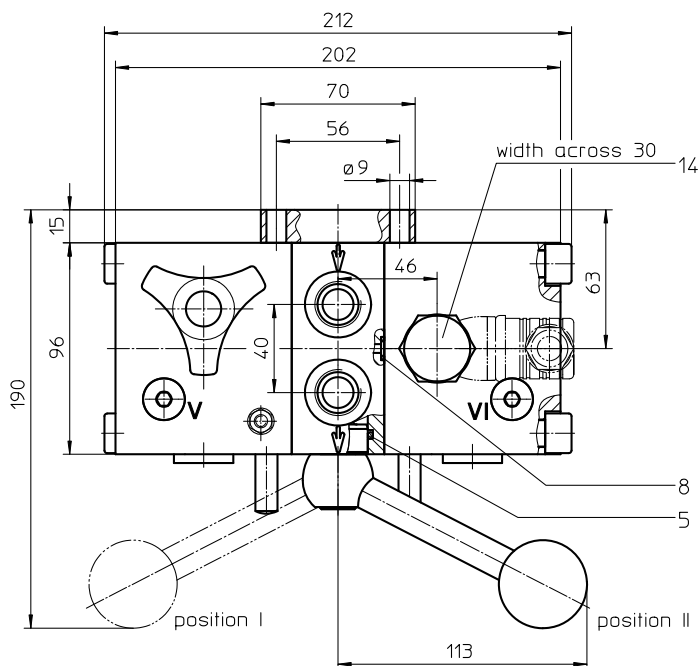
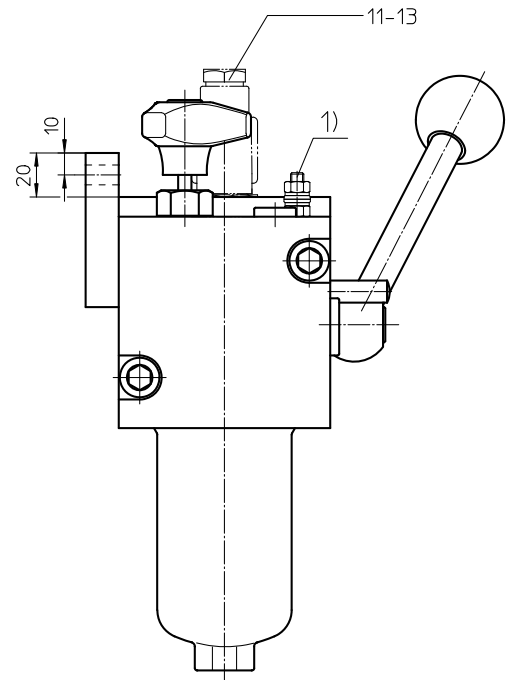
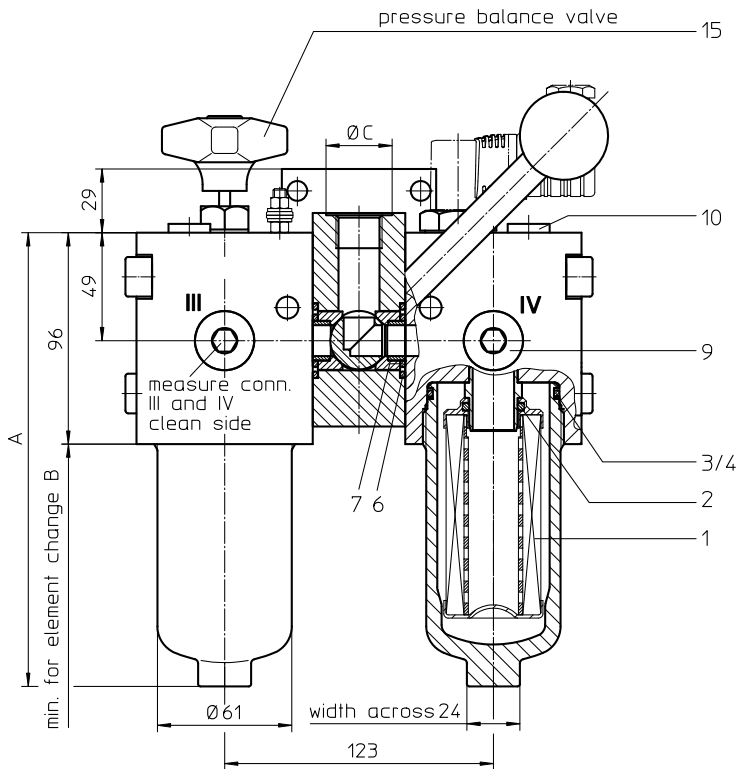

Dimensions:

type	MDD 40	MDD 63
connection	G 1/2	G 3/4
A	206	266
B	285	345
C	30	36,5
weight kg	16	17
volume tank	2x 0,25 l	2x 0,35 l

1) Connection for the potential equalization, only for application in the explosive area.

Measure connections III and IV to be used for pressure relief and air bleeding respective filter side.

Position I: left filter side in operation
Position II: right filter side in operation

Dimensions: mm

Designs and performance values are subject to change.

EDV 07/19

Pressure Filter, change over Series MDD 40-63 DN15-20 PN200

Description:

Pressure filters change over series MDD 40-63 are suitable for operating pressure up to 200 bar. The pressure peaks are absorbed by a sufficient margin of safety.

Duplex filters can be maintained without interruption. The upper part has a three-way-change-over valve which allows to change-over the flow from the dirty filter-side to the clean filter-side without interrupting the operation. The change-over procedure does not lead to a cross sectional contraction. Prior to the change-over procedure a built-in pressure balance valve equalizes the housing pressure. After change-over the pressure balance valve has to be closed again. The closed filter-side has to be air-bled by vent V respectively by vent VI. Then change filter element. After screw in the filter bowl the pressure balance has to be opened shortly and the just serviced filter-side has to be air-bled. Filter elements are available down to a filter fineness of 5 µm(c).

Eaton filter elements are known for high intrinsic stability and an excellent filtration capability, a high dirt-retaining capacity and a long service life.

Eaton filter elements are available up to a pressure resistance of Δp 160 bar and a rupture strength of Δp 250 bar.

The internal valve is integrated into the filter head. After reaching the bypass pressure setting, the bypass valve will send unfiltered partial flow around the filter.

The reversing valve provides another level of protection for the filter element. The reverse flow will not be filtered.

Eaton filter can be used for petroleum-based fluids, HW emulsions, water glycols, most synthetic fluids and lubrication fluids. Consult factory for specific fluid applications.

Type index:

Complete filter: (ordering example)

MDD.	40.	10VG.	HR.	E.	P.	-.	G.	3.	-.	-.	AE
1	2	3	4	5	6	7	8	9	10	11	12

- 1 series:**
MDD = medium pressure filter, change over
- 2 nominal size:** 40, 63
- 3 filter material:**
25VG, 16VG, 10VG, 6VG, 3VG microglass
- 4 filter element collapse rating:**
30 = Δp 30 bar
HR = Δp 160 bar (rupture strength Δp 250 bar)
- 5 filter element design:**
E = single-end open
- 6 sealing material:**
P = Nitrile (NBR)
V = Viton (FPM)
- 7 filter element specification:**
- = standard
VA = stainless steel
IS06 = for HFC applications, see sheet-no. 31601
- 8 process connection:**
G = thread connection according to ISO 228
- 9 process connection size:**
3 = G ½ (MDD 40)
4 = G ¾ (MDD 63)
- 10 filter housing specification:**
- = standard
IS06 = for HFC applications, see sheet-no. 31605
IS12 = internal parts of change over armature stainless steel, see sheet-n. 41028
- 11 internal valve:**
- = without
S1 = with by-pass valve Δp 3,5 bar
S2 = with by-pass valve Δp 7,0 bar
R = with reversing valve, Q ≤ 70,06 l/min
- 12 clogging indicator or clogging sensor:**
- = without
AOR = visual, see sheet-no. 1606
AOC = visual, see sheet-no. 1606
AE = visual-electric, see sheet-no. 1615
VS5 = electronic, see sheet-no. 1619

To add an indicator/sensor to your filter, use the corresponding indicator data sheet to find the indicator details and add them to the filter assembly model code

Filter element: (ordering example)

01NL.	40.	10VG.	HR.	E.	P.	-
1	2	3	4	5	6	7

- 1 series:**
01NL = standard filter element according to DIN 24550, T3
- 2 nominal size:** 40, 63
- 3 - 7** see type index-complete filter

Accessories:

- gauge port- and bleeder connections, see sheet-no. 1650

For more information:

WEB: FLTR.com.au PHONE: (+61) 1300 62 4020 EMAIL: info@FLTR.com.au SKYPE: Purple.Engineering



Technical data:

operating temperature:	-10 °C to +100 °C
operating medium:	mineral oil, other media on request
max. operating pressure:	200 bar
test pressure:	286 bar
process connection:	thread connection according to ISO 228
housing material:	C-steel
sealing material:	Nitrile (NBR) or Viton (FPM), other materials on request
installation position:	vertical
bleeder- and measuring connections dirt side:	G ¼
measuring connections clean side:	G ½

Classified under the Pressure Equipment Directive 2014/68/EU for mineral oil (fluid group 2), Article 4, Para. 3.
Classified under ATEX Directive 2014/34/EU according to specific application (see questionnaire sheet-no. 34279-4).

Pressure drop flow curves:

Filter calculation/sizing

The pressure drop of the assembly at a given flow rate Q is the sum of the housing Δp and the element Δp and is calculated as follows:

$$\Delta p_{assembly} = \Delta p_{housing} + \Delta p_{element}$$

$$\Delta p_{housing} = (\text{see } \Delta p = f(Q) \text{ - characteristics})$$

$$\Delta p_{Element} (mbar) = Q \left(\frac{l}{min} \right) \times \frac{MSK (mbar)}{10 \left(\frac{l}{min} \right)} \times v \left(\frac{mm^2}{s} \right) \times \frac{p}{0,876} \left(\frac{kg}{dm^3} \right)$$

For ease of calculation our Filter Selection tool is available online at

www.eatonpowersource.com/calculators/filtration/

Material gradient coefficients (MSK) for filter elements

The material gradient coefficients in mbar/(l/min) apply to mineral oil (HLP) with a density of 0,876 kg/dm³ and a kinematic viscosity of 30 mm²/s (139 SUS). The pressure drop changes proportionally to the change in kinematic viscosity and density.

MDD	VG				
	3VG	6VG	10VG	16VG	25VG
40	5,709	3,963	2,537	2,209	1,509
63	3,441	2,389	1,530	1,332	0,910

$\Delta p = f(Q)$ – characteristics according to ISO 3968

The pressure drop characteristics apply to mineral oil (HLP) with a density of 0,876 kg/dm³. The pressure drop changes proportionally to the density.

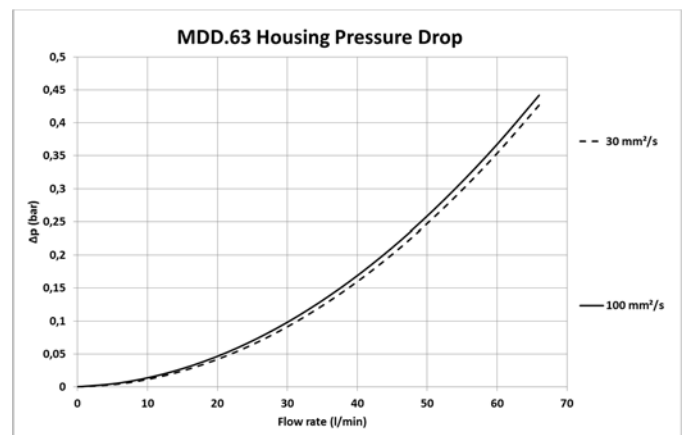
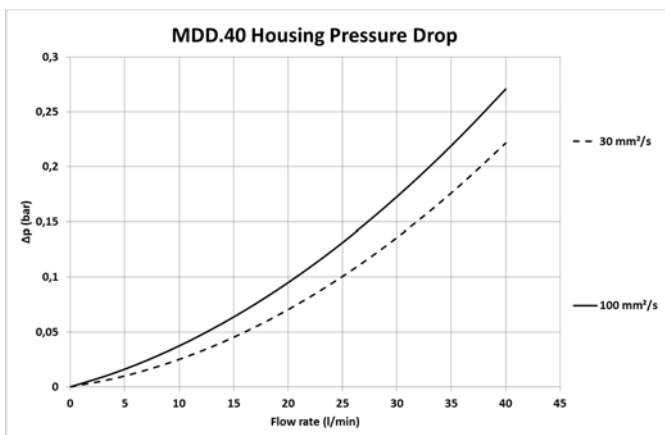

For more information:

WEB: FLTR.com.au PHONE: (+61) 1300 62 4020 EMAIL: info@FLTR.com.au SKYPE: Purple.Engineering

Symbols:

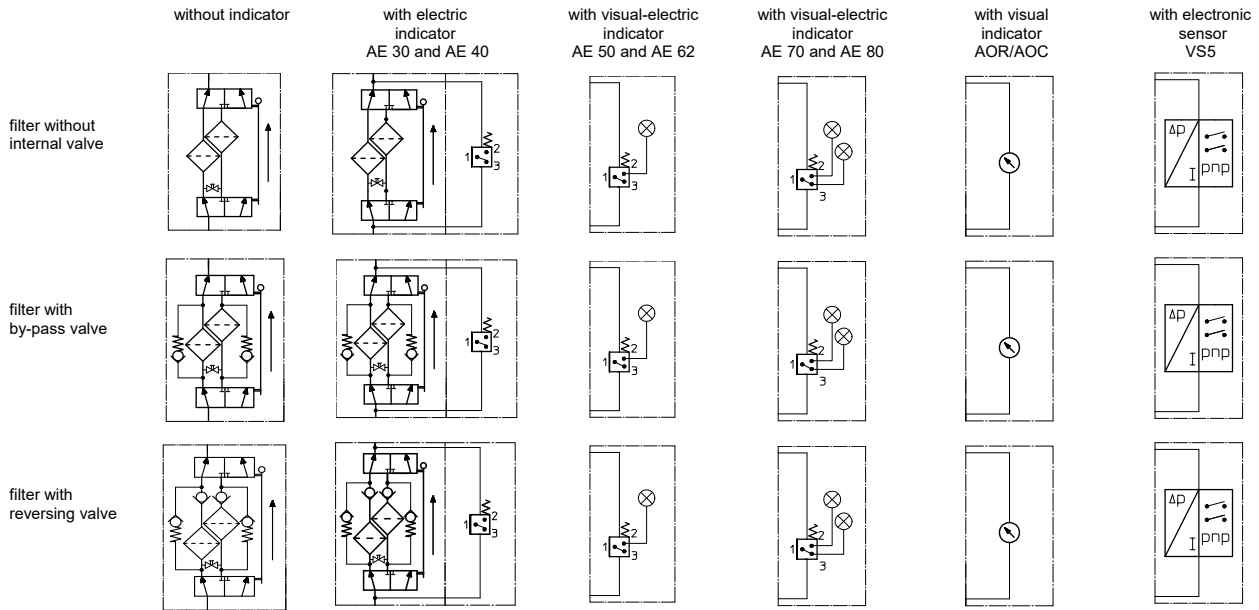

Spare parts:

item	qty.	designation	dimension		article-no.	
			MDD 40 01NL.40...	MDD 63 01NL.63...		
1	2	filter element				
2	2	O-ring	22 x 3,5		304341 (NBR)	304392 (FPM)
3	2	O-ring	54 x 3		304657 (NBR)	304720 (FPM)
4	2	support ring	60 x 2,6 x 1		311779	
5	3	O-ring	26 x 3		304359 (NBR)	304399 (FPM)
6	4	O-ring	28 x 3		316778 (NBR)	318366 (FPM)
7	4	O-ring	18 x 3		304359 (NBR)	304399 (FPM)
8	4	O-ring	6,5 x 2		313553 (NBR)	318577 (FPM)
9	2	screw plug	G 1/2		304678	
10	2	screw plug	G 1/4		305003	
11	1	clogging indicator, visual	AOR or AOC		see sheet-no. 1606	
12	1	clogging indicator, visual-electric	AE		see sheet-no. 1615	
13	1	clogging sensor, electronic	VS5		see sheet-no. 1619	
14	1	screw plug	20913-4		309817	
15	1	pressure balance valve	DN10		305000	

item 14 execution only without clogging indicator or clogging sensor

Test methods:

Filter elements are tested according to the following ISO standards:

ISO 2941	Verification of collapse/burst resistance
ISO 2942	Verification of fabrication integrity
ISO 2943	Verification of material compatibility with fluids
ISO 3723	Method for end load test
ISO 3724	Verification of flow fatigue characteristics
ISO 3968	Evaluation of pressure drop versus flow characteristics
ISO 16889	Multi-pass method for evaluating filtration performance

For more information:

WEB: FLTR.com.au PHONE: (+61) 1300 62 4020 EMAIL: info@FLTR.com.au SKYPE: Purple.Engineering