

PRESSURE FILTER

Series MDV 40-63 DN 15 - 20 PN 200

Sheet No.
1419 E

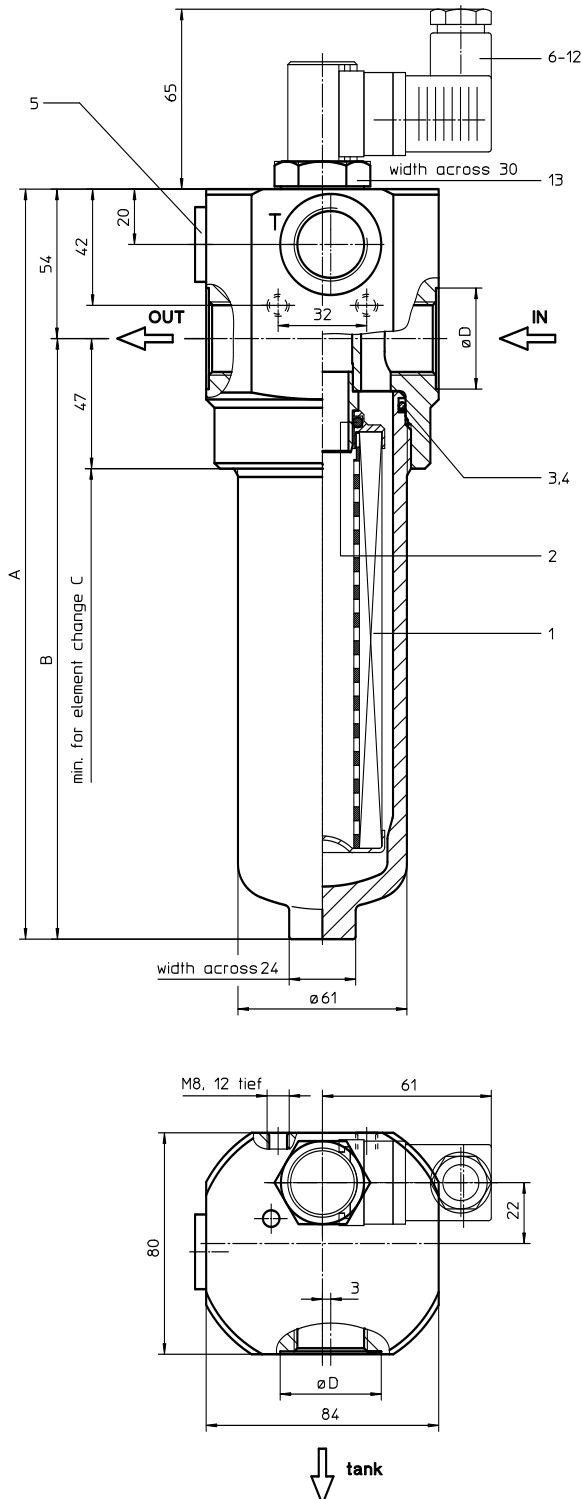

1. Type index:

1.1. Complete filter: (ordering example)

MDV.40.10VG.HR.E.P.-.G.3.-.D2.AE

1	2	3	4	5	6	7	8	9	10	11	12
---	---	---	---	---	---	---	---	---	----	----	----

- 1 **series:**
MDV = medium pressure filter with differential pressure-valve
- 2 **nominal size:** 40, 63
- 3 **filter-material and filter-fineness:**
80 G = 80 μm , 40 G = 40 μm , 25 G = 25 μm
stainless steel wire mesh
25 VG = 20 $\mu\text{m}_{(c)}$, 16 VG = 15 $\mu\text{m}_{(c)}$, 10 VG = 10 $\mu\text{m}_{(c)}$,
6 VG = 7 $\mu\text{m}_{(c)}$, 3 VG = 5 $\mu\text{m}_{(c)}$ Interpor fleece (glass fibre)
- 4 **resistance of pressure difference for filter element:**
30 = Δp 30 bar
HR = Δp 160 bar (rupture strength Δp 250 bar)
- 5 **filter element design:**
E = single-end open
- 6 **sealing material:**
P = Nitrile (NBR)
V = Viton (FPM)
- 7 **filter element specification:**
- = standard
VA = stainless steel
- 8 **connection:**
G = thread connection according to ISO 228
- 9 **connection size:**
3 = G 1/2
4 = G 3/4
- 10 **filter housing specification:**
- = standard
- 11 **internal valve:**
D1 = differential pressure-valve Δp 3,5 bar
D2 = differential pressure-valve Δp 7,0 bar
- 12 **clogging indicator or clogging sensor:**
- = without
AOR = visual, see sheet-no. 1606
AOC = visual, see sheet-no. 1606
AE = visual-electrical, see sheet-no. 1615
VS1 = electronical, see sheet-no. 1617
VS2 = electronical, see sheet-no. 1618

1.2. Filter element: (ordering example)

01NL.40.10VG.HR.E.P.-

1	2	3	4	5	6	7
---	---	---	---	---	---	---

- 1 **series:**
01NL = standard filter element according to DIN 24550, T3
- 2 **nominal size:** 40, 63
- 3 - 7 see type index-complete filter

2. Dimensions:

type	connection	A	B	C	D	weight kg	volume tank
MDV 40	G 1/2	211	157	265	30	2,7	0,25 l
MDV 63	G 3/4	271	217	325	36,5	3,2	0,35 l

Connection assignments as shown in the table are standard according to DIN 24 550 T1.

Are the connection assignments against DIN 24 550 T1, see item 9 of the type code.

3. Spare parts:

item	qty.	designation	dimension		article-no.	
			MDV 40 01NL.40	MDV 63 01NL.63		
1	1	filter element				
2	1	O-ring		22 x 3,5	304341 (NBR)	304392 (FPM)
3	1	O-ring		54 x 3	304657 (NBR)	304720 (FPM)
4	1	support ring		60 x 2,6 x 1	311779	
5	1	screw plug		G ½	304678	
6	1	clogging indicator visual		AOR or AOC	see sheet-no. 1606	
7	1	clogging indicator visual-electrical		AE	see sheet-no. 1615	
8	1	clogging sensor electrical		VS1	see sheet-no. 1617	
9	1	clogging sensor electrical		VS2	see sheet-no. 1618	
10	1	O-ring		15 x 1,5	315357 (NBR)	315427 (FPM)
11	1	O-ring		22 x 2	304708 (NBR)	304721 (FPM)
12	1	O-ring		14 x 2	304342 (NBR)	304722 (FPM)
13	1	screw plug		20913-4	309817	

item 13 execution only without clogging indicator or clogging sensor

4. Description:

The pressure filters of the series MDV are suitable for a working pressure up to 200 bar and equipped with elements according to DIN 24 550 T3.

The pressure peaks are absorbed by a sufficient margin of safety. The MDV-filter is in-line mounted.

The filter element consists of star-shaped, pleated filter material which is supported on the inside by a perforated core tube and is bonded to the end caps with a high-quality adhesive. The flow direction is from outside to the inside. Filter elements are available down to 4µm_(c).

Internormen Product Line filter elements are known as elements with a high intrinsic stability and an excellent filtration capability, a high dirt-retaining capacity and a long service life.

Internormen Product Line filter are suitable for all petroleum based fluids, HW-emulsions, most synthetic hydraulic fluids and lubrication oils.

Internormen Product Line filter elements are available up to a pressure difference resistance of Δp 160 bar and a rupture strength of Δp 250 bar.

The differential pressure-valve opens independently of the operating pressure at a chosen differential pressure-valve between IN and OUT and leaves an unfiltered partial-flow flowing from „IN“ to the tank.

5. Technical data:

temperature range:	- 10°C to + 80°C (for a short time + 100°C)
operating medium:	mineral oil, other media on request
max. operating pressure:	200 bar
test pressure:	286 bar
connection system:	thread connection according to ISO 228
housing material:	aluminium forging alloy; C-steel
sealing material:	Nitrile (NBR) or Viton (FPM), other materials on request
installation position:	vertical

Classified under the Pressure Equipment Directive 97/23/EC for mineral oil (fluid group 2), Article 3, Para. 3.

Classified under ATEX Directive 94/9/EC according to specific application (see questionnaire sheet-no. 34279-4).

6. Symbols:

without indicator

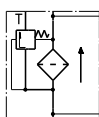

with electrical indicator
AE 30 and AE 40

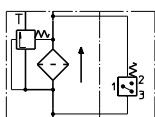

with visual-electrical indicator
AE 50 and AE 62

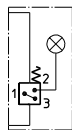

with visual-electrical indicator
AE 70 and AE 80

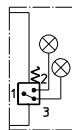

with visual indicator
AOR/AOC

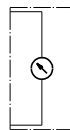

with electrical clogging sensor
VS1

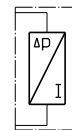

with electrical clogging sensor
VS2

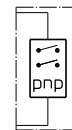

7. Pressure drop flow curves:

Precise flow rates see 'Interactive Product Specifier' respectively Δp-curves ; depending on filter fineness and viscosity.

8. Test methods:

Filter elements are tested according to the following ISO standards:

ISO 2941	Verification of collapse/burst resistance
ISO 2942	Verification of fabrication integrity
ISO 2943	Verification of material compatibility with fluids
ISO 3723	Method for end load test
ISO 3724	Verification of flow fatigue characteristics
ISO 3968	Evaluation of pressure drop versus flow characteristics
ISO 16889	Multi-pass method for evaluating filtration performance