

1. Type index:

1.1. Complete filter: (ordering example)

MNU.255.10VG.30.E.P.-.P.6.-.-.AE

1	2	3	4	5	6	7	8	9	10	11	12
---	---	---	---	---	---	---	---	---	----	----	----

- 1 **series:**
MNU = medium pressure standard filter for manifold mounted
- 2 **nominal size:** 255
- 3 **filter-fineness and filter-material:**
80 G = 80 μm , 40 G = 40 μm , 25 G = 25 μm stainless steel wire mesh
25 VG = 20 $\mu\text{m}_{(c)}$, 16 VG = 15 $\mu\text{m}_{(c)}$, 10 VG = 10 $\mu\text{m}_{(c)}$,
6 VG = 7 $\mu\text{m}_{(c)}$, 3 VG = 5 $\mu\text{m}_{(c)}$ Interpor fleece (glass fibre)
- 4 **resistance of pressure difference:**
30 = filter element for Δp 30 bar
HR = filter element for Δp 160 bar (rupture strength Δp 250 bar)
- 5 **filter element design:**
E = single-end open
- 6 **sealing material:**
P = Nitrile (NBR)
V = Viton (FPM)
- 7 **filter element specification:**
- = standard
VA = stainless steel
- 8 **connection:**
P = manifold mounted
- 9 **connection size:**
6 = DN 32
- 10 **filter housing specification:**
- = standard
- 11 **internal valve:**
- = without
S1 = with by-pass valve Δp 3,5 bar
S2 = with by-pass valve Δp 7,0 bar
- 12 **clogging indicator or clogging sensor:**
- = without
AE = visual-electrical, see sheet-no. 1609
VS1 = electrical, see sheet-no. 1607
VS2 = electrical, see sheet-no. 1608

1.2. Filter element: (ordering example)

01NL.250.10VG.30.E.P.-

1	2	3	4	5	6	7
---	---	---	---	---	---	---

- 1 **series:**
01NL. = standard filter element according to DIN 24 550, T3
- 2 **nominal size:** 250
- 3 - 7 | see type index-complete filter

weight: approx. 28 kg

Changes of measures and design are subject to alteration!

2. Spare parts:

item	qty.	designation	dimension	article-no.	
1	1	filter element	01NL. 250		
2	1	O-ring	40 x 3	304389 (NBR)	304391 (FPM)
3	1	O-ring	98 x 4	301914 (NBR)	304765 (FPM)
4	1	support ring	107 x 3,5 x 1,5	317663	
5	2	O-ring	36 x 3	304358 (NBR)	313900 (FPM)
6	1	clogging indicator,visual-electrical	AE	see sheet-no. 1609	
7	1	clogging sensor,electronical	VS1	see sheet-no. 1607	
8	1	clogging sensor,electronical	VS2	see sheet-no. 1608	
9	2	O-ring	14 x 2	304342 (NBR)	304722 (FPM)
10	2	screw plug	G 1/8	304791	
11	2	screw plug	G 1/2	304678	

item 10 execution only without clogging indicator or clogging sensor

3. Description:

Pressure filters of the series MNU 255 are suitable for a working pressure up to 250 bar and equipped with filter elements according to DIN 24550, T3. The pressure peaks are absorbed by a sufficient margin of safety. The MNU-filters are flange-mounted to the hydraulic system.

The filter element consists of star-shaped, pleated filter material which is supported on the inside by a perforated core tube and is bonded to the end caps with a high-quality adhesive.

The flow direction is from outside to the inside. Filter elements are available down to 4 $\mu\text{m}_{(C)}$.

Internormen Product Line filter elements are known as elements with a high intrinsic stability and an excellent filtration capability, a high dirt-retaining capacity and a long service life.

Internormen Product Line filter are suitable for all petroleum based fluids, HW-emulsions, most synthetic hydraulic fluids and lubrication oils. Internormen Product Line filter elements are available up to a pressure difference resistance of Δp 160 bar and a rupture strength of Δp 250 bar.

The internal valves are integrated into the centering pivot for the filter element.

After reaching the opening pressure the by-pass valve causes that an unfiltered partial flow passes the filter.

4. Technical data:

temperature range:	-10°C to +80°C (for a short time +100°C)
operating medium:	mineral oil, other media on request
max. operating pressure:	250 bar
test pressure:	358 bar
connection system:	manifold mounted
housing material:	C-steel / tempering steel
sealing material:	Nitrile (NBR) or Viton (FPM), other materials on request
installation position:	vertical
volume tank:	1,6 l

Classified under the Pressure Equipment Directive 97/23/EC for mineral oil (fluid group 2), Article 3, Para. 3.

Classified under ATEX Directive 94/9/EC according to specific application (see questionnaire sheet-no. 34279-4).

6. Symbols:

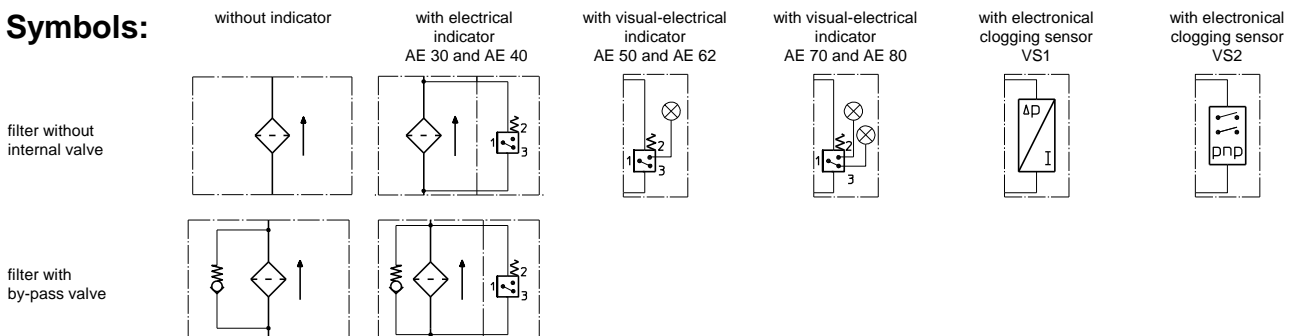

7. Pressure drop flow curves:

Precise flow rates see 'Interactive Product Specifier', respectively Δp -curves; depending on filter fineness and viscosity.

8. Test methods:

Filter elements are tested according to the following ISO standards:

ISO 2941	Verification of collapse/burst resistance
ISO 2942	Verification of fabrication integrity
ISO 2943	Verification of material compatibility with fluids
ISO 3723	Method for end load test
ISO 3724	Verification of flow fatigue characteristics
ISO 3968	Evaluation of pressure drop versus flow characteristics
ISO 16889	Multi-pass method for evaluating filtration performance

E 1418 C

For more information:

WEB: FLTR.com.au PHONE: (+61) 1300 62 4020 EMAIL: info@FLTR.com.au SKYPE: Purple.Engineering

