

Model 91



Quick opening spin off cover with davit assembly

- Carbon steel or stainless steel*
- Sizes 2" to 48"
- Flanged or butt weld

Features

- ANSI class 150, 300, 600 or DIN EN flanges
- Vertical or horizontal orientation
- Low pressure drop
- Convoluted screen for more surface area with perforations from 1/16" to 1/2"
- 20 to 60 mesh linings for fine straining applications

Options

- Quick open hinged or davit cover assembly bolted cover
- Alloy construction for body and baskets
- Construction according to "AD 2000-Merkblätter", DIN EN 13445 or ASME Code
- Steam jacket for highly viscous fluids
- Straight through or right angle configuration
- Flanged class 600 or butt weld piping connections

Customize to improve performance and meet higher pressure requirements

The Eaton Model 91 fabricated T strainer, typically used for pump protection or other low solids applications has several advantages over other strainer designs. Its compact design is perfect for applications with restricted space, either vertical or horizontal installations are possible, and when cleaning the strainer, draining the vessel is not necessary. It also can be adapted for straight through or right angle flow, making it ideal for retrofit situations.

Cover type openings

For applications with infrequent basket changing, Eaton offers a simple, cost-effective, bolted cover type. It's available with a davit assembly cover for larger strainers with heavy covers, this makes it possible for a one-person operation.

For applications with more frequent changing, Eaton offers a hinged, quick opening cover secured by swing bolts. This is adaptable for higher pressure applications. For medium size strainers, 14" to 16," a davit assembly bolted cover is available. This permits one operator to open the cover.

Strainer design

The convoluted design of the strainer screen doubles the screen area and completely changes the dirt accumulation pattern on the screen, more effectively using the screen's straining area and increasing the time between cleanings. The combination of a convoluted strainer screen and unrestricted flow path results in a very low pressure drop, ideal for applications such as condensate and boiler feed pump suction.

Strainer screens

Strainer screens are stainless steel or other specified materials.

Optional steam jacketing

Available in carbon steel or stainless steel rated for service up to 232 °C. This is ideal for the high temperatures required to process and transport heavy, viscous fluids without affecting the function or normal maintenance of the strainer. Steam jacketing maintains critical fluid temperature throughout the strainer.

Eaton customizes the strainers to meet special application requirements. Design and fabrication to "AD 2000-Merkblätter", DIN EN 13445 or ASME Code and ANSI B31.1 are available.



Model 91 with hinged cover

* Stainless steel strainers include carbon steel, external, non-wetted fasteners as standard.

Model 91 Fabricated T-Type Strainer

Dimensions are for reference only. For installation purposes, contact Eaton for certified drawings.

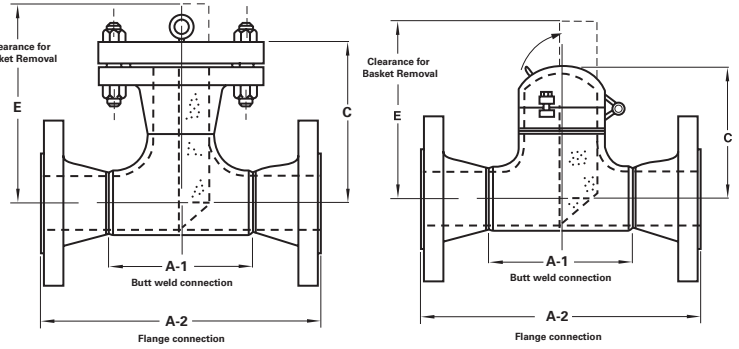
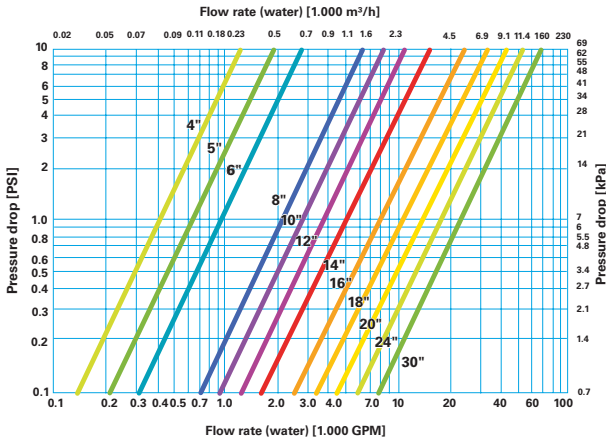

*Force required to lift cover in lb.

Model 91 with bolted cover

Nom size	Dimensions (in / mm)										Weight (kg)			
	Butt weld connections Class 150		Butt weld connections Class 300		Flanged connections Class 150		Flanged connections Class 300		E	Class 150		Class 300		
	A-1	C	A-1	C	A-2	C	A-2	C		Cover	Unit	Cover	Unit	
2	5 / 127	5-1/4 / 133	5 / 127	6-1/8 / 156	10 / 254	5-3/4 / 146	10-1/2 / 267	6-1/8 / 156	13 / 330	1.8	11.3	3.6	17.2	
3	6-3/4 / 171	7-1/8 / 181	6-3/4 / 171	7-5/8 / 194	12-1/4 / 311	7-1/8 / 181	13 / 330	7-5/8 / 194	14 / 356	4.1	22.7	7.3	31.3	
4	8-1/4 / 210	8-1/8 / 206	8-1/4 / 210	8-3/4 / 222	14-1/4 / 362	8-1/8 / 206	15 / 381	8-3/4 / 222	16 / 406	7.7	34.0	12.2	52.2	
5	9-3/4 / 248	9-3/8 / 238	9-3/4 / 248	10-1/8 / 257	16-3/4 / 425	9-3/8 / 238	17-1/2 / 445	10-1/8 / 257	19 / 483	9.1	36.3	15.9	68.5	
6	11-1/4 / 286	10-1/8 / 257	11-1/4 / 286	11 / 279	18-1/4 / 464	10-1/8 / 257	19 / 483	11 / 279	22 / 559	11.8	49.9	22.7	93.4	
8	14 / 356	12-1/8 / 308	14 / 356	13 / 330	22 / 559	12-1/8 / 308	22-3/4 / 578	13 / 330	25 / 635	20.4	83.9	36.7	152.4	
10	17 / 432	13-3/4 / 349	17 / 432	15 / 381	25 / 635	13-3/4 / 349	26-1/4 / 667	15 / 381	29 / 737	31.8	147.0	57.6	222.7	
12	20 / 508	15-3/4 / 400	20 / 508	17-1/8 / 435	29 / 737	15-3/4 / 400	30-1/4 / 768	17-1/8 / 435	31 / 787	49.9	186.0	83.5	331.1	
14	22 / 559	17-3/8 / 441	22 / 559	18-3/4 / 476	32 / 813	17-3/8 / 441	33-1/4 / 845	18-3/4 / 476	38 / 965	59.4	279.0	107.0	438.2	
16	24 / 610	18-1/2 / 470	24 / 610	20 / 508	34 / 864	18-1/2 / 470	35-1/2 / 902	20 / 508	41 / 1041	77.1	352.0	139.3	573.4	
18	27 / 686	20-5/8 / 524	27 / 686	22-1/8 / 562	38 / 965	20-5/8 / 524	39-1/2 / 1003	22-1/8 / 562	46 / 1168	94.8	417.3	176.9	719.9	
20	30 / 762	22-3/8 / 568	30 / 762	23-7/8 / 606	41-3/8 / 1051	22-3/8 / 568	42-3/4 / 1086	23-7/8 / 606	51 / 1295	123.4	535.2	223.2	898.1	
24	34 / 864	24-7/8 / 632	34 / 864	26-3/8 / 670	46 / 1168	24-7/8 / 632	47-1/4 / 1200	26-3/8 / 670	56 / 1422	186.4	933.4	269.4	1,234.7	

Model 91 with quick open hinge cover

Nom size	Dimensions (in / mm)										Weight (kg)			
	Butt weld connections Class 150		Butt weld connections Class 300		Flanged connections Class 150		Flanged connections Class 300		E	Class 150		Class 300		
	A-1	C	A-1	C	A-2	C	A-2	C		Cover	Unit	Cover	Unit	
6	11-1/4 / 286	9-1/4 / 235	11-1/4 / 286	9-1/4 / 235	18-1/4 / 464	9-1/4 / 235	19 / 483	9-1/4 / 235	22 / 559	2.3	49.0	2.3	64.4	
8	14 / 356	11-1/8 / 283	14 / 356	11-1/8 / 283	22 / 559	11-1/8 / 283	22-3/4 / 578	11-1/8 / 283	25 / 635	4.1	70.8	4.1	94.3	
10	17 / 432	13-1/2 / 343	17 / 432	13-1/2 / 343	25 / 635	13-1/2 / 343	26-1/4 / 667	13-1/2 / 343	29 / 737	5.4	104.8	5.4	149.7	
12	20 / 508	15-5/8 / 397	20 / 508	15-5/8 / 397	29 / 737	15-5/8 / 397	30-1/4 / 768	15-5/8 / 397	31 / 787	6.8	55.1	6.8	207.7	
14	22 / 559	17-1/8 / 435	22 / 559	17-1/8 / 435	32 / 813	17-1/8 / 435	33-1/4 / 845	17-1/8 / 435	38 / 965	9.1	197.3	9.1	276.7	
16	24 / 610	18-5/8 / 473	24 / 610	18-5/8 / 473	34 / 864	18-5/8 / 473	35-1/2 / 902	18-5/8 / 473	41 / 1041	11.8	244.9	11.8	354.3	
18	27 / 686	21-1/8 / 537	27 / 686	21-1/8 / 537	38 / 965	21-1/8 / 537	39-1/2 / 1003	21-1/8 / 537	46 / 1168	14.5	299.4	14.5	449.1	
20	30 / 762	23-5/8 / 600	30 / 762	23-5/8 / 600	41-3/8 / 1051	23-5/8 / 600	42-3/4 / 1086	23-5/8 / 600	51 / 1295	18.1	365.6	18.1	554.3	
24	34 / 864	27-1/8 / 689	34 / 864	27-1/8 / 689	46 / 1168	27-1/8 / 689	47-1/4 / 1200	27-1/8 / 689	56 / 1422	26.3	492.2	26.3	796.1	

For more information:

WEB: FLTR.com.au PHONE: (+61) 1300 62 4020 EMAIL: info@FLTR.com.au SKYPE: Purple.Engineering

