

CLOGGING INDICATOR

Series OE (visual-electrical, block execution) explosion-proof

Sheet No.
1629 F

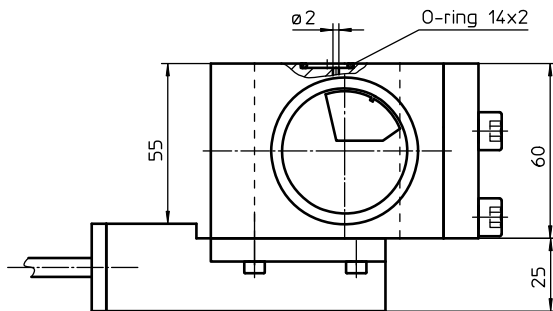
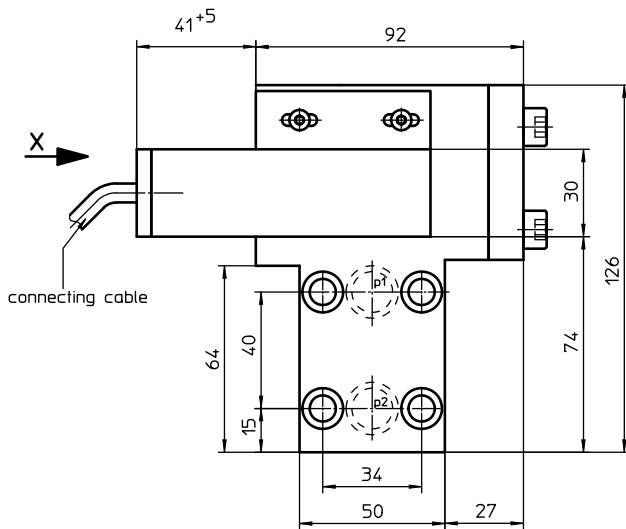

view X

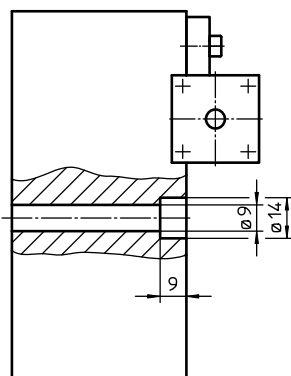

1. Type index: (ordering example)

OE. 1,2. B. -. P. VA. Ex

1	2	3	4	5	6	7
---	---	---	---	---	---	---

- 1 **series:**
OE = clogging indicator, visual-electrical with 1 contact maker with 70% switching pressure difference
- 2 **indicator-pressure difference:** Δp -nominal
0,8 = 0,8 bar
1,2 = 1,2 bar
2,5 = 2,5 bar
4,5 = 4,5 bar
- 3 **connection:**
B = block execution with flange connection
- 4 **connection size:**
- = standard
- 5 **sealing material:**
P = Nitrile (NBR)
V = Viton (FPM)
- 6 **material:**
VA = stainless steel
- 7 **execution:**
Ex = explosion-proof

2. Technical data:

permissible operating pressure:	63 bar
permissible fluid temperature:	
- Nitrile (NBR)	-25°C to +80°C
- Viton (FPM)	-10°C to +80°C
permissible ambient temperature:	-40°C to +60°C
permissible pressure difference:	$p_1 - p_2 \leq 16$ bar
indicator-pressure difference Δp :	0,8; 1,2; 2,5; 4,5 bar

The electrical signal takes place at 70% of the switching pressure difference.

3. Electrical data switching contact:

contact design:	reed contact - normally open
max. switching voltage:	200V DC 250V AC peak - peak
max. switching current:	1 A
max. breaking capacity:	30 Watt
type of protection:	Ex II 2 GD Ex mb II T6 KEMA 00ATEX 1112 X IP 65
certificated	
operating temperature range:	-40°C to +60°C
connecting cable:	HO5RN 2x 0,75 mm ²
length connecting cable:	max. 5 m

4. Symbol:

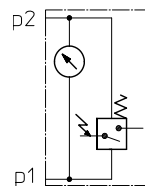

1+2 normally open

Dimensions: mm

Designs and performance values are subject to change.

EDV 05/19

5. Functioning:

The clogging indicator OE is a combined visual and electrical pressure difference indicator.

This type of pressure difference indicator can be mounted on all pressure filters with operating pressure ≤ 63 bar, if the corresponding measuring ports on the filter housing are available.

With contamination of the filter element the difference between the supply pressure and the output pressure of the filter is increasing. Depending on this pressure difference but independent of the operating pressure, visual and electrical signals are released.

The visual control signal is indicated by a blue-red scale which is connected to the magnetic measuring piston.

In the range of low pressure differences - depending on the gauge length of the measuring piston - the blue range of the scale appears first.

The indicated switching pressure difference is reached when the dividing line between the red and the blue range of the scale points to the marking on the display window.

6. Operating instruction:

- Connection

Upon connecting the indicator to the filter make sure that the display window visual indicator shows upwards.

Note: Consider data and connecting conditions mentioned in items 2 to 4.

7. Maintenance:

The device is maintenance-free. However, make sure that no solvents get in touch with the display window visual indicator nor with the piston-spring-system of the clogging indicator.