

POLYLINE™ Single Bag Filter Housing



Choice of PPL or PVDF construction for ultra-pure or corrosive applications

Eaton's POLYLINE single bag filter housing is an all-plastic, rugged polypropylene or PVDF construction for superior corrosion resistance. The glass fiber reinforced polypropylene withstands high-pressure and temperature combinations.

This single bag filter housing has no metal components to rust, corrode or contaminate the process media and is ideal for contamination sensitive or severely corrosive applications. Units come standard with filter bag size 01 or 02 polypropylene or size 02 PVDF restrainer baskets.

Features

- All plastic construction with smooth interior surfaces makes it easy to clean
- Compression hold down creates 360 degree sealing between the filter bag and the bag filter housing

- Removable, "no tools required" spin-off cover for quick filter bag change-outs. Just a few turns of the cover using the built-in handle and the housing opens and closes with little effort
- Standard design available with threaded or flanged connections
- Vent/bleed valve installed on the housing cover and an integral mounting flange for rock-solid installation without the need for support legs
- Dual outlets allow either in-line or loop piping connections with other outlet used as a drain

Options

- Available in glass fiber reinforced polypropylene or PVDF
- Viton® seals and gaskets for the cover and restrainer basket are standard. EPDM seals and gaskets are available
- Multiple I/O connections to suit application
- Round bottom restrainer basket size 01 or 02 available in polypropylene

Viton® is a registered trademark of E. I. du Pont de Nemours and company.

For more information:

WEB: FLTR.com.au **PHONE:** (+61) 1300 62 4020 **EMAIL:** info@FLTR.com.au **SKYPE:** Purple.Engineering

POLYLINE Single Bag Filter Housing

Applications

Coarse filtration > 500 µm ✓
 Medium filtration > 10 µm ✓
 Fine filtration < 10 µm

Pre-filtration ✓
 Safety filtration ✓
 High volume ✓
 Batch filtration ✓
 Circuit filtration ✓
 Continuous filtration

Solvents, paints ✓
 Fats and oils ✓
 Catalyst, activated carbon ✓
 Acids, bases ✓
 Petrochemicals ✓
 Water, waste water ✓
 Chemical industry ✓
 Pharmaceuticals ✓
 Metal cleaning ✓
 Automotive ✓
 Food and beverage ✓
 Paint and lacquer ✓
 Water treatment ✓
 Galvanic industry ✓

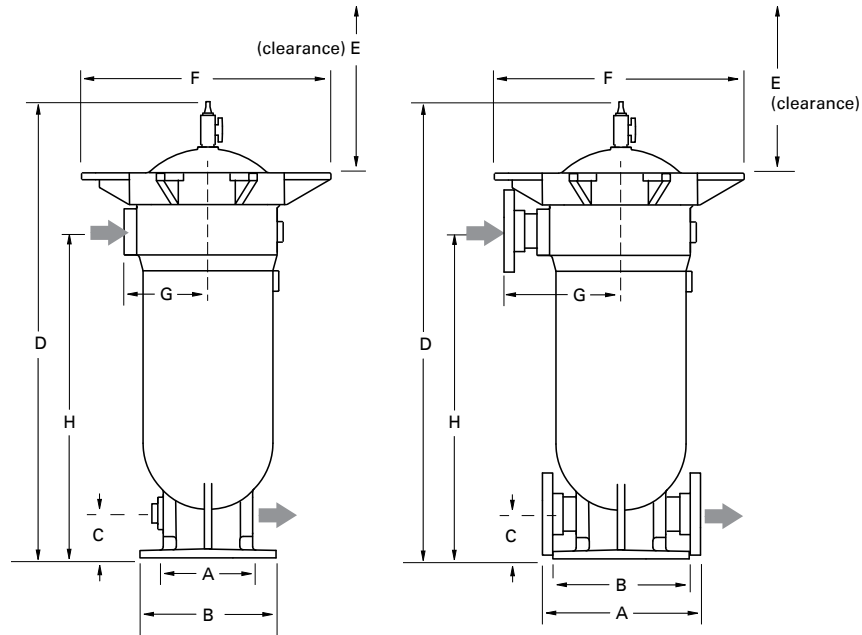

Operating temperature/
 pressure for POLYLINE
 single bag filter housings

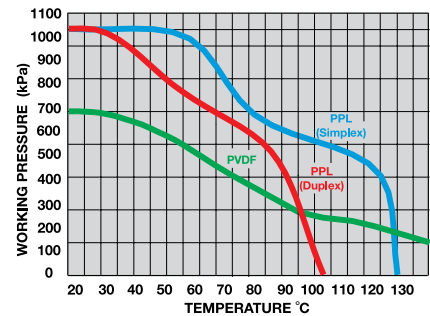

Dimensions - mm

Models	A	B	C	D	E	F	G	H
PBF-0101	165	254	83	867	510	467	156	610
PBF-0102	165	254	83	1273	920	467	156	1016
PBF-0101	290	254	83	867	510	467	219	610
PBF-0102	290	254	83	1273	920	467	219	1016

Dimensions for reference only and approximate. Exact dimensions for installation purposes available on request.

Technical data

Models	No. of filter bags	Size	Flow rate ¹ m ³ /h	Max. pressure bar	Max. temp. °C	Housing volume l	Housing weight kg	I/O connections
PBF-0101	1	1	12	10 @ 21 °C	115 @ 4.8 bar	25	23	2" BSP female thread
PBF-0102	1	2	24	10 @ 21 °C	115 @ 4.8 bar	36	29	2" BSP female thread
PBF-0101	1	1	12	10 @ 21 °C	115 @ 4.8 bar	25	25	DN 50 PN 16 (DIN flange)
PBF-0102	1	2	24	10 @ 21 °C	115 @ 4.8 bar	36	31	DN 50 PN 16 (DIN flange)

¹ Maximum theoretical flow based on water viscosity, filter bag specific.

For more information:

WEB: FLTR.com.au PHONE: (+61) 1300 62 4020 EMAIL: info@FLTR.com.au SKYPE: Purple.Engineering