

# Series TEF 625 DN50 PN10

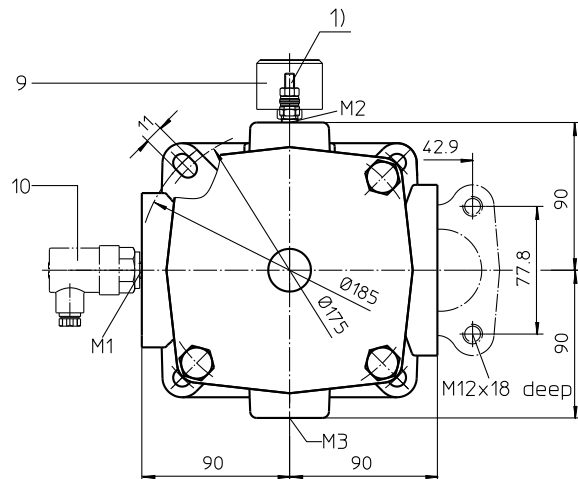
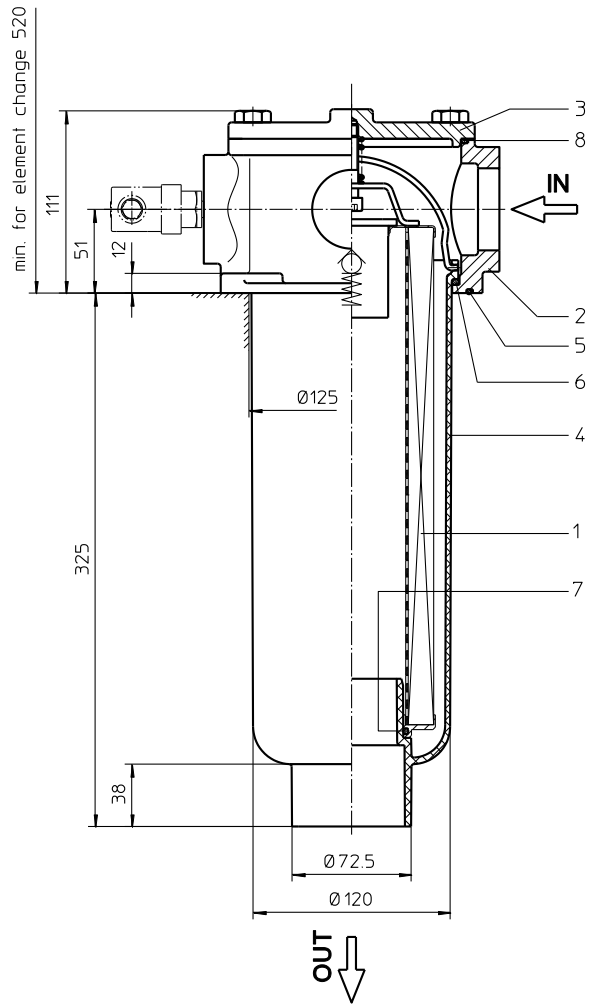

- 1) Connection for the potential equalization, only for application in the explosive area.

weight: approx. 4,5 kg

Dimensions: mm

Designs and performance values are subject to change!

EDV 10/19

# Return Line Filter

## Series TEF 625

### DN50 PN10

#### Description:

Return-line filter series TEF 625 have a working pressure up to 10 bar. Pressure peaks will be absorbed by a sufficient margin of safety.

The TEF-filters are directly mounted to the reservoir and connected to the return-line.

The filter element consists of a star-shaped, pleated filter material which is supported on the inside by a perforated core tube and is bonded to the end caps with a high-quality adhesive. The flow is from outside to inside.

For cleaning the stainless steel mesh element (see special leaflets 21070-4 and 39448-4) or changing the filter element, remove the cover and take out the element. The mesh elements are not guaranteed to maintain 100% performance after cleaning.

Filters finer than 40 µm use the disposable elements made of paper or microglass. Filter elements as fine as 5 µm(c) are available; finer filter elements on request.

Eaton filter elements are known as stable elements which have excellent filtration capabilities and a high dirt retaining capacity, therefore having a long service life. Due to its practical design, the return-line filter is easy to service.

Eaton filter can be used for petroleum-based fluids, HW emulsions, water glycols, most synthetic fluids and lubrication fluids. Consult factory for specific fluid applications.

When changing the filter element, a detachable connection between the filter head and the filter bowl prevents dirty oil from flowing into the tank.

#### 1. Type index:

##### 1.1. Complete filter: (ordering example)

**TEF. 625. 10VG. 16. S. P. -. FS. 8. -. E1. O. -**

1	2	3	4	5	6	7	8	9	10	11	12	13
---	---	---	---	---	---	---	---	---	----	----	----	----

- |    |   |
|----|---|
| 1  | <b>series:</b><br>TEF = tank-mounted return-line-filter   |
| 2  | <b>nominal size:</b> 625  |
| 3  | <b>filter-material:</b><br>80G, 40G, 25G stainless steel wire mesh<br>25VG, 16VG, 10VG, 6VG, 3VG microglass<br>10P paper  |
| 4  | <b>filter element collapse rating:</b><br>16 = Δp 16 bar  |
| 5  | <b>filter element design:</b><br>E = without by-pass valve<br>S = with by-pass valve Δp 2,0 bar<br>S1 = with by-pass valve Δp 3,5 bar   |
| 6  | <b>sealing material:</b><br>P = Nitrile (NBR)<br>V = Viton (FPM)  |
| 7  | <b>filter element specification:</b><br>- = standard<br>IS06 = for HFC applications, see sheet-no. 31601  |
| 8  | <b>process connection:</b><br>FS = SAE-flange connection 3000 PSI   |
| 9  | <b>process connection size:</b><br>8 = 2"   |
| 10 | <b>filter housing specification:</b><br>- = standard<br>IS06 = for HFC applications, see sheet-no. 31605<br>IS10 = for ATEX, see sheet-no. 68267<br>IS11 = for mining applications, see sheet-no. 40530   |
| 11 | <b>clogging indicator at M1:</b><br>- = without<br>O = visual, see sheet-no. 1616<br>E1 = pressure switch, see sheet-no. 1616<br>E2 = pressure switch, see sheet-no. 1616<br>E5 = pressure switch, see sheet-no. 1616<br>PA = ground connection |
| 12 | <b>clogging indicator at M2:</b><br>possible indicators see position 11 of the type index   |
| 13 | <b>clogging indicator at M3:</b><br>possible indicators see position 11 of the type index   |

To add an indicator to your filter, use the corresponding indicator data sheet to find the indicator details and add them to the filter assembly model code.

##### 1.2. Filter element: (ordering example)

**01E. 631. 10VG. 16. S. P. -**

1	2	3	4	5	6	7
---	---	---	---	---	---	---

- |   |   |
|---|---|
| 1 | <b>series:</b><br>01E. = filter element according to company standard |
| 2 | <b>nominal size:</b> 631  |
| 3 | - 7   see type index-complete filter                                  |

#### Accessories:

- SAE-counter flange, see sheet-no. 1652

## Technical data:

operating temperature:	-10°C to +100°C
operating medium	mineral oil, other media on request
max. operating pressure:	10 bar
opening pressure by-pass valve:	2,0 bar; 3,5 bar
process connection:	SAE-flange connection 3000 PSI
housing material standard:	filter head and cover AL, / filter bowl glass fiber reinforced polyamide
housing material IS10, category 2 and 3:	filter head and cover AL, / filter bowl carbon fiber reinforced polyamide
housing material IS11, category M2:	filter head and cover GG, / filter bowl carbon fiber reinforced polyamide
sealing material:	Nitrile (NBR) or Viton (FPM), other materials on request
installation position:	vertical
volume tank:	3,7 l

Classified under the Pressure Equipment Directive 2014/68/EU for mineral oil (fluid group 2), Article 4, Para. 3.  
 Classified under ATEX Directive 2014/34/EU according to specific application (see questionnaire sheet-no. 34279-4).

## Pressure drop flow curves:

### Filter calculation/sizing

The pressure drop of the assembly at a given flow rate Q is the sum of the housing  $\Delta p$  and the element  $\Delta p$  and is calculated as follows:

$$\Delta p_{assembly} = \Delta p_{housing} + \Delta p_{element}$$

$$\Delta p_{housing} = (\text{see } \Delta p = f(Q) \text{ - characteristics})$$

$$\Delta p_{element} (mbar) = Q \left( \frac{l}{min} \right) \times \frac{MSK (mbar)}{10 \left( \frac{l}{min} \right)} \times v \left( \frac{mm^2}{s} \right) \times \frac{\rho (kg)}{0,876 (dm^3)}$$

For ease of calculation our Filter Selection tool is available online at [www.eatonpowersource.com/calculators/filtration/](http://www.eatonpowersource.com/calculators/filtration/)

### Material gradient coefficients (MSK) for filter elements

The material gradient coefficients in mbar/(l/min) apply to mineral oil (HLP) with a density of 0,876 kg/dm<sup>3</sup> and a kinematic viscosity of 30 mm<sup>2</sup>/s (139 SUS). The pressure drop changes proportionally to the change in kinematic viscosity and density.

TEF	VG					G			P
	3VG	6VG	10VG	16VG	25VG	25G	40G	80G	10P
625	0,533	0,370	0,237	0,206	0,141	0,0193	0,0180	0,0123	0,116

### $\Delta p = f(Q)$ – characteristics according to ISO 3968

The pressure drop characteristics apply to mineral oil (HLP) with a density of 0,876 kg/dm<sup>3</sup>. The pressure drop changes proportionally to the density.

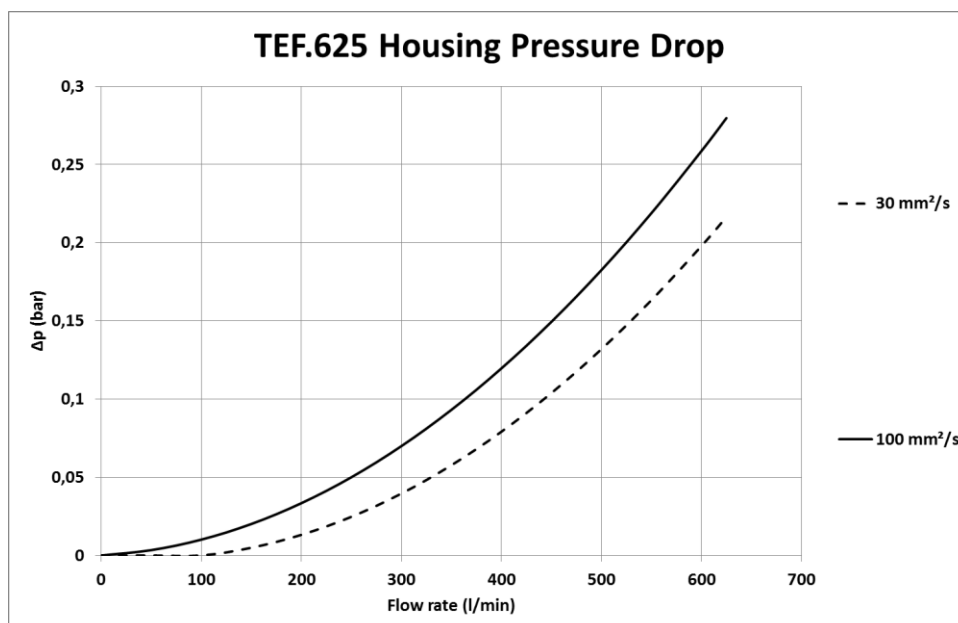

For more information:

WEB: FLTR.com.au PHONE: (+61) 1300 62 4020 EMAIL: info@FLTR.com.au SKYPE: Purple.Engineering

## Symbols:

without indicator

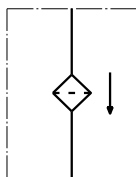

with by-pass valve

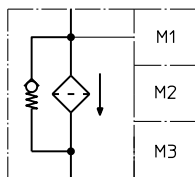

visual O



electric contact maker  
E1



electric contact breaker  
E5



electric contact maker/breaker  
E2



## Spare parts:

item	qty.	designation	dimension	article-no.	
1	1	filter element	01.E631...		
2	1	filter head			
3	1	filter cover			
4	1	filter bowl	NG 625		
5	1	O-ring	140 x 3	304602 (NBR)	308140 (FPM)
6	1	O-ring	120 x 4	301914 (NBR)	304765 (FPM)
7	1	O-ring	63 x 3,5	302222 (NBR)	304384 (FPM)
8	1	O-ring	135 x 3,5	303963 (NBR)	307762 (FPM)
9	1	clogging indicator, visual	O	301721	
10	1	clogging indicator electric	E1, E2 or E5	see sheet-no. 1616	

## Test methods:

Filter elements are tested according to the following ISO standards:

ISO 2941	Verification of collapse/burst resistance
ISO 2942	Verification of fabrication integrity
ISO 2943	Verification of material compatibility with fluids
ISO 3723	Method for end load test
ISO 3724	Verification of flow fatigue characteristics
ISO 3968	Evaluation of pressure drop versus flow characteristics
ISO 16889	Multi-pass method for evaluating filtration performance