

TOPLINE™ Single Bag Filter Housing



The best single bag filter housing for the most demanding applications

Eaton's TOPLINE single bag filter housing is the best bag filter housing for the most demanding applications and features easy filter bag change-outs as well as providing optimum sealing of the filter bag.

This single bag filter housing is simply the best, from its high-performance design to its heavy-duty investment-cast components. Units come standard with filter bag size 01 or 02 stainless steel restrainer baskets.

Features

- Top inlet requires less headroom and allows liquid flow through the cover, improves sealing, reduces product loss and makes filter bag change-outs cleaner
- Smooth, bead-blasted finish, coupled with a minimum two-weld design makes it easy to completely clean the interior
- Adjustable mounting legs for simplified installation
- Designed in accordance with "AD 2000-Merkblätter", EN 13445 and PED
- Available in 316 Ti stainless steel for high corrosion resistance

Options

- Magnetic inserts to collect metallic chips, fines and dust for sizes 01 and 02
- Buna-N® O-rings for the cover are standard. EPDM, Viton®, PTFE encapsulated Viton or silicone rubber seals and gaskets are available
- Multiple I/O connections to suit application
- Available with eye-bolt closure (TBF) or T-bolt (TTBF) closure for faster maintenance

Viton® is a registered trademark of E. I. du Pont de Nemours and company.



TOPLINE with T-bolt closure (TTBF)



Top inlet connection with hinged cover make filter bag change-outs quick and easy

For more information:

WEB: FLTR.com.au **PHONE:** (+61) 1300 62 4020 **EMAIL:** info@FLTR.com.au **SKYPE:** Purple.Engineering

TOPLINE Single Bag Filter Housing

Applications

Coarse filtration > 500 µm	
Medium filtration > 10 µm	✓
Fine filtration < 10 µm	✓
Pre-filtration	✓
Safety filtration	✓
High volume	
Batch filtration	✓
Circuit filtration	✓
Continuous filtration	
Solvents, paints	✓
Fats and oils	✓
Catalyst, activated carbon	✓
Acids, bases	✓
Petrochemicals	✓
Water, waste water	✓
Chemical industry	✓
Pharmaceuticals	✓
Metal cleaning	✓
Automotive	✓
Electronics	✓
Food and beverage	✓
Paint and lacquer	✓
Water treatment	✓
Galvanic industry	✓

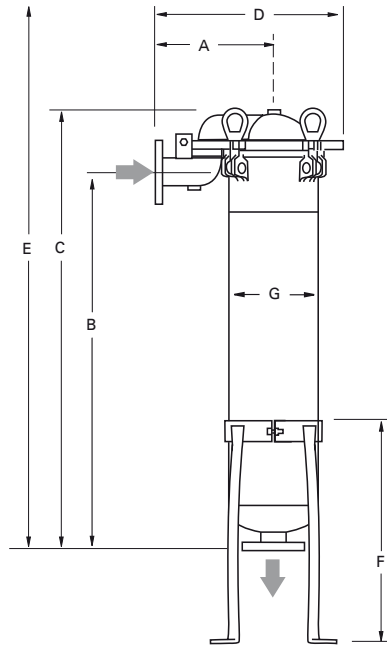

TBF-01 single configuration

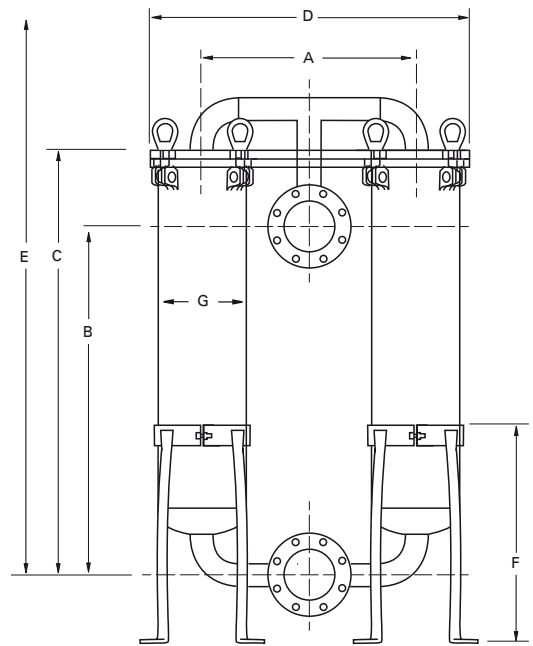

TBF-02 dual configuration

Dimensions - mm

Models	A	B	C	D	E	F	G
TBF-0101	307	395	540	486	813	489	219
TBF-0102	307	790	934	486	1600	489	219
TBF-0201	235	230	569	235	n/a	n/a	219
TBF-0202	235	620	964	235	n/a	n/a	219
TTBF-0101	350	375	570	500	882	620	219
TTBF-0102	350	750	944	500	1247	620	219

Dimensions for reference only and approximate. Exact dimensions for installation purposes available on request.

Technical data

Models	No. of filter bags	Size	Flow rate ¹ m ³ /h	Max. pressure bar	Max. temp. °C	Housing volume l	Housing weight kg	I/O connections
TBF-0101	1	1	20	10	160	13	36	DN 50 PN 16 (DIN flange)
TBF-0102	1	2	40	10	160	27.5	42	DN 50 PN 16 (DIN flange)
TBF-0201	2	1	40	10	160	37	80	DN 80 PN 16 (DIN flange)
TBF-0202	2	2	80	10	160	85	130	DN 80 PN 16 (DIN flange)
TTBF-0101	1	1	20	16	160	15	54	DN 50 PN 16 (DIN flange)
TTBF-0102	1	2	40	16	160	28	60	DN 50 PN 16 (DIN flange)

¹ Maximum theoretical flow based on water viscosity, filter bag specific.

For more information:

WEB: FLTR.com.au PHONE: (+61) 1300 62 4020 EMAIL: info@FLTR.com.au SKYPE: Purple.Engineering