

Series TRS 625 DN50 PN10

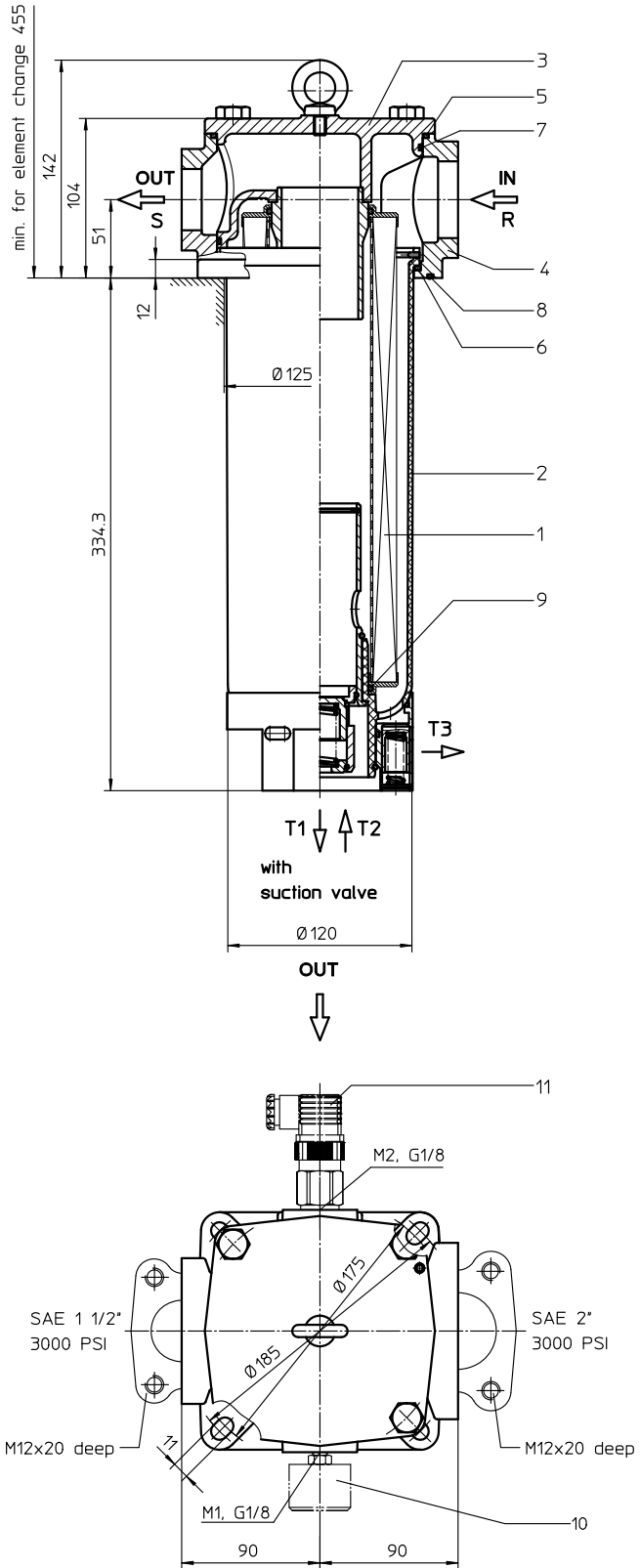

Weight: approx. 7 kg

Dimensions: mm

Designs and performance values are subject to change.

EDV 04/19

Return Line Filter

Series TRS 625

DN50 PN10

Description:

Return-line filters in the TRS 625 series are suitable for a working pressure up to 10 bar. Pressure peaks will be absorbed by a sufficient margin of safety.

TRS series are tank-top mounted in-line filters. In addition to the return-line connection, they have a suction connection on the clean-side. This suction connection has a preload pressure (fitting pressure) of $\geq 0,5$ bar.

This combination, return-line and suction filter, is for hydraulic circuits which are equipped with a minimum 2 feed pumps (2 hydraulic circuits). The preload suction connection is for the full volume flow filtration of the pump with the smaller volume flow.

The operating status in general wherein the preload pressure is effective the Q_R (return-line flow) $>$ Q_S . When the operating status is $Q_R = Q_S$ no preload pressure is effective.

For circuits wherein the operating status $Q_R <$ Q_S appears for a short time, the suction valve operates and as a result a feeding out of the vessel is possible without preload pressure and without filter effect.

The filter element consists of star-shaped, pleated filter material, which is supported on the inside by a perforated core tube and is bonded to the end caps with a high-quality adhesive. The flow direction is from outside to inside.

For cleaning the stainless steel mesh element (see special leaflets 21070-4 and 39448-4) or changing the filter element, remove the cover and take out the element. The mesh elements are not guaranteed to maintain 100% performance after cleaning.

Filters finer than 40 μ m use the disposable elements made of paper or microglass. Filter elements as fine as 5 μ m(c) are available; finer filter elements on request.

Eaton filter elements are known as stable elements which have excellent filtration capabilities and a high dirt retaining capacity, therefore having a long service life. Due to its practical design, the return-line filter is easy to service.

Eaton filter can be used for petroleum-based fluids, HW emulsions, water glycols, most synthetic fluids and lubrication fluids. Consult factory for specific fluid applications.

When changing the filter element, a detachable connection between the filter head and the filter bowl prevents dirty oil from flowing into the tank.

1. Type index:

1.1. Complete filter: (ordering example)

TRS. 625. 10VG. 10. B. P. -, FS. 8. -.

| | | | | | | | | | |
|---|---|---|---|---|---|---|---|---|----|
| 1 | 2 | 3 | 4 | 5 | 6 | 7 | 8 | 9 | 10 |
|---|---|---|---|---|---|---|---|---|----|

S2,5. Z. O. E2

| | | | |
|----|----|----|----|
| 11 | 12 | 13 | 14 |
|----|----|----|----|

- 1 | **series:**
TRS = tank-mounted return-line filter with suction connection
- 2 | **nominal size:** 625
- 3 | **filter-material:**
80G, 40G, 25G stainless steel wire mesh
25VG, 16VG, 10VG, 6VG, 3VG microglass
10P paper
- 4 | **filter element collapse rating:**
10 = Δp 10 bar
- 5 | **filter element design:**
B = both sides open
- 6 | **sealing material:**
P = Nitrile (NBR)
V = Viton (FPM)
- 7 | **filter element specification:**
- = standard
- 8 | **process connection:**
FS = SAE-flange connection 3000 PSI
- 9 | **process connection size:**
8 = 2"
- 10 | **filter housing specification:**
- = standard
- 11 | **internal valve:**
S2,5 = with by-pass valve Δp 2,5 bar
- 12 | **suction valve:**
Z = with suction valve
- 13 | **clogging indicator at M1:**
- = without
O = visual, see sheet-no. 1616
E1 = pressure switch, see sheet-no. 1616
E2 = pressure switch, see sheet-no. 1616
E5 = pressure switch, see sheet-no. 1616
- 14 | **preload pressure indicator at M2:**
- = without
E2 = pressure switch, see sheet-no. 1616

To add an indicator to your filter, use the corresponding indicator data sheet to find the indicator details and add them to the filter assembly model code.

1.2. Filter element: (ordering example)

01E. 625. 10VG. 10. B. P. -

| | | | | | | |
|---|---|---|---|---|---|---|
| 1 | 2 | 3 | 4 | 5 | 6 | 7 |
|---|---|---|---|---|---|---|

- 1 | **series:**
01E = filter element according to company standard
- 2 | **nominal size:** 625
- 3 | - 7 | see type index-complete filter

Technical data:

| | |
|---------------------------------|--|
| operating temperature: | -10°C to +100°C |
| operating medium | mineral oil, other media on request |
| max. operating pressure: | 10 bar |
| opening pressure by-pass valve: | 2,5 bar |
| opening pressure preload valve: | 0,5 bar |
| opening pressure suction valve: | 0,05 bar |
| line adapter: | SAE 2" and SAE 1 1/4" 3000 PSI |
| housing material: | Al-casting, glass fibre reinforced polyamide (filter bowl) |
| sealing material: | Nitrile (NBR) or Viton (FPM), other materials on request |
| installation position: | vertical |
| volume tank: | 3,7 l |

Classified under the Pressure Equipment Directive 2014/68/EU for mineral oil (fluid group 2), Article 4, Para. 3.
 Classified under ATEX Directive 2014/34/EU according to specific application (see questionnaire sheet-no. 34279-4).

Pressure drop flow curves:

Filter calculation/sizing

The pressure drop of the assembly at a given flow rate Q is the sum of the housing Δp and the element Δp and is calculated as follows:

$$\Delta p_{assembly} = \Delta p_{housing} + \Delta p_{element}$$

$$\Delta p_{housing} = (\text{see } \Delta p = f(Q) \text{ - characteristics})$$

$$\Delta p_{element} (mbar) = Q \left(\frac{l}{min} \right) \times \frac{MSK (mbar)}{10 (l/min)} \times v \left(\frac{mm^2}{s} \right) \times \frac{\rho (kg)}{0,876 (dm^3)}$$

For ease of calculation our Filter Selection tool is available online at www.eatonpowersource.com/calculators/filtration/

Material gradient coefficients (MSK) for filter elements

The material gradient coefficients in mbar/(l/min) apply to mineral oil (HLP) with a density of 0,876 kg/dm³ and a kinematic viscosity of 30 mm²/s (139 SUS). The pressure drop changes proportionally to the change in kinematic viscosity and density.

| TRS | VG | | | | | G | | | P |
|-----|-------|-------|-------|-------|-------|--------|--------|--------|-------|
| | 3VG | 6VG | 10VG | 16VG | 25VG | 25G | 40G | 80G | 10P |
| 625 | 0,578 | 0,401 | 0,257 | 0,224 | 0,153 | 0,0193 | 0,0180 | 0,0123 | 0,116 |

$\Delta p = f(Q)$ – characteristics according to ISO 3968

The pressure drop characteristics apply to mineral oil (HLP) with a density of 0,876 kg/dm³. The pressure drop changes proportionally to the density.

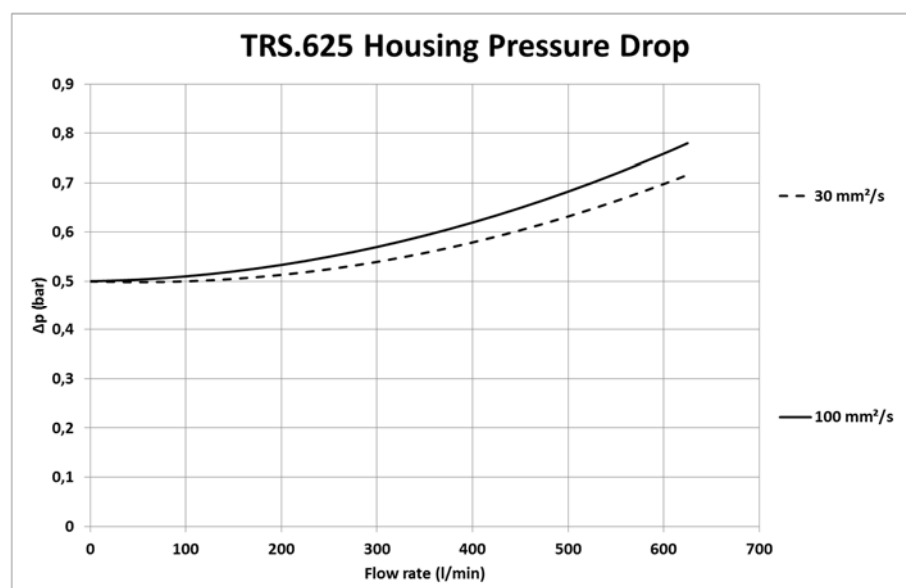

For more information:

WEB: FLTR.com.au PHONE: (+61) 1300 62 4020 EMAIL: info@FLTR.com.au SKYPE: Purple.Engineering

Symbols:

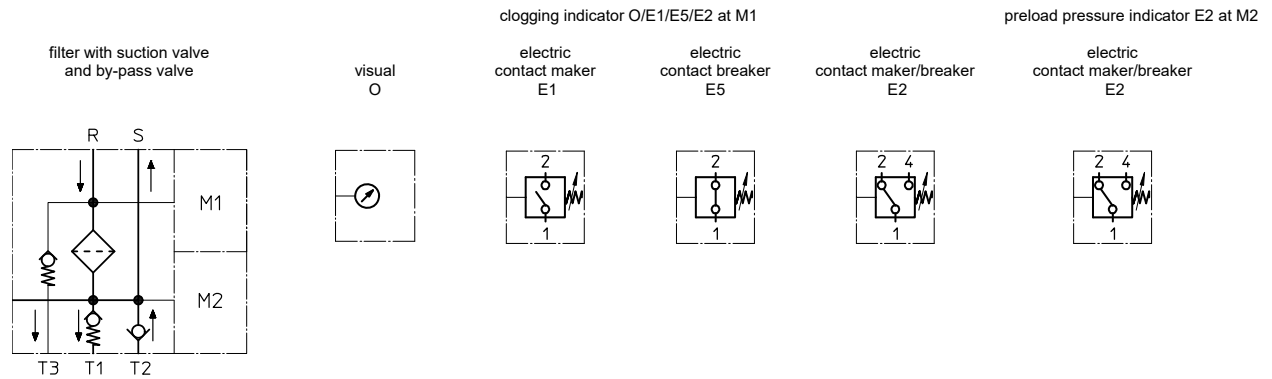

Spare parts:

| item | qty. | designation | dimension | article-no. | |
|------|------|------------------------------------|-----------------|--------------------|--------------|
| 1 | 1 | filter element | 01E.625... | | |
| 2 | 1 | filter bowl with valve combination | | | |
| 3 | 1 | Filter cover | | | |
| 4 | 1 | filter head | | | |
| 5 | 1 | O-ring | 135 x 3,5 | 318386 (NBR) | 318387 (FPM) |
| 6 | 1 | O-ring | 120 x 4 | 305300 (NBR) | 307991 (FPM) |
| 7 | 1 | O-ring | 125 x 3 | 306025 (NBR) | 307358 (FPM) |
| 8 | 1 | O-ring | 140 x 3 | 304604 (NBR) | 307514 (FPM) |
| 9 | 2 | O-ring | 63 x 3,5 | 311189 (NBR) | 311592 (FPM) |
| 10 | 1 | clogging indicator at M1 | O, E1, E5 or E2 | see sheet-no. 1616 | |
| 11 | 1 | preload pressure indicator at M2 | E2 | see sheet-no. 1616 | |

Test methods:

Filter elements are tested according to the following ISO standards:

| | |
|-----------|---|
| ISO 2941 | Verification of collapse/burst resistance |
| ISO 2942 | Verification of fabrication integrity |
| ISO 2943 | Verification of material compatibility with fluids |
| ISO 3723 | Method for end load test |
| ISO 3724 | Verification of flow fatigue characteristics |
| ISO 3968 | Evaluation of pressure drop versus flow characteristics |
| ISO 16889 | Multi-pass method for evaluating filtration performance |

For more information:

WEB: FLTR.com.au PHONE: (+61) 1300 62 4020 EMAIL: info@FLTR.com.au SKYPE: Purple.Engineering