

Series TRW 310 DN32 PN10

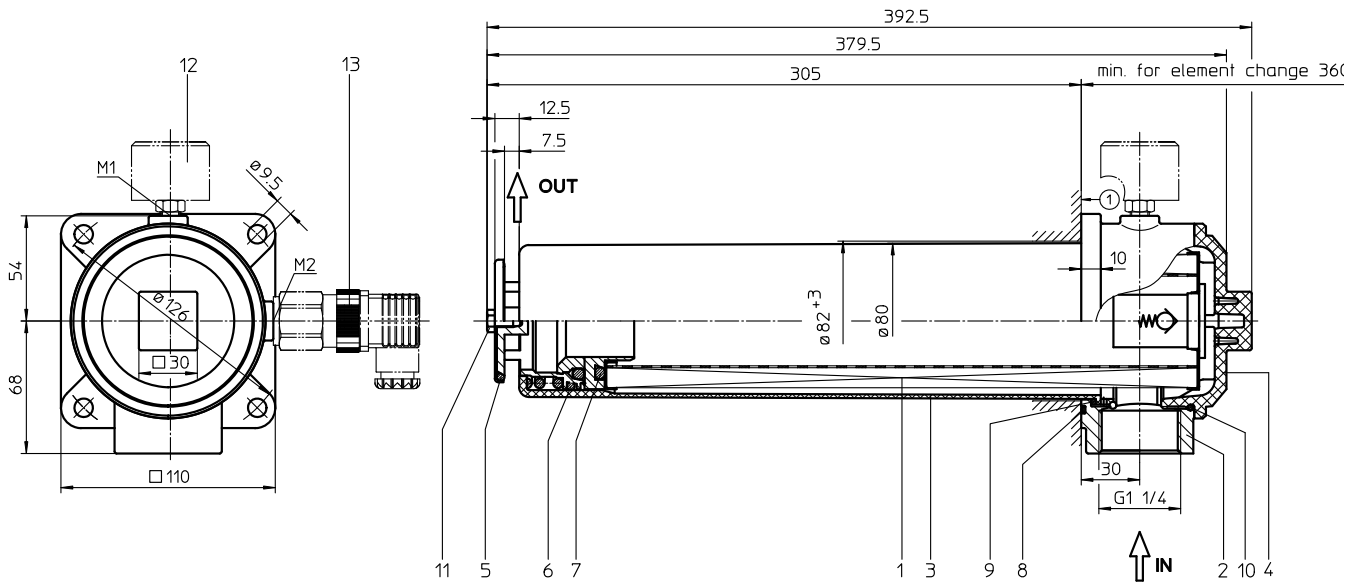

- mounting surface 1
- surface quality $\sqrt{Ra3.2}$
- flatness tolerance $\square 0.2$

Weight: approx. 3,5 kg

Dimensions: mm

Designs and performance values are subject to change.

EDV 04/19

For more information:

WEB: FLTR.com.au PHONE: (+61) 1300 62 4020 EMAIL: info@FLTR.com.au SKYPE: Purple.Engineering



Return Line Filter

Series TRW 310

DN32 PN10

Description:

Return-line filters in the TRW 310 series are suitable for a working pressure up to 10 bar. Pressure peaks will be absorbed by a sufficient margin of safety.

The TRW-filters are directly mounted to the reservoir and connected to the return-line. The return-area „IN“ must be below the oil level.

The filter element consists of star-shaped, pleated filter material, which is supported on the inside by a perforated core tube and is bonded to the end caps with a high-quality adhesive. The flow direction is from outside to inside.

For cleaning the stainless steel mesh element (see special leaflets 21070-4 and 39448-4) or changing the microglass element, remove the cover and take out the element. The mesh elements are not guaranteed to maintain 100% performance after cleaning.

Filters finer than 40 µm use the disposable elements made of paper or microglass. Filter elements as fine as 5 µm(c) are available; finer filter elements on request.

Eaton filter elements are known as stable elements which have excellent filtration capabilities and a high dirt retaining capacity, therefore having a long service life. Due to its practical design, the return-line filter is easy to service.

Eaton filter can be used for petroleum-based fluids, HW emulsions, water glycols, most synthetic fluids and lubrication fluids. Consult factory for specific fluid applications.

When changing the filter element, a detachable connection between the filter head and the filter bowl prevents dirty oil from flowing into the tank.

1. Type index:

1.1. Complete filter: (ordering example)

TRW.	310.	10VG.	16.	S.	P.	-.	G.	6.	-.	O.	E2
1	2	3	4	5	6	7	8	9	10	11	12

- 1 | **series:**
TRW = tank-mounted return-line filter for horizontal tank-mounting
- 2 | **nominal size:** 310
- 3 | **filter-material:**
80G, 40G, 25G stainless steel wire mesh
25VG, 16VG, 10VG, 6VG, 3VG microglass
10P paper
- 4 | **filter element collapse rating:**
16 = Δp 16 bar
- 5 | **filter element design:**
E = without by-pass valve
S = with by-pass valve Δp 2,0 bar
- 6 | **sealing material:**
P = Nitrile (NBR)
V = Viton (FPM)
- 7 | **filter element specification:**
- = standard
- 8 | **process connection:**
G = thread connection according to DIN 3852, T2
- 9 | **process connection size:**
6 = G 1 ¼
- 10 | **filter housing specification:**
- = standard
- 11 | **clogging indicator at M1:**
- = without
O = visual, see sheet-no. 1616
E1 = pressure switch, see sheet-no. 1616
E2 = pressure switch, see sheet-no. 1616
E5 = pressure switch, see sheet-no. 1616
- 12 | **clogging indicator at M2:**
Possible indicators see position 11 of the type index

To add an indicator to your filter, use the corresponding indicator data sheet to find the indicator details and add them to the filter assembly model code.

1.2. Filter element: (ordering example)

01E.	320.	10VG.	16.	S.	P.	-
1	2	3	4	5	6	7

- 1 | **series:**
01E = filter element according to company standard
- 2 | **nominal size:** 320
- 3 | - 7 | see type index-complete filter

Technical data:

operating temperature:	-10°C to +100°C
operating medium	mineral oil, other media on request
max. operating pressure:	10 bar
opening pressure by-pass valve:	2,5 bar
process connection:	thread connection according to DIN 3852, T2
housing material:	Al-casting, glass fibre reinforced polyamide (screw plug, filter bowl)
sealing material:	Nitrile (NBR) or Viton (FPM), other materials on request
installation position:	horizontal
volume tank:	1,5 l

Classified under the Pressure Equipment Directive 2014/68/EU for mineral oil (fluid group 2), Article 4, Para. 3.
 Classified under ATEX Directive 2014/34/EU according to specific application (see questionnaire sheet-no. 34279-4).

Pressure drop flow curves:

Filter calculation/sizing

The pressure drop of the assembly at a given flow rate Q is the sum of the housing Δp and the element Δp and is calculated as follows:

$$\Delta p_{assembly} = \Delta p_{housing} + \Delta p_{element}$$

$$\Delta p_{housing} = (\text{see } \Delta p = f(Q) \text{ - characteristics})$$

$$\Delta p_{element} (mbar) = Q \left(\frac{l}{min} \right) \times \frac{MSK (mbar)}{10 \left(\frac{l}{min} \right)} \times v \left(\frac{mm^2}{s} \right) \times \frac{\rho}{0,876} \left(\frac{kg}{dm^3} \right)$$

For ease of calculation our Filter Selection tool is available online at www.eatonpowersource.com/calculators/filtration/

Material gradient coefficients (MSK) for filter elements

The material gradient coefficients in mbar/(l/min) apply to mineral oil (HLP) with a density of 0,876 kg/dm³ and a kinematic viscosity of 30 mm²/s (139 SUS). The pressure drop changes proportionally to the change in kinematic viscosity and density.

TRW	VG					G			P
	3VG	6VG	10VG	16VG	25VG	25G	40G	80G	10P
310	0,953	0,661	0,423	0,369	0,252	0,0275	0,0257	0,0176	0,206

$\Delta p = f(Q)$ – characteristics according to ISO 3968

The pressure drop characteristics apply to mineral oil (HLP) with a density of 0,876 kg/dm³. The pressure drop changes proportionally to the density.

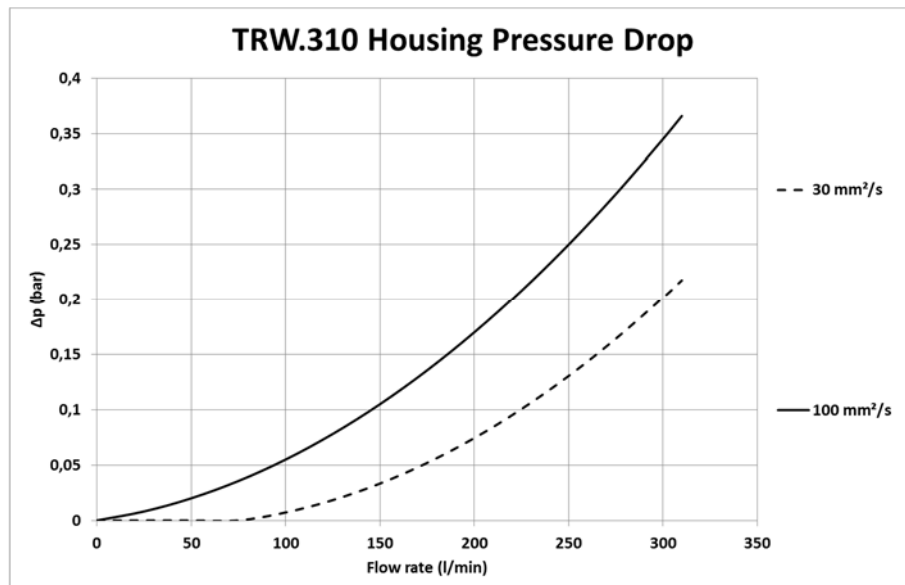

For more information:

WEB: FLTR.com.au PHONE: (+61) 1300 62 4020 EMAIL: info@FLTR.com.au SKYPE: Purple.Engineering

Symbols:

without indicator

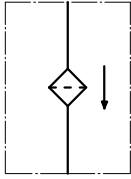

with by-pass valve

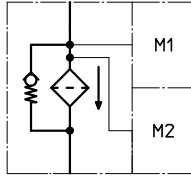

visual O



electric contact maker
E1



electric contact breaker
E5



electric contact maker/breaker
E2



Spare parts:

item	qty.	designation	dimension	article-no.	
1	1	filter element	01E.320...		
2	1	filter head		304423	
3	1	filter bowl			
4	1	screw plug	M 90 x 2	316637	
5	1	O-ring	53 x 4	309143 (NBR)	332434 (FPM)
6	1	O-ring	62 x 4	308045 (NBR)	311472 (FPM)
7	2	O-ring	44 x 6	302222 (NBR)	304384 (FPM)
8	1	O-ring	88 x 3	304417 (NBR)	310266 (FPM)
9	1	O-ring	75 x 3	302215 (NBR)	304729 (FPM)
10	1	O-ring	82 x 3	305191 (NBR)	305298 (FPM)
11	1	sheet metal screw	DIN 7976-F 6,3x13	316641	
12	1	clogging indicator, visual	O	301721	
13	1	pressure switch, electric	E1, E2 or E5	see sheet-no. 1616	

Test methods:

Filter elements are tested according to the following ISO standards:

ISO 2941	Verification of collapse/burst resistance
ISO 2942	Verification of fabrication integrity
ISO 2943	Verification of material compatibility with fluids
ISO 3723	Method for end load test
ISO 3724	Verification of flow fatigue characteristics
ISO 3968	Evaluation of pressure drop versus flow characteristics
ISO 16889	Multi-pass method for evaluating filtration performance