

SUCTION FILTER, for vertical tank-mounting

Series TS 426 DN 40

Sheet No.
1908 E

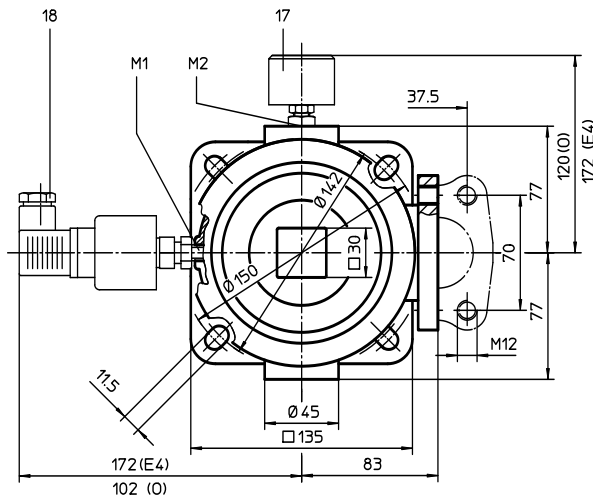
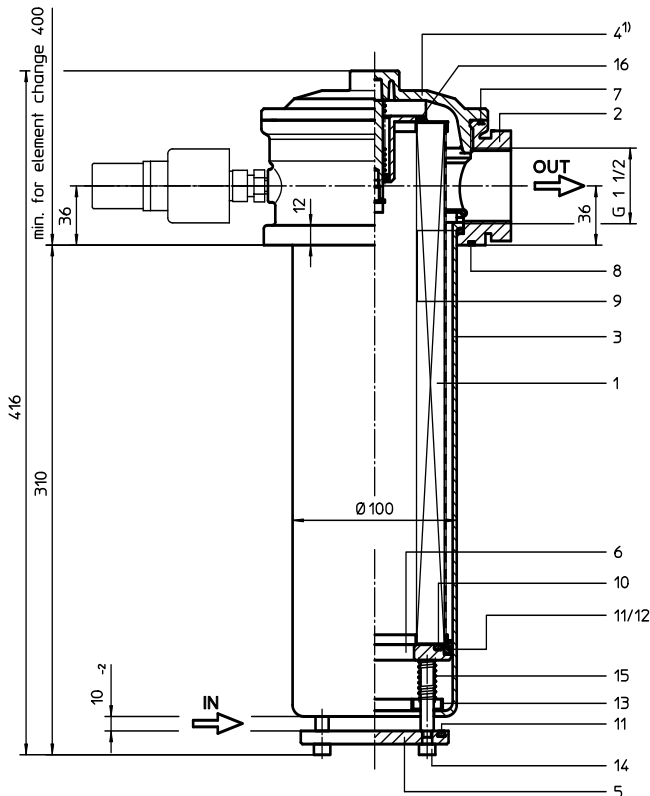

¹⁾ The bypass valve is integrated in the screw plug. For the filter without a by-pass valve the opening function is raised up to $\Delta p > 1$ bar

1. Type index:

1.1. Complete filter: (ordering example)

TS. 426. 10VG. -. B. P. -. G. 7. -. -. E4. O1

1	2	3	4	5	6	7	8	9	10	11	12	13
---	---	---	---	---	---	---	---	---	----	----	----	----

- 1 **series:**
TS = suction filter for vertical tank-mounting
- 2 **nominal size:** 426
- 3 **filter-material and filter-fineness:**
80 G = 80 μm , 40 G = 40 μm ,
25 G = 25 μm stainless steel wire mesh
25 VG = 20 $\mu\text{m}_{(e)}$, 16 VG = 15 $\mu\text{m}_{(e)}$, 10 VG = 10 $\mu\text{m}_{(e)}$,
6 VG = 7 $\mu\text{m}_{(e)}$, 3 VG = 5 $\mu\text{m}_{(e)}$ Interpor fleece (glass fibre)
10 P = 10 μm paper
- 4 **resistance of pressure difference for filter element:**
- = not specified
- 5 **filter element design:**
B = both sides open
- 6 **sealing material:**
P = Nitrile (NBR)
V = Viton (FPM)
- 7 **filter element specification:**
- = standard
VA = stainless steel
- 8 **connection:**
G = thread connection according to DIN 3852, T2
FS = SAE-flange connection 3000 PSI
- 9 **connection size:**
7 = G 1 1/2 or SAE 1 1/2"
- 10 **filter housing specification:**
- = standard
- 11 **internal valve:**
- = without
S = with by-pass valve Δp 0,28 bar
- 12 **clogging indicator at M1:**
- = without
O1 = visual, see sheet-no. 1616
E4 = pressure switch, see sheet-no. 1616
- 13 **clogging indicator at M2:**
possible indicators see position 12 of the type index

1.2. Filter element: (ordering example)

01TS. 425. 10VG. -. B. -. -

1	2	3	4	5	6	7
---	---	---	---	---	---	---

- 1 **series:**
01TS. = suction filter element according to company standard
- 2 **nominal size:** 425
- 3 - 5, 7 see type index-complete filter
- 6 **sealing material:**
- = without

weight: 5,7 kg

Changes of measures and design are subject to alteration!

EDV 08/12

2. Spare parts:

item	qty.	designation	dimension	article-no.	
1	1	filter element	01TS. 425		
2	1	filter head	NG 426		
3	1	filter bowl	NG 426		
4	1	screw plug with by-pass	M 120 x 3		
	1	screw plug without by-pass	M 120 x 3		
5	1	valve disc		311892	
6	1	valve bushing		307548	
7	1	O-ring	128 x 3	304602 (NBR)	308140 (FPM)
8	1	O-ring	115 x 3	303963 (NBR)	307762 (FPM)
9	1	O-ring	98 x 4	301914 (NBR)	304765 (FPM)
10	1	O-ring	70 x 4	306253 (NBR)	310280 (FPM)
11	2	O-ring	76 x 4	305599 (NBR)	310291 (FPM)
12	1	sliding ring		307547	
13	1	pressure ring		307549	
14	1	fillister head cap screw	M 6 x 60	307534	
15	1	spring	1,6 x 10 x 53 x 12.5	311847	
16	1	O-ring	50 x 3	307398 (NBR)	314682 (FPM)
17	1	clogging indicator, visual	O1	301722	
18	1	clogging indicator, electrical	E4	311016	

3. Description:

The TS-filters are directly mounted to the reservoir and connected to the suction-line. The suction-area „IN“ must be below the oil level. The filter element consists of a star-shaped, pleated filter material which is supported on the inside by a perforated core tube and is bonded to the end caps with a high-quality adhesive. The flow is from inside to outside. Filters finer than 40 µm should use throw-away elements made of paper or Interpor fleece (VG). Filter elements as fine as 5 µm_(c) are available; finer filter elements on request.

Internormen Product Line filter elements are known as elements with a high intrinsic stability and an excellent filtration capability, a high dirt-retaining capacity and a long service life.

Internormen Product Line filter are suitable for all petroleum based fluids, HW-emulsions, most synthetic hydraulic fluids and lubrication oils.

Due to its practical design, the return-line filter is easy to service. When releasing the filter cover a plate-shaped valve closes the suction-inlet of the filter bowl and prevents the return flow of dirt oil into the reservoir. For cleaning, the filter bowl together with the filter element can be taken out of the filter head.

4. Technical data:

temperature range:	-10°C to + 80°C (for a short time + 100°C)
operating medium:	mineral oil, other media on request
connection system:	thread connection or SAE-flange connection 3000 PSI
housing material:	Al-casting; glass fibre reinforced polyamide
sealing material:	Nitrile (NBR) or Viton (FPM), other materials on request
installation position:	vertical
volume tank:	2,6 l

Classified under the Pressure Equipment Directive 97/23/EC for mineral oil (fluid group 2), Article 3, Para. 3.

Classified under ATEX Directive 94/9/EC according to specific application (see questionnaire sheet-no. 34279-4).

5. Symbols:

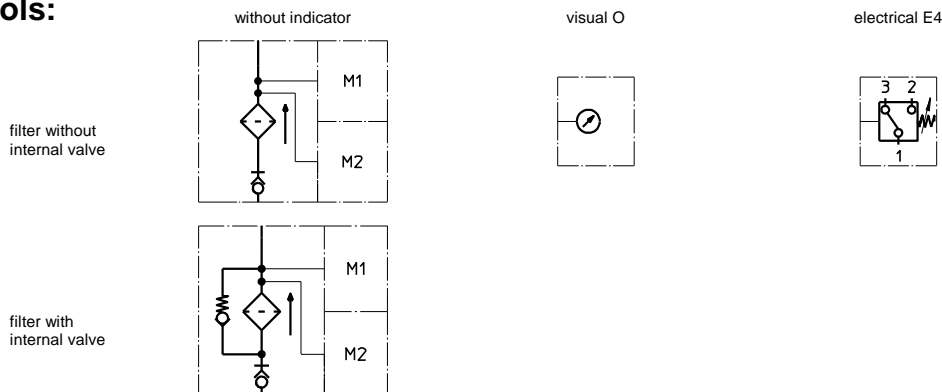

6. Pressure drop flow curves:

Precise flow rates see 'Interactive Product Specifier' respectively Δp -curves ; depending on filter fineness and viscosity.

7. Test methods:

Filter elements are tested according to the following ISO standards:

- ISO 2941 Verification of collapse/burst resistance
- ISO 2942 Verification of fabrication integrity
- ISO 2943 Verification of material compatibility with fluids
- ISO 3723 Method for end load test
- ISO 3724 Verification of flow fatigue characteristics
- ISO 3968 Evaluation of pressure drop versus flow characteristics
- ISO 16889 Multi-pass method for evaluating filtration performance