

# SUCTION FILTER, for horizontal tank-mounting

## Series TSW 426 DN 40

Sheet No.  
**1906 E**

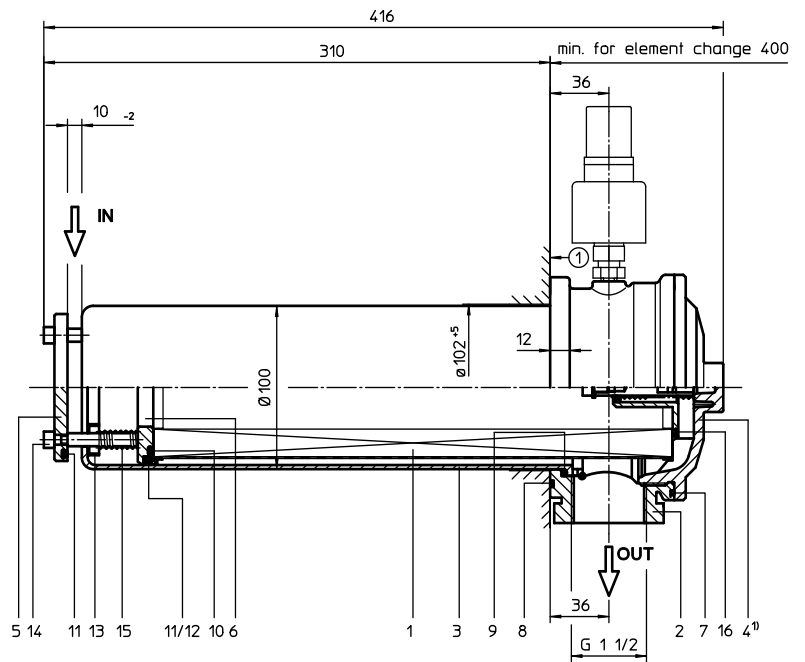
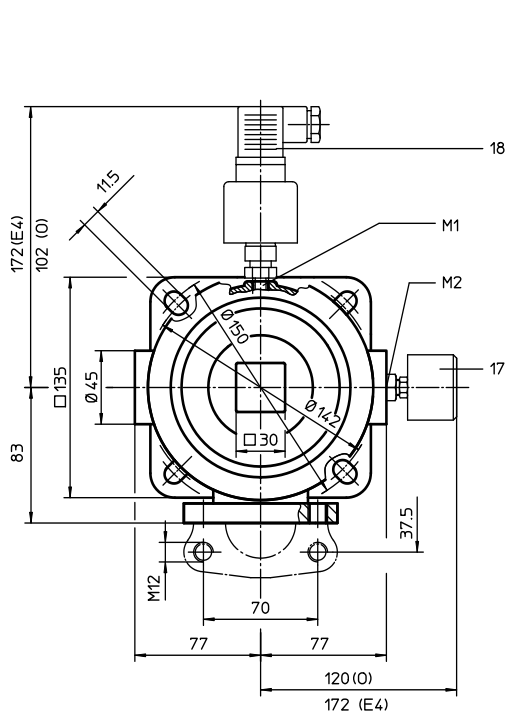

### 1. Type index:

#### 1.1. Complete filter: (ordering example)

**TSW. 426. 10VG. -. B. P. -. G. 7. -. -. E4. O1**

1	2	3	4	5	6	7	8	9	10	11	12	13
---	---	---	---	---	---	---	---	---	----	----	----	----

- 1 | **series:**  
TSW = suction filter for horizontal tank-mounting
- 2 | **nominal size:** 426
- 3 | **filter-material and filter-fineness:**  
80 G = 80  $\mu\text{m}$ , 40 G = 40  $\mu\text{m}$ ,  
25 G = 25  $\mu\text{m}$  stainless steel wire mesh  
25 VG = 20  $\mu\text{m}_{(e)}$ , 16 VG = 15  $\mu\text{m}_{(e)}$ , 10 VG = 10  $\mu\text{m}_{(e)}$ ,  
6 VG = 7  $\mu\text{m}_{(e)}$ , 3 VG = 5  $\mu\text{m}_{(e)}$  Interpor fleece (glass fibre)  
10 P = 10  $\mu\text{m}$  paper
- 4 | **resistance of pressure difference for filter element:**  
- = not specified
- 5 | **filter element design:**  
B = both sides open
- 6 | **sealing material:**  
P = Nitrile (NBR) V = Viton (FPM)
- 7 | **filter element specification:**  
- = standard VA = stainless steel
- 8 | **connection:**  
G = thread connection according to DIN 3852, T2  
FS = SAE-flange connection 3000 PSI
- 9 | **connection size:**  
7 = G 1 1/2 or SAE 1 1/2"
- 10 | **filter housing specification:**  
- = standard
- 11 | **internal valve:**  
- = without S = with by-pass valve  $\Delta p$  0,28 bar
- 12 | **clogging indicator at M1:**  
- = without  
O1 = visual, see sheet-no. 1616  
E4 = pressure switch, see sheet-no. 1616
- 13 | **clogging indicator at M2:**  
possible indicators see position 12 of the type index

#### 1.2. Filter element: (ordering example)

**01TS. 425. 10VG. -. B. -. -**

1	2	3	4	5	6	7
---	---	---	---	---	---	---

- 1 | **series:**  
01TS. = suction filter element according to company standard
- 2 | **nominal size:** 425
- 3 | - 5 | , 7 | see type index complete filter
- 6 | **sealing material:**  
- = without

mounting surface



surface quality



flatness tolerance

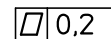

<sup>1)</sup> The by-pass valve is integrated in the screw plug.  
For the filter without a by-pass valve the opening function is raised up to  $\Delta p > 1$  bar.

weight: 5,7 kg

## 2. Spare parts:

item	qty.	designation	dimension	article-no.
1	1	filter element	01TS. 425	
2	1	filter head	NG 426	
3	1	filter bowl	NG 426	303732
4	1	screw plug with by-pass	M 120 x 3	313455
	1	screw plug without by-pass	M 120 x 3	313649
5	1	valve disc		311892
6	1	valve bushing		307548
7	1	O-ring	128 x 3	304602 (NBR) 308140 (FPM)
8	1	O-ring	115 x 3	303963 (NBR) 307762 (FPM)
9	1	O-ring	98 x 4	301914 (NBR) 304765 (FPM)
10	1	O-ring	70 x 4	306253 (NBR) 310280 (FPM)
11	2	O-ring	76 x 4	305599 (NBR) 310291 (FPM)
12	1	sliding ring		307547
13	1	pressure ring		307549
14	1	fillister head cap screw	M 6 x 60	307534
15	1	spring	1,6 x 10 x 53	311847
16	1	O-ring	50 x 3	307398 (NBR) 314682 (FPM)
17	1	clogging indicator, visual	O1	301722
18	1	clogging indicator, electrical	E4	311016

## 3. Description:

The TSW-filters are directly mounted to the reservoir and connected to the suction-line. The filter element consists of a star-shaped, pleated filter material which is supported on the inside by a perforated core tube and is bonded to the end caps with a high-quality adhesive. The flow is from inside to outside. Filters finer than 40  $\mu\text{m}$  should use throw-away elements made of paper or Interpor fleece (VG). Filter elements as fine as 5 $\mu\text{m}$  are available; finer filter elements on request.

Internormen Product Line filter elements are known as elements with a high intrinsic stability and an excellent filtration capability, a high dirt-retaining capacity and a long service life.

Internormen Product Line filter are suitable for all petroleum based fluids, HW-emulsions, most synthetic hydraulic fluids and lubrication oils.

Due to its practical design, the return-line filter is easy to service. When releasing the filter cover a plate-shaped valve closes the suction-inlet of the filter bowl and prevents leakage of fluid out of the tank. Filter element can be removed from the filter pot for cleaning purposes.

## 4. Technical data:

temperature range:	-10°C to + 80°C (for a short time + 100°C)
operating medium:	mineral oil, other media on request
connection system:	thread connection or SAE-flange connection 3000 PSI
housing material:	Al-casting; glass fibre reinforced polyamide
sealing material:	Nitrile (NBR) or Viton (FPM), other materials on request
installation position:	horizontal
volume tank:	2,6 l

Classified under the Pressure Equipment Directive 97/23/EC for mineral oil (fluid group 2), Article 3, Para. 3.

Classified under ATEX Directive 94/9/EC according to specific application (see questionnaire sheet-no. 34279-4).

## 5. Symbols:

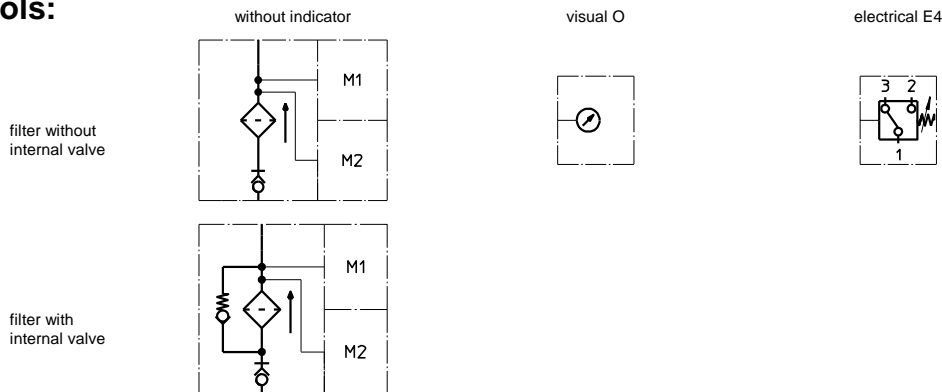

## 6. Pressure drop flow curves:

Precise flow rates see 'Interactive Product Specifier' respectively  $\Delta p$ -curves; depending on filter fineness and viscosity.

## 7. Test methods:

Filter elements are tested according to the following ISO standards:

ISO 2941	Verification of collapse/burst resistance
ISO 2942	Verification of fabrication integrity
ISO 2943	Verification of material compatibility with fluids
ISO 3723	Method for end load test
ISO 3724	Verification of flow fatigue characteristics
ISO 3968	Evaluation of pressure drop versus flow characteristics
ISO 16889	Multi-pass method for evaluating filtration performance

E 1906 E

For more information:

WEB: FLTR.com.au PHONE: (+61) 1300 62 4020 EMAIL: info@FLTR.com.au SKYPE: Purple.Engineering

