

Type T Cast Construction



Type T Cast Iron Separator

- Sizes 3/4" - 4"
- Threaded, Flanged, or Socket Weld
- Cast Iron

FEATURES

- Cast Construction
- High Efficiency Over Wide Flow Range
- No Required Maintenance
- Economical Choice for Most Applications
- Removes 99% of Liquid and Solid Entrainment Particles Larger Than 10 Microns
- Gas, Steam, or Air Applications

OPTIONS

- Integral Trap
- Trap Heating Element
- ASME UM or U Code Stamp (CS and SS Models Only)
- Water Gauge Tap
- Thermometer Tap
- Larger Drain Size

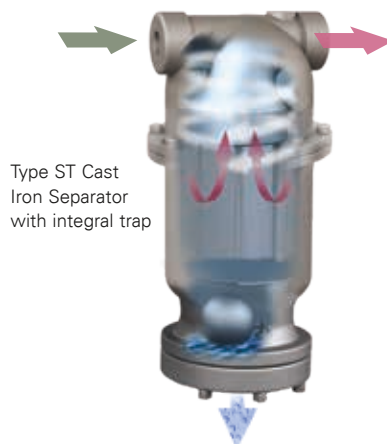

Type ST Cast Iron Separator with integral trap

High Efficiency – No Maintenance

The Eaton Type T Gas/Liquid Separator automatically removes 99% of all liquid and solid entrainment particles 10 microns in size or larger from air, gas, and steam processes. And it does so with no moving parts to wear out and no required maintenance. The Type T, with its cost-effective design, is the separator of choice for most applications that require clean, dry air, gas or steam.

Exclusive Design

Moisture-laden gas enters the inlet of the separator where it is deflected in a centrifugal downward motion. The entrained solids and moisture droplets are separated out by a reduction in velocity. Separated liquid and solids fall into a reservoir where the exclusive Vortex Containment Plate (VCP) ensures that they cannot be re-entrained. The clean, dry flow is then directed to the outlet by the VCP. This eliminates the need for expensive, delicate baffles used in ordinary separators.

Application Flexibility

The basic Type T Gas/Liquid Separator's straightforward, time-proven design fits most applications without options. For more specialized applications, the Type T is available as the Type ST with an integral trap as part of its design. The trap mechanism is a foolproof design which automatically ejects the condensate, without loss of line pressure, when it reaches a predetermined level. The Type ST is compact, easily installed, and can be supported by the line. Removal of the bottom flange releases the trap mechanism for inspection. The internal trap components are rust-proof stainless steel and include a nonmagnetic 18-8 stainless steel valve and seat. For applications below freezing, the Type ST Separator can be ordered as the Type STH that includes a heater for the trap. The heater is rated at 50W and runs with 110 volt service. The self-limiting heating element will keep fluid above freezing but does not add to the line temperature. The heater can be easily removed for inspection.

Type T Cast Gas/Liquid Separators

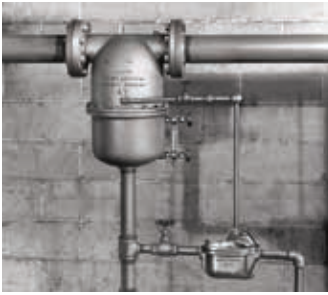

Typical Installation

Selection Table

Pipe Size (in)	Material	Connection	Rating
3/4 to 3	Cast Iron	Threaded	250 psi @ 450°F
2 to 4	Cast Iron	Flanged 125# FF	150 psi @ 353°F 125 psi @ 450°F

Model T Cast Iron Threaded

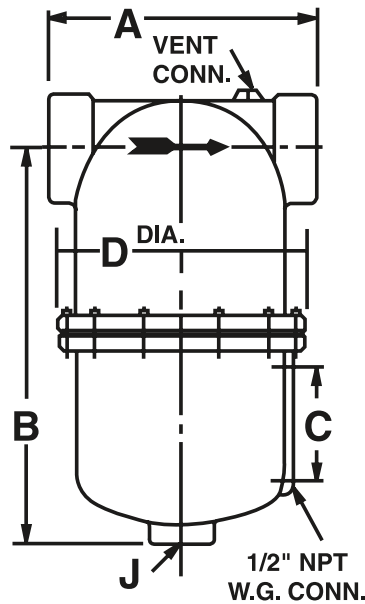

Model T Cast Iron Flanged

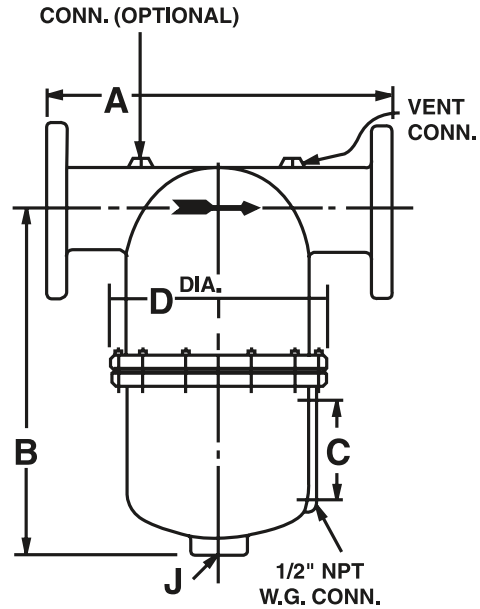

Dimensions* - Model T Threaded (Cast Iron) – (in/mm)

Pipe Size	A	B	C	D	J - NPT Drains		NPT Vent	Weight (lb/kg)
					Regular	Optional		
3/4	5.50 / 40	9.19 / 233	–	5.75 / 146	3/4	–	1/4	22 / 10
1	6.00 / 152	9.00 / 229	–	6.75 / 171	1	1-1/4	1/4	25 / 11.4
1-1/4	6.00 / 152	9.13 / 232	–	7.00 / 178	1	1-1/4	1/4	28 / 12.7
1-1/2	7.25 / 184	11.69 / 297	–	8.13 / 207	1	1-1/2	1/4	44 / 20
2	8.13 / 206	13.69 / 348	–	8.50 / 216	1	2	1/4	47 / 21.3
2-1/2	9.38 / 238	14.38 / 365	3.50 / 89	10 / 254	1	2	1/4	89 / 40
3	11.00 / 281	15.94 / 405	3.50 / 89	11.38 / 289	1-1/4	2-1/2	1/4	107 / 48

Dimensions - Model T Flanged (Cast Iron) – (in/mm)

Pipe Size	A	B	C	D	J - NPT Drains		NPT Vent	Weight (lb/kg)
					Regular	Optional		
2	10.50 / 267	13.75 / 349	–	8.50 / 216	1	2	1/4	59 / 27
3	14.00 / 356	16.00 / 406	3.50 / 89	11.38 / 289	1-1/4	2-1/2	1/4	130 / 59
4	15.88 / 403	19.38 / 492	5.00 / 127	14.06 / 357	1-1/4	2-1/2	1/4	195 / 88.6

Note: Threaded ends, NPT, Material ASTM A-278. Flanged ends, 125 lb ANSI flat face and drilling, Material ASTM A-278

* Please contact your responsible Eaton Area Sales Manager for exact Dimensions

For more information:

WEB: FLTR.com.au PHONE: (+61) 1300 62 4020 EMAIL: info@FLTR.com.au SKYPE: Purple.Engineering



Type T Cast Gas/Liquid Separators

**Model ST & STH
Cast Iron Threaded**

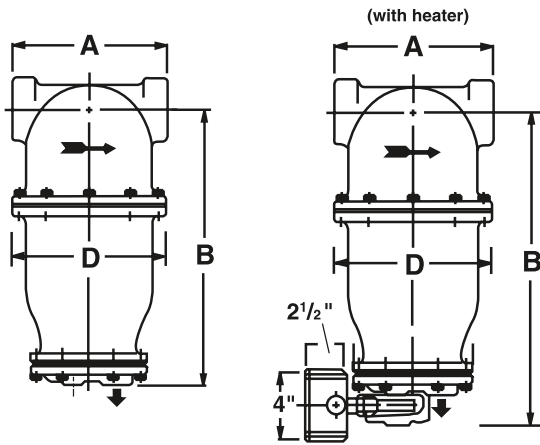

**Model ST & STH
Cast Iron Flanged**

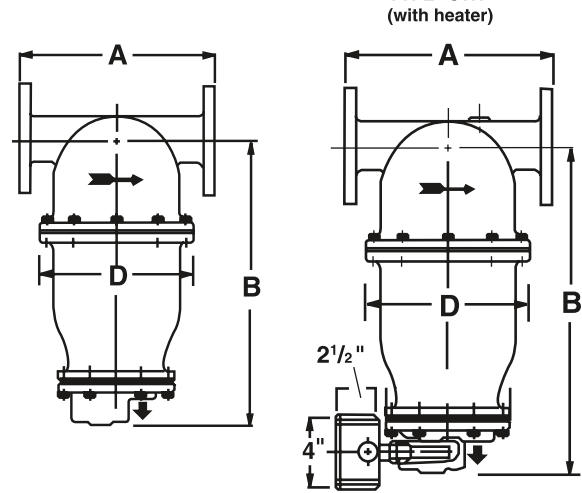

Dimensions - Model ST & STH - Threaded Inlet & Outlet (in /mm)

Pipe Size	A	B (ST)	D	Drain NPT	Vent NPT	Wt (lb/kg) ST	Wt (lb/kg) STH
3/4	5.5 / 40	11.69 / 297	6.75 / 171	3/4	1/4	31 / 14.1	31 / 14
1	6.0 / 152	10.25 / 260	6.75 / 171	3/4	1/4	39 / 17.7	41 / 18.7
1-1/4	6.0 / 152	12.25 / 311	7.00 / 178	3/4	1/4	47 / 21.3	50 / 22.3
1-1/2	7.25 / 184	14.06 / 357	8.13 / 207	3/4	1/4	53 / 24	53 / 24
2	8.13 / 206	14.94 / 380	8.50 / 216	3/4	1/4	58 / 26.3	58 / 26
2-1/2	12.00 / 305	20.44 / 520	11.38 / 289	3/4	1/4	109 / 29.5	109 / 50
3	11.00 / 280	22.44 / 570	11.38 / 289	3/4	1/4	105 / 47.7	108 / 48.7

Note: For steam service use hard valve seat only

**Model ST 3/4"
Cast Iron Threaded**

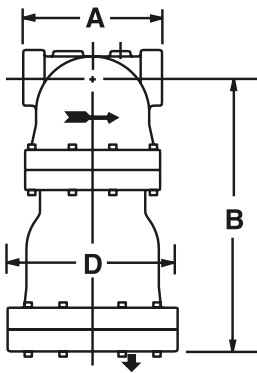

Dimensions - Model ST & STH - 125# Flanged Inlet & Outlet (in /mm)

Pipe Size	A	B (ST)	D	Drain NPT	Vent NPT	Wt (lb/kg) ST	Wt (lb/kg) STH
2	10.50 / 267	15.31 / 389	8.50 / 216	3/4	1/4	51 / 23.2	54 / 24.2
3	14.00 / 356	20.44 / 519	11.38 / 289	3/4	1/4	100 / 45.5	103 / 46.5
4	15.88 / 403	23.50 / 597	14.06 / 357	3/4	1/4	225 / 102.3	228 / 103.3

For more information:

WEB: FLTR.com.au PHONE: (+61) 1300 62 4020 EMAIL: info@FLTR.com.au SKYPE: Purple.Engineering