

FILTER UNIT, stationary with plate-exchanger
Series USP 320 PN 6

Sheet No.
4024 C

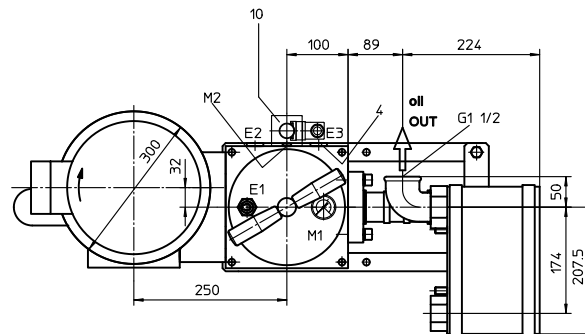
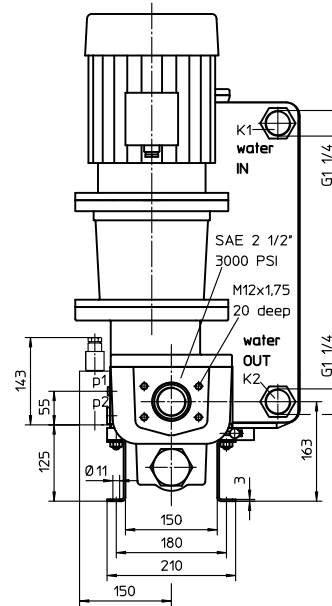
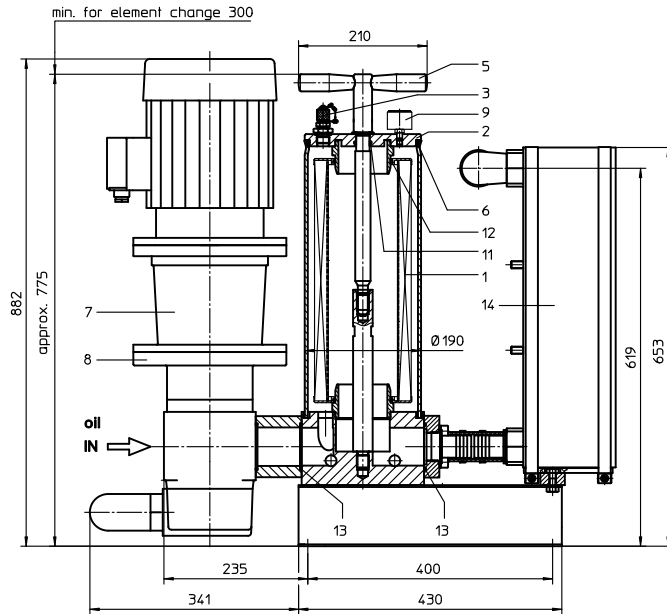

Assignment of connections and functions

- E1: venting mini-measuring connection, MA.1.St see sheet-no.1650
- E2: drainage of filter, dirt side
- E3: drainage of filter, clean side
- M1: measure connection in the housing cover, dirt side manometer 0-16 bar
- M2: measure connection at filter housing
 - p₁ = dirt side
 - p₂ = clean side
- K1: cooling water IN
- K2: cooling water OUT

1. Type index:

1.1. Filter unit: (ordering example)

USP. 320. 6VG. 10. B. P. -. P07. D07. CP30. AE

1	2	3	4	5	6	7	8	9	10	11
---	---	---	---	---	---	---	---	---	----	----

- 1 **series:**
USP = filter unit, stationary with plate-exchanger
- 2 **nominal size:** 320
- 3 **filter-material and filter-fineness:**
10 VG = 10 μm_(c), 6 VG = 7 μm_(c), 3 VG = 5 μm_(c), 1 VG = 4 μm_(c) Interpor fleece (glass fibre)
10 WVG = 10 μm_(c), 3 WVG = 5 μm_(c) Watersorp-filter element
- 4 **resistance of pressure difference for filter element:**
10 = Δp 10 bar
- 5 **filter element design:**
B = both sides open
- 6 **sealing material:**
P = Nitrile (NBR)
V = Viton (FPM), by agreement
- 7 **filter element specification:**
- = standard
VA = stainless steel
- 8 **pump unit:**
P07 = pump unit 07, NG 320.200
- 9 **motor:**
D07 = B5/132S/4.5.5.1500.400/690.D.50.1.-.- rotay current motor 400/690V, 50 Hz, approx. 1420 rpm, 5,5 kW, type of protection IP 54
- 10 **plate-exchanger unit:**
CP30 = plate-exchanger unit CP30
- 11 **clogging indicator at M2:**
- = without
AE = AE30.2.5.P.-B electrical at p₁ and p₂, 2,5 bar, see sheet-no. 1609
AOR = AOR.2.5.P.- visual, 2,5 bar, see sheet-no. 1606
AOC = AOC.2.5.P.- visual, 2,5 bar, see sheet-no. 1606

1.2. Filter element: (ordering example)

01NR. 1000. 6VG. 10. B. P. -

1	2	3	4	5	6	7
---	---	---	---	---	---	---

- 1 **series:**
01NR. = standard-return-line filter element according to DIN 24550, T4
- 2 **nominal size:** 1000
- 3 - 7 see type index-filter unit

Changes of measures and design are subject to alteration!

2. Spare parts:

item	designation	qty.	dimension	article-no.
1	filter element	1	01NR. 1000	
2	housing cover	1	22694-3	313837
3	mini-measuring connection	1	MA.1.St	305453
4	screw plug	2	G ½	304678
5	straining screw	1	31067-3	316893
6	O-ring	1	170 x 6	304799 (NBR)
7	E-motor D07	1	5,5 kW, 400/690 V	316821
8	pump unit P07	1	NG 320.200	316908
9	manometer (series)	1	∅ 40	
10	clogging indicator	1	according to type index	
11	O-ring	1	22 x 3	304387 (NBR)
12	O-ring	2	90 x 4	306941 (NBR)
13	O-ring	3	69,45 x 3,53	305868 (NBR)
14	plate-exchanger unit	1	CP30	

3. Description:

The stationary filter unit with plate-exchanger is intended for oil maintenance and for oil cooling on hydraulic systems. The area of application comprises:

- secondary flow filtration in addition to the existing operating filter and the oil cooling
- secondary flow filtration without the action of the operating filter and the oil cooling
- filtration when filling the oil reservoir.

The filter unit must not be used to pump contaminated hydraulic fluids and is therefore designed without a switchover fitting to bypass the filter. The compact structural design with plate interlacing without pipe satisfies the prerequisites for small dimensions and high reliability.

The device is equipped with a gear pump driven by an e-motor. The flow conveyed by the geared pump is fed over a filter element to DIN 24550, T4, nominal size 1000 and is led afterwards over a plate cooler.

Depending on the customer's wishes, the filter fineness is either 4, 5, 7 or 10 µm_(c).

At the measuring point M1, the working pressure before the element is shown. The pollution of the element is indicated with the clogging indicator at the measuring point M2.

At a pressure difference > 2,5 bar, the element is polluted and has to be removed with a new element.

The filter element can be changed without tools. After removing the straining screw and taking off the housing cover, the filter element is accessible and it can be exchanged. The filter elements are supplied complete with seals. Since it is not possible to clean the elements, the user must always keep an adequate supply of spare elements in stock.

To protect against overpressure, the filter unit is fitted with a safety valve, pressure setting approx. 6 bar.

The cooling capacity is shown at the cooling capacity graph for the chosen field of application, depending on the input temperature, the streams of the medium and the type of medium. The cooling capacity graph is intended for the choice of application of the suitable filter unit with cooler. For the fields of application which are not shown in the cooling capacity graph, the capacity data have to be asked for at the manufacturer.

Stationary filter units can be operated without supervision if the electrical connection is fitted with an overload protection corresponding to the current consumption of the selected e-motor and the switch-off function of the e-motor of the electrical clogging indicator will disengaged at 2,5 bar.

The line, venting and draining connections are identified according to their function. Drainage is necessary when cleaning the filter unit in connection with the change of filter element, and when setting the medium.

4. Symbols:

Filter unit with cooler without clogging indicator

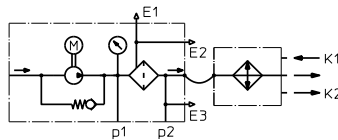

with electrical clogging indicator AE30



with visual clogging indicator AOR, AOC



5. Cooling capacity graph:

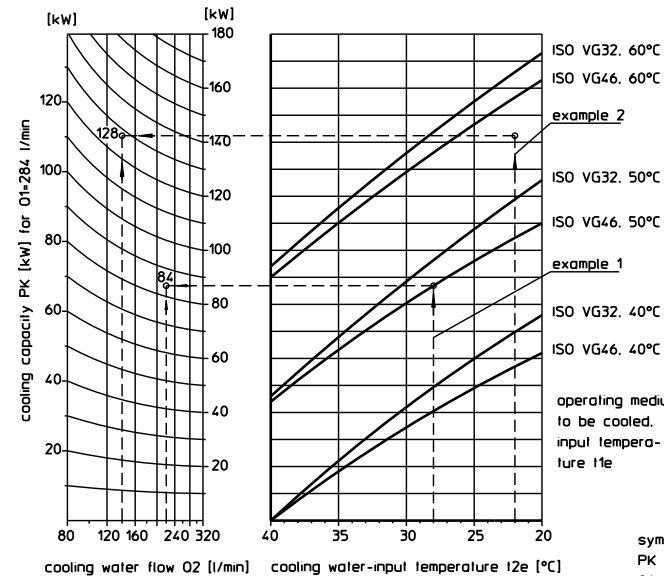

$$\text{operating medium-output temperature } I1a \text{ [}^\circ\text{C]} \quad I1a = I1e - \frac{PK * 35}{Q1}$$

$$\text{cooling water-output temperature } I2a \text{ [}^\circ\text{C]} \quad I2a = I2e + \frac{PK * 14,4}{Q2}$$

example 1. operating medium ISO VG46

$$I1e = 50 \text{ }^\circ\text{C}, \quad I2e = 28 \text{ }^\circ\text{C}, \\ Q1 = 284 \text{ l/min}, \quad Q2 = 220 \text{ l/min}$$

cooling capacity PK from the graph = 84 kW

$$I1a = 50 - \frac{84 * 35}{284} = 39,6 \text{ }^\circ\text{C}$$

$$I2a = 28 + \frac{84 * 14,4}{220} = 33,5 \text{ }^\circ\text{C}$$

example 2. operating medium ISO VG32

$$I1e = 55 \text{ }^\circ\text{C}, \quad I2e = 22 \text{ }^\circ\text{C}, \\ Q1 = 284 \text{ l/min}, \quad Q2 = 140 \text{ l/min}$$

cooling capacity PK from the graph = 128 kW (data linear interpolated)

$$I1a = 55 - \frac{128 * 35}{284} = 39,2 \text{ }^\circ\text{C}$$

$$I2a = 22 + \frac{128 * 14,4}{140} = 35,2 \text{ }^\circ\text{C}$$

symbol	units
PK	cooling capacity kW
Q1	volume flow-operating medium l/min
Q2	volume flow-cooling water l/min
I1e	operating medium-input temperature °C
I1a	operating medium-output temperature °C
I2e	cooling water-input temperature °C
I2a	cooling water-output temperature °C

6. Technical data:

pump-volume flow :	284 l/min at 1420 rpm
E-motor:	5,5 kW, approx. 1420 rpm
rotary current:	400/690 V, 50 Hz
operating pressure:	max. 6 bar
filter-fineness:	4, 5, 7 or 10 µm _(c) .
weight:	approx. 155 kg
operating medium:	hydraulic oil based on mineral oil from 10 to 100 mm ² /s, other media on request

Classified under the Pressure Vessel Directive 97/23/EC for mineral oil (fluid group 2), Article 3, Para. 3.
Classified under ATEX Directive 94/9/EC according to specific application (see questionnaire sheet-no. 34279-4).

7. Test methods:

Filter elements are tested according to the following ISO standards:

ISO 2941	Verification of collapse/burst resistance
ISO 2942	Verification of fabrication integrity
ISO 2943	Verification of material compatibility with fluids
ISO 3723	Method for end load test
ISO 3724	Verification of flow fatigue characteristics
ISO 3968	Evaluation of pressure drop versus flow characteristics
ISO 16889	Multi-pass method for evaluating filtration performance