

KU

Top Loading Single Filter Bag Housing (Bag No.1-No.2)



設計壓力 10 kgf/cm² 最大操作壓力 10 kgf/cm²
Design P. 150 psi Max Operating P. 150 psi

設計溫度 100°C 操作溫度 75°C
Design T. Operating T.

選購配件 各式濾袋、壓袋器、濾袋撐開架、金屬浮球
Accessory Filter Bag, Bag Pressing, Bag Bracket, Metal float ball

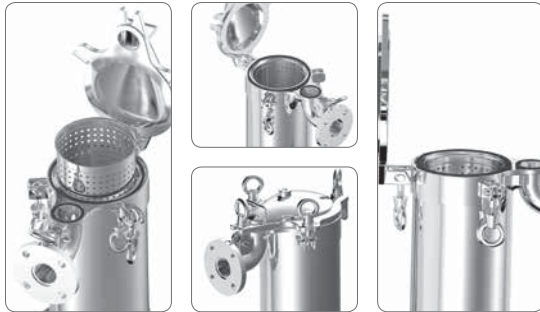

KU	2	4	SB	2	10K	E	EA
產品型號 Model	濾袋規格 Bag Size	產品材質 Material	進出口方向 Inlet & Outlet	進出口尺寸 Inlet & Outlet Size	進出口規格 Inlet & Outlet Type	O 環材質 O-ring	外 / 內表面處理 Exterior / Interior Surface Finishing
	1-Bag No.1 2-Bag No.2	4-304 6-316 6L-316L	SS- 側進側出 Side In& Side Out SB- 側進底出 Side In & Bottom Out	2-2" 221-2-1/2" 3-3"	150P-ANSI 10K-JIS PN10-DIN C-CLAMP PF-PTF NF-NPTF PM-PTM NM-NPTM	E-EPDM N-NBR V-VITON S-SILICON TS-TEFLON+SILICON	A- 酸洗 ACID-Washing E- 電解 Electrolyze P- 拋光 Polishing S- 噴砂 Sand Blasting

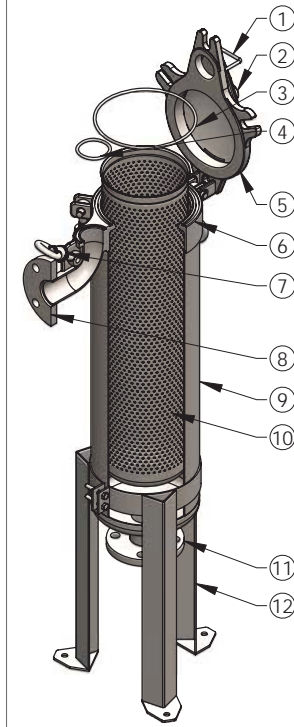

No.	Description
1	Handle
2	Vent
3	O-ring
4	O-ring
5	Top cover
6	Shell flange
7	Eye bolt
8	Port Inlet
9	Shell
10	Basket
11	Port Outlet
12	Support leg

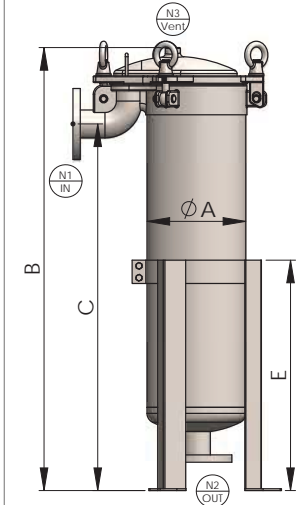
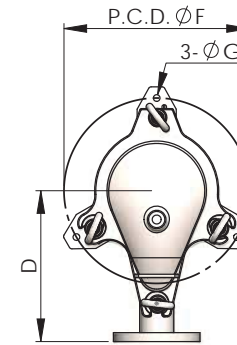

型式 Model	A m/m	B m/m	C m/m	D m/m	E m/m	F(PCD) m/m	G m/m	流量 M ³ /Hr	流量(加侖) GPM	重量 Weight	容量 Volume
KU1	Ø216	555	390	270	515	Ø310	Ø12	20	90	40kg	16L
KU2	Ø216	905	740	270	515	Ø310	Ø12	45	200	48kg	31L