

REVISIONS				
REV.	ZONE	DESCRIPTION	DATE	INITIAL
1	7D	ADDED NOTE 1.	10/17/14	M.S.

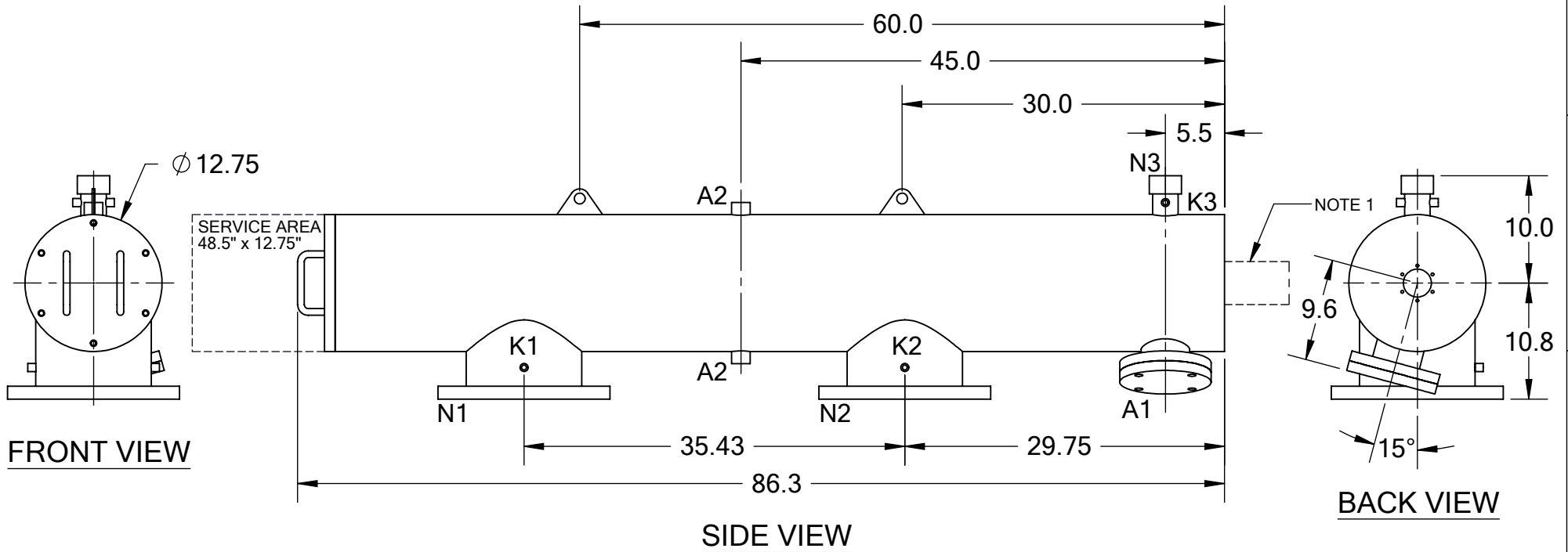



TECHNICAL DATA

FLOW RATE	MAX. 1,500 GPM (341 m ³ /hr)
SCREEN SIZE	___ MICRON
SCREEN AREA	8.0 SQ. FEET
DESIGN TEMPERATURE	160 °F
DESIGN PRESSURE	150 PSI
EMPTY WEIGHT	~385 LBS.
FULL WEIGHT	~685 LBS.

NOTES:

- PLEASE ALLOW ~20" ADDITIONAL TO INSTALL AND REMOVE THE PISTON ASSEMBLY TO THE BACKSIDE OF THE FILTER.

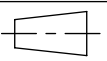
NOZZLE	CONNECTION	TYPE	SIZE	RATING	TOLERANCES (UNLESS OTHERWISE SPECIFIED)		
A1	SERVICE PORT	FLANGED	3.5" ASA	CL. #150 F.F. w/ Blind	FRAC. ±1/16	ANGLE ±1°	
A2	PRESSURE RELEASE	THREADED	1" NPT(2)		.X ±.1		DRAWN BY: S. PERKINSON DATE: 11/08/12 SCALE: 1:14
K1	HIGH PRESSURE CONN.	THREADED	1/4" NPT(2)		.XX ±.05		
K2	LOW PRESSURE CONN.	THREADED	1/4" NPT(2)		.XXX ±.010		
K3	HYDRAULIC CONN.	THREADED	1/4" NPT(2)		MATERIAL: SST		
N1	INLET	FLANGED	10" ASA	CLASS #150 F.F.S.O.	DRAWN BY: S. PERKINSON		
N2	OUTLET	FLANGED	10" ASA	CLASS #150 F.F.S.O.	DATE: 11/08/12		
N3	FLUSH OUTLET	THREADED	2" NPT		SCALE: 1:14		
					SHEET: 1 OF 1		