

REVISIONS				
REV.	ZONE	DESCRIPTION	DATE	INITIAL
1	1B, 2B	CHANGED TEMPERATURE FROM 200°F TO 160°F, PRESSURE FROM 150 PSI TO 90 PSI, & WORDING FROM "WORKING" TO "DESIGN".	08/01/12	S.P.
2	7D	ADDED NOTE 1.	10/17/14	M.S.

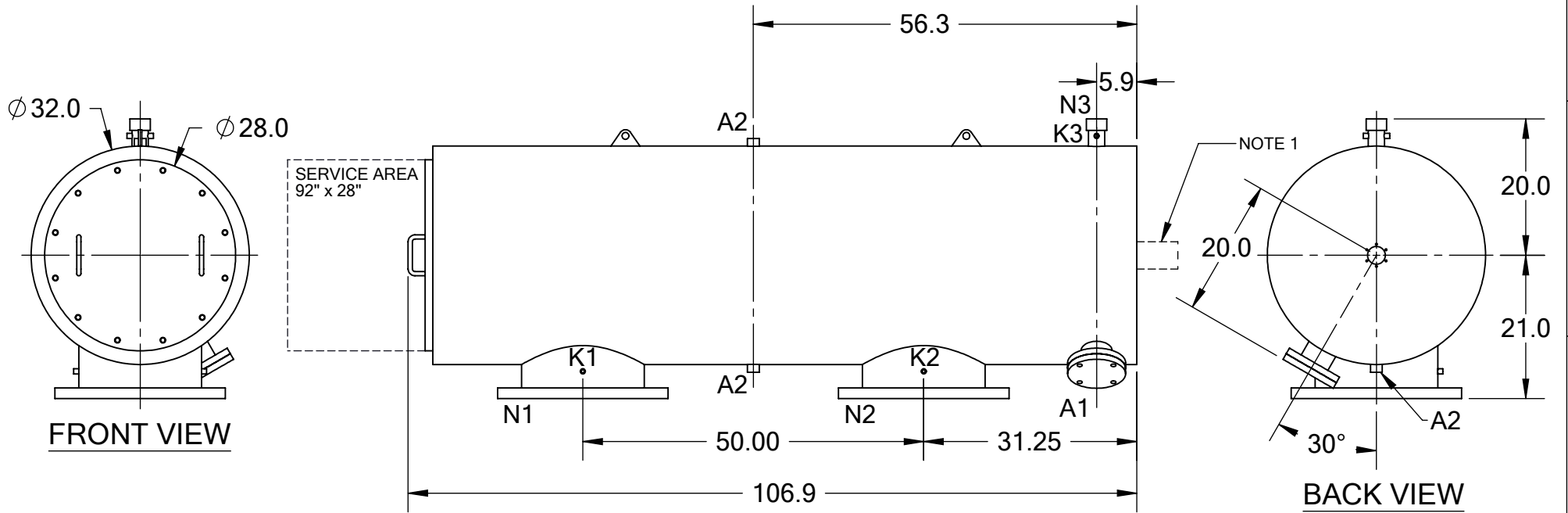



TECHNICAL DATA

FLOW RATE	MAX. 10,000 GPM (2,271 m ³ /hr)
SCREEN SIZE	___ MICRON
SCREEN AREA	24.0 SQ. FEET
DESIGN TEMPERATURE	160 °F
DESIGN PRESSURE	90 PSI
EMPTY WEIGHT	~2,100 LBS.
FULL WEIGHT	~5,100 LBS.

SIDE VIEW

NOTES:

- PLEASE ALLOW ~20" ADDITIONAL TO INSTALL AND REMOVE THE PISTON ASSEMBLY TO THE BACKSIDE OF THE FILTER.

NOZZLE	CONNECTION	TYPE	SIZE	RATING	TOLERANCES (UNLESS OTHERWISE SPECIFIED)		
A1	SERVICE PORT	FLANGED	3.5" ASA	CL. #150 F.F. w/ Blind	FRAC. ±1/16	ANGLE ±1°	
A2	PRESSURE RELEASE	THREADED	1" NPT(3)		.X ±.1		DRAWN BY: S. PERKINSON DATE: 09/26/11 SCALE: 1:22
K1	HIGH PRESSURE CONN.	THREADED	1/4" NPT(2)		.XX ±.05		
K2	LOW PRESSURE CONN.	THREADED	1/4" NPT(2)		.XXX ±.010		REV 2
K3	HYDRAULIC CONN.	THREADED	1/4" NPT(2)				
N1	INLET	FLANGED	18" ASA	CLASS #150 F.F.S.O.	MATERIAL: SST		
N2	OUTLET	FLANGED	18" ASA	CLASS #150 F.F.S.O.	DRAWN BY: S. PERKINSON		
N3	FLUSH OUTLET	THREADED	2" NPT		DATE: 09/26/11		
					SCALE: 1:22		SHEET: 1 OF 1