

| REVISIONS | | | | |
|-----------|------|---------------|----------|---------|
| REV. | ZONE | DESCRIPTION | DATE | INITIAL |
| 1 | 7D | ADDED NOTE 1. | 10/17/14 | M.S. |

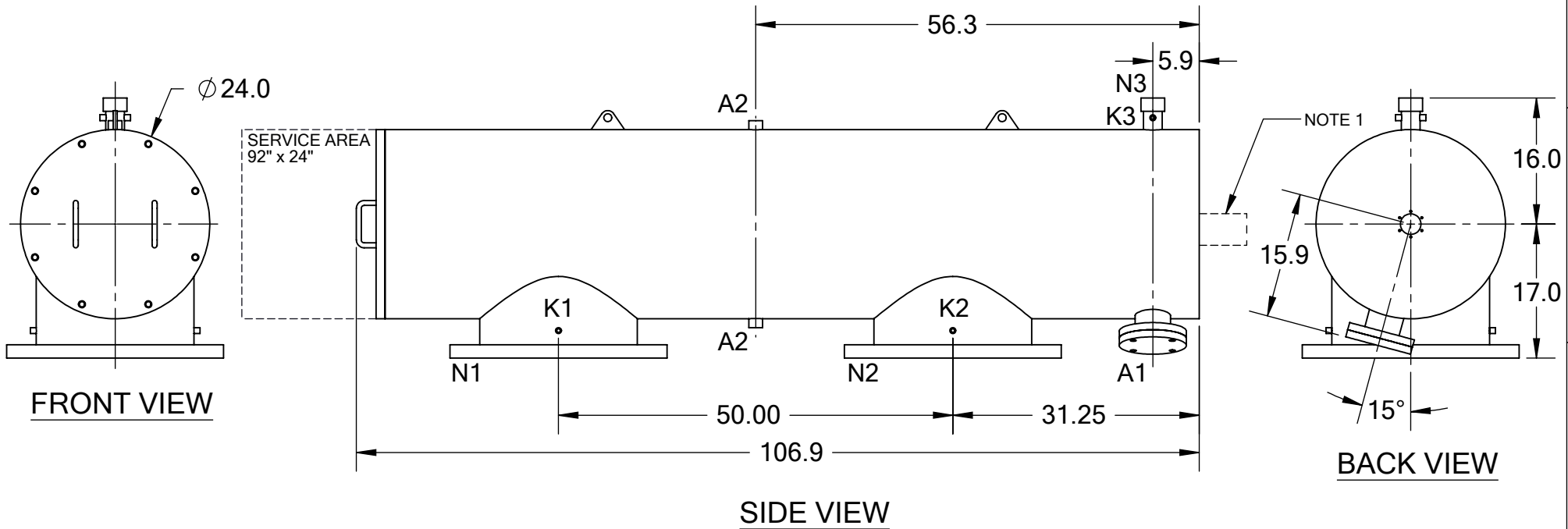

| TECHNICAL DATA | |
|--------------------|-------------------------------------------|
| FLOW RATE | MAX. 6,000 GPM (1,363 m ³ /hr) |
| SCREEN SIZE | ___ MICRON |
| SCREEN AREA | 16.0 SQ. FEET |
| DESIGN TEMPERATURE | 160 °F |
| DESIGN PRESSURE | 150 PSI |
| EMPTY WEIGHT | ~1,500 LBS. |
| FULL WEIGHT | ~2,300 LBS. |

NOTES:
 1. PLEASE ALLOW ~20" ADDITIONAL TO INSTALL AND REMOVE THE PISTON ASSEMBLY TO THE BACKSIDE OF THE FILTER.

| NOZZLE | CONNECTION | TYPE | SIZE |
|--------|---------------------|----------|-------------|
| A1 | SERVICE PORT | FLANGED | 3.5" ASA |
| A2 | PRESSURE RELEASE | THREADED | 1" NPT(2) |
| K1 | HIGH PRESSURE CONN. | THREADED | 1/4" NPT(2) |
| K2 | LOW PRESSURE CONN. | THREADED | 1/4" NPT(2) |
| K3 | HYDRAULIC CONN. | THREADED | 1/4" NPT(2) |
| N1 | INLET | FLANGED | 20" ASA |
| N2 | OUTLET | FLANGED | 20" ASA |
| N3 | FLUSH OUTLET | THREADED | 2" NPT |

| RATING | | TOLERANCES (UNLESS OTHERWISE SPECIFIED) | |
|------------------------|--|-----------------------------------------|-----------|
| CL. #150 F.F. w/ Blind | | FRAC. ±1/16 | ANGLE ±1° |
| | | .X ±.1 | |
| | | .XX ±.05 | |
| | | .XXX ±.010 | |
| MATERIAL: SST | | DRAWN BY: S. PERKINSON | |
| DATE: 04/22/13 | | SCALE: 1:19 SHEET: 1 OF 1 | |
| CLASS #150 F.F.S.O. | | CLASS #150 F.F.S.O. | |



FLTR
Purple Engineering

TITLE:
ABW20-LP FILTER, CUT DRAWING

DRAWING NUMBER: ABW-20LP-CUT-01

REV: 1