

LPF
USERS'
MANUAL

Tekleen

Check List for Optimal Filter Performance

- There should be no back-pressure on the flush line. A 1" valve should have a 2" waste line, and a 1.5" or 2" valve should have a 3" waste line. Do not use rubber hosing or flexible tubing for the waste line.
- The differential pressure gauge should be mounted within 3 feet of the filter. Long tubing lines will result in faulty gauge readings.
- The water supply line to the piston should be connected to an external water source, via a solenoid valve, and filtered by a 1/4" mini filter.
- The fitting on the side of all pistons is for venting only. It should be open to atmospheric pressure and pointing toward the ground.
- Sealant should be applied on the contact points on the backside of the D/P gauge to protect it from water. The D/P gauge should be mounted such that the blue fitting is closest to the ground to prevent shorting of the contact points in the event of a water leak.
- If the filter outlet discharges to a tank, or to open atmosphere, a valve should be installed at the filter outlet to maintain a minimum working pressure of 15 PSI during the cleaning cycle.
- If the flush valve fails to open or close, verify the connections to the controller are wired correctly (see diagram on pg.18).
- A surge protector should be installed before the electronic controller.
- It is recommended that a pressure gauge be installed on the inlet of the filter.
- The filter should be oriented so that the unfiltered media source is directed to the inlet, the manifold closest to the cover. The outlet, the manifold closest to the flush line is the source of filtered media.

For more information:

WEB: FLTR.com.au PHONE: (+61) 1300 62 4020 EMAIL: info@FLTR.com.au SKYPE: Purple.Engineering



Table of Contents

<u>SECTION I INTRODUCTION</u>		
1.1	Description	1
1.2	Theory of Operation	1
1.3	Recommended Applications	2
1.4	Design Features	2
1.5	Filter Specification Chart	3
<u>SECTION II INSTALLATION AND HOOK-UP</u>		
2.1	Mechanical Hook-Up and Orientation	4
2.2	Plumbing Hook-Up	4
2.3	Piston, Electric Ball Valve Installation, & Solenoid Valve Installation	5
2.4	GB6, D/P Gauge, Electric Ball Valve, & Solenoid Valve Connections	5
<u>SECTION III OPERATION AND ADJUSTMENTS</u>		
3.1	Start-up	6
3.2	Cleaning Cycle Requirements	7
<u>SECTION IV MAINTENANCE</u>		
4.1	Shutdown Procedure	8
4.2	Filter Cleaning	9
4.3	Dirt Collector Replacement	9
4.4	Piston Removal/Replacement	9
4.5	Motor Removal/Replacement	10
4.6	Periodic Inspection	11
<u>SECTION V TROUBLESHOOTING GUIDE</u>		
5.1	Excessive pressure drop through filter without flushing	10
5.2	Frequent or continuous flushing while filling main pipeline	11
5.3	Frequent flushing during normal operation	12
5.4	Screen Will Not Clean Properly	12
<u>SECTION VI SPARE PARTS</u>		
6.1	Recommended Spare Parts	12
6.2	Spare Parts List	12
<u>APPENDICES</u>		
Appendix I	Special Installation	13
Appendix II	Alternate Flushing Methods	13
Appendix III	Piston	14
<u>ILLUSTRATIONS</u>		
	LPF Cutaway	16
	LPF with GB6	17
	LPF Wiring Diagram Motor Drive	18
	2 x LPF with GB7	19
	2 x LPF Wiring Diagram Motor Drive	20
	Particulate Removal Process	21
	Pressure Drop vs. Screen Size	22
<u>WARRANTY</u>		
		23

For more information:

WEB: FLTR.com.au PHONE: (+61) 1300 62 4020 EMAIL: info@FLTR.com.au SKYPE: Purple.Engineering



SECTION I INTRODUCTION

1.1 Description

The LPF series models (Low Pressure Filter) are automatic, self cleaning screen type water filters. The filtration system consists of a tank body, a first stage coarse screen, a second stage fine screen, an electric motor, a flushing valve, a solenoid valve, and an electronic controller.

1.2 Theory of Operation

Pressurized water enters the filter inlet and travels through a 3/8" perforated stainless steel coarse screen (1/4" for smaller models) where large particles are pre-filtered. The water then passes through a fine mesh stainless steel screen where small contaminants (down to 10 microns in size) are filtered out. The clean water then exits through the outlet of the filter.

When the fine screen becomes contaminated, a pressure differential is sensed causing the automatic controller to open the flushing valve and start the electric motor. When the flush valve opens, an atmospheric pressure path is established, causing the clean water to reverse flow at the point of suction across the filter element. This process removes contaminants from the screen, sending the dirty water through the nozzles and the dirt collector mechanism and out the flush valve.

As the electric motor rotates the dirt collector, water passes through the nozzles, thus vacuuming the entire surface area of the filter element.

When the screen is clean, the unit automatically closes the electric valve, returning the filter to normal operation.

The entire cleaning cycle takes approximately 10-15 seconds. It should be noted that even during the flush cycle, the filtration process continues uninterrupted.

1.3 Recommended Applications

Tekleen filters are ideal for filtering out silt, scale, sand, rust, dirt and organic material like algae, zebra mussels, and clams from virtually all types of water sources.

1.4 Design Features

Among the many features of the LPF models is an avoidance of forcing contaminated water back into the system, which often happens with sand media filters. LPF filters will deliver clean water or no water at all.

The most predominant feature is its ability to remove organics such as algae and other suspended particles.

All filter internal elements can be removed and disassembled from the filter body without disruption of the plumbing.

The backwash cycle, Tekrinse, uses 90% less rinse water than other filters on the market today.

For special constructions and applications, see Appendix I, page 12.

For more information:

WEB: FLTR.com.au **PHONE:** (+61) 1300 62 4020 **EMAIL:** info@FLTR.com.au **SKYPE:** Purple.Engineering



1.5 Filter Specifications Chart

Model	Flange Size	Screen Area	Max. Flow	Empty Weight	Service Area
	Inch	Sq. Ft.	GPM	Lbs.	Inch
LPF2-L	2	0.5	130	120	7
LPF2-LP	2	0.5	130	120	7
LPF2-S	2	1.4	200	150	13
LPF2-SP	2	1.4	200	150	13
LPF2-XLP	2	2.5	300	225	20
LPF3	3	0.5	150	125	7
LPF3-S	3	1.4	200	150	13
LPF3-SP	3	1.4	200	150	13
LPF3-LP	3	2.5	300	250	20
LPF4	4	1.4	300	170	13
LPF4-P	4	1.4	300	170	13
LPF4-LPE	4	2.5	400	250	20
LPF4-L	4	5	600	230	35
LPF4-LP	4	5	600	280	35
LPF4-XLP	4	8	800	325	49
LPF4-SP	4	7	1,000	525	62
LPF6-P	6	2.5	600	260	20
LPF6-L	6	5	800	280	35
LPF6-LP	6	5	800	300	35
LPF6-XLP	6	8	800	335	49
LPF6-TXLP	6	16	1,500	900	49
LPF6-SP	6	7	1,750	535	62
LPF8	8	5	1,320	400	35
LPF8-P	8	5	1,320	340	35
LPF8-LP	8	8	1,500	360	49
LPF8-SP	8	7	1,750	560	62
LPF8-TLP	8	16	2,500	1,000	49
LPF10	10	7	1,750	500	62
LPF10-P	10	7	1,750	585	62
LPF10-SP	10	8	1,500	385	49
LPF10-LP	10	11	2,630	650	92
LPF10-XLP	10	16	6,000	1,300	92
LPF12	12	11	2,630	650	92
LPF12-P	12	11	2,630	690	92
LPF12-LP	12	12.5	4,000	850	92
LPF12-XLP	12	16	6,000	1,300	92
LPF14	14	12.5	4,000	800	92
LPF14-P	14	12.5	4,000	900	92
LPF14-LP	14	16	6,000	1,350	92
LPF16-P	16	12.5	4,000	900	92
LPF16-LP	16	16	6,000	1,400	92
LPF16-L	16	16	6,000	1,000	92
LPF16-SP	16	24	10,000	2,100	92
LPF18-LP	18	16	6,000	1,450	92
LPF18-TP	18	25	8,000	2,000	92
LPF18-SP	18	24	10,000	2,100	92
LPF20-TP	20	25	8,500	2,100	92
LPF20-SP	20	24	10,000	2,200	92
LPF20-TLP	20	32	12,000	2,800	92
LPF24-SP	24	24	10,000	2,500	92
LPF24-TLP	24	32	20,000	2,900	92
LPF30-TSP	30	48	30,000	4,200	92
LPF36-TSP	36	48	30,000	5,000	92

For more information:

WEB: FLTR.com.au PHONE: (+61) 1300 62 4020 EMAIL: info@FLTR.com.au SKYPE: Purple.Engineering



SECTION II INSTALLATION AND HOOK-UP

2.1 Mechanical Hook-Up and Orientation

The positioning of the filter tank should be determined by the disposal of waste water and to allow easy access and removal of the filter element (see Filter Specifications Chart for the required service area). The Tekleen filter can rest on the inlet and outlet flanges or can be mounted on a stand if desired. In fact, the filter can be mounted in any position (vertical, upside down, etc.). The electronic controller should be mounted in close proximity to the filter housing.

2.2 Plumbing Hook-Up

The waste discharge pipe should be at least one inch larger in diameter than the size of the flush valve (1" valve to 2" pipe & 2" valve to 3" pipe). The waste pipe should be kept as short as possible with no more than one elbow. This will minimize back pressure on the flush line.

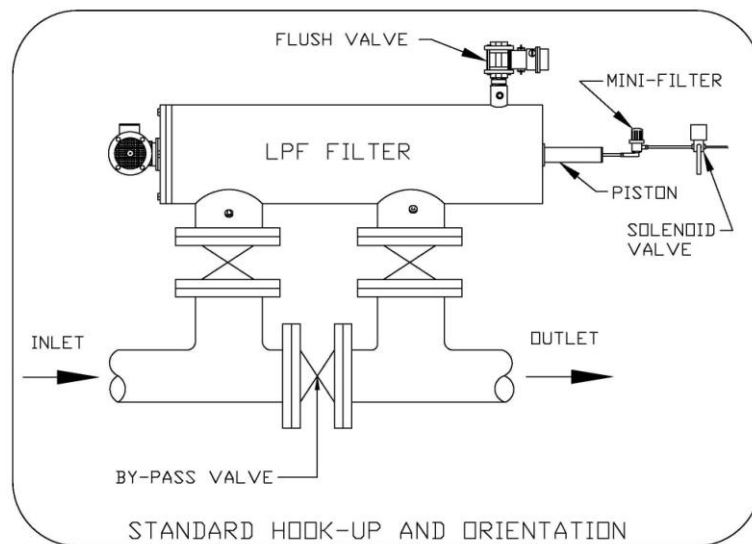

Flush lines should not be elevated. This will affect the pressure difference required for the cleaning cycle. If it is necessary to run flush lines uphill, please consult with the manufacturer.

Flush line pipe must be ridged. It should not be made out of flexible tube or rubber hosing. Any restrictions in the flush line will reduce the cleaning ability of the filter.

An isolation valve should be installed at the inlet of the filter. During start-up, the isolation valve should be only slightly open to prevent a surge of pressure across the filter when the pump is started. Once the pump is on-line, slowly open the isolation valve. This will prevent any possible damage to the filter due to a pressure surge.

2.3 Piston, Electric Ball Valve Installation, & Solenoid Valve Installation

1. PISTON: To install the piston first install the provided hardware and gasket onto the back end of the filter. Apply lubricant to the O-ring that will be mating to the filter to prevent pinching. Proceed to remove the PVC housing from the piston. Using the studs that were installed, mate the piston head to the filter with the piston indicating pin pointing towards the ground. When complete, reattachment of the PVC piping is optional.

2. EBV: Prior to installing an electric ball valve, apply PTFE (Teflon) thread sealant to all threads. Do NOT tighten ball valve to filter via the plastic housing as it may damage the electrical components of the actuator.

3. SOLENOID VALVE: Install the provided fittings onto Port 2 and Port 3. Port 2 will be connected to your city water supply. Port 3 will be the vent for the spent water, this fitting is provided to redirect the water via tubing to a more convenient location. Connect Port 1 directly to the pre-installed 1/8" SST Nipple on the piston end.

2.4 GB6, D/P Gauge, Electric Ball Valve, & Solenoid Valve Connections

Before power is applied to the electronic controller, make all connections between the controller, D/P Gauge, electric ball valve, and solenoid valve (see page18).

1. BALL VALVE: Plug controller into appropriate power source. Connect the ball valve to the controller as shown in the wiring diagram (page18). Activate the manual start switch on the GB6 controller and visually inspect the open and close movement of the ball valve.

2. FLUSHING TIME ADJUSTMENT: The flush time is normally set to 10 seconds. Flush time should be adjusted to allow the piston indicator pin to reach the end of the slot during one backwash cycle. NOTE: Excessive flush time will not improve cleaning, and may lead to unnecessary wear and tear on filter equipment.

3. PRESSURE DIFFERENTIAL ADJUSTMENT: The differential switch is preset for 7 PSI. It can be changed to different set points (see your electronic controller manual).

USING 1/4 INCH DIAMETER TUBING

1. Attach tubing to the low pressure 1/4" fitting on the outlet flange. If the system contains more than one filter, attach tubing to the outlet manifold directly. Attach the other end of the tubing to the fitting on the D/P switch marked "low" pressure.

2. Attach tubing to the high pressure 1/4" fitting on the inlet flange. If the system contains more than one filter, attach tubing to the inlet manifold directly. Attach the other end of the tubing to the fitting on the D/P switch marked "high" pressure.

Notes: Do not run tubing more than three feet in length. Doing so will cause a pressure drop across the tubing, which may cause the electronic controller to operate improperly.

3. Attach tubing to Port 2 of the solenoid valve. Attach the other end of the tubing to your city water supply. The mini-filter should be added to this ¼" line to prevent larger debris particles from plugging the solenoid. Tubing may be added to Port 3 to redirect the vented water to a more convenient location.

SECTION III OPERATION AND ADJUSTMENTS

3.1 Start-Up

During start-up, the isolation valve at the filter inlet should be only partially open to prevent a surge of pressure across the filter when the pump is started. Once the pump is on-line, slowly open the isolation valve. This will prevent any possible damage to the filter due to a pressure surge.

Do not proceed until the tasks above have been completed

During the initial filling of the main pipeline, there may not be enough back-pressure downstream from the filter to allow the cleaning cycle to function properly. Therefore, it is necessary to install a valve at the outlet to be partially closed (i.e., gate valve, ball valve or butterfly valve).

If a downstream main line valve is partially closed, enough to provide 15 PSI at the filter inlet pressure gauge, the self cleaning cycle will operate properly. Once the total system is fully charged, the downstream valve can be adjusted, as long as 15 PSI is maintained at the filter inlet during the cleaning cycle.

Do not proceed until the tasks above have been completed

In applications where the main flow to the filter is intentionally interrupted and the line is drained, it is advisable to install a flow control or pressure sustaining valve downstream from the filter. This will create back pressure on the filter in order to enable proper flushing while main line pressurizes.

Once the system is fully pressurized, push the manual flush button on the electronic controller and verify that the piston is moving. For pistons with non-metal casings, a flashlight can be held up to the case, where the bottom cap of the piston can be seen, and a visual check performed to verify the piston is completing the full stroke. For metal pistons, an indicating pin is located underneath the piston cover sleeve and can be checked to verify the full stroke of the piston is obtained. Also during this manual flush, verify that the flush valve is opening all the way. During the first cleaning cycle, air in the system will be expelled, so it may require more than one cycle to achieve proper cleaning.

Do not proceed until the tasks above have been completed

For more information:

WEB: FLTR.com.au **PHONE:** (+61) 1300 62 4020 **EMAIL:** info@FLTR.com.au **SKYPE:** Purple.Engineering



3.2 Cleaning Cycle Requirements

WORKING PRESSURE

The filter requires a minimum pressure of 15 PSI at the inlet during the cleaning cycle for effective cleaning.

Maintaining the necessary minimum working pressure during the cleaning cycle requires a pump with sufficient capacity. Pump selection will depend on three key parameters: the required working pressure (15 PSI), the process flow of the system, and the flush flow of the filter.

PROCESS FLOW

Process flow is the volumetric rate of water that will pass through the filter during normal operation (when the filter is not in a cleaning cycle).

FLUSH FLOW

The flush flow is the volumetric rate of water that will be used during a cleaning cycle. This rate depends on the size of the flush valve used.

FLUSH VALVE SIZE		FLUSH FLOW	
inch	mm	gpm	m ³ /hr
1"	DN25	60-80	14-18
1.5"	DN40	120-160	27-36
2"	DN50	240-320	55-73

To determine if a pump will satisfy the performance needs of your system, add the process flow of the system to the flush flow of the filter to find the total flow.

Process Flow + Flush Flow = Total Flow

Consult the pump curve provided by the pump manufacturer to determine if it meets the performance requirements. The pump curve describes the performance of the pump in terms of flow and pressure. Locate your total flow on the graph to determine what pressure will be maintained at that flow. If the pressure is greater than 15 PSI, then the pump satisfies the requirements.

For more information:

WEB: FLTR.com.au PHONE: (+61) 1300 62 4020 EMAIL: info@FLTR.com.au SKYPE: Purple.Engineering



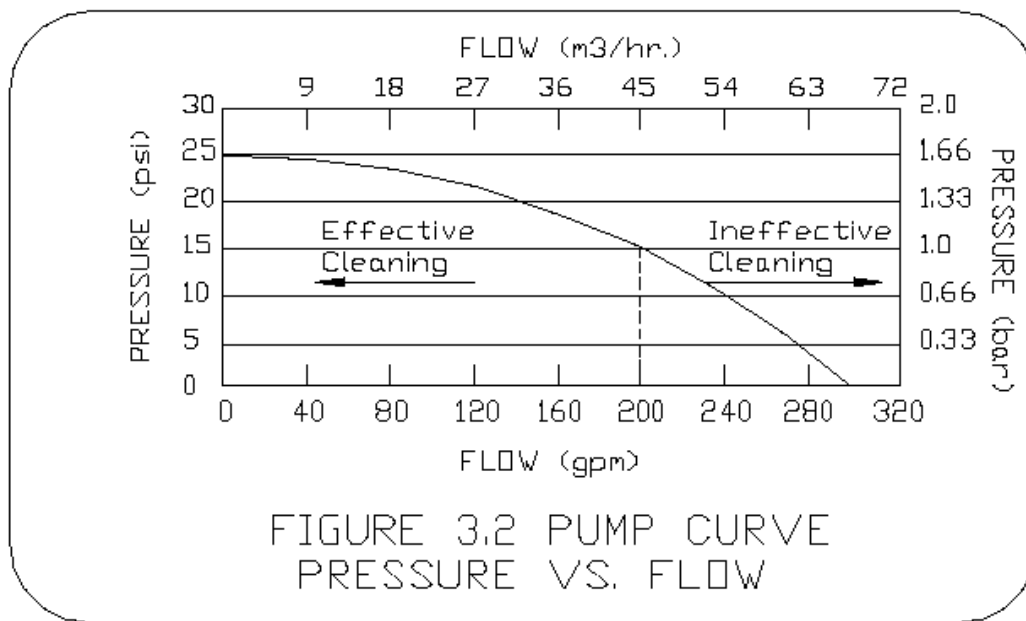

Figure 3.2 shows an example of a pump curve. Since a minimum of 15 PSI must be maintained, the critical point for this pump is at 200 gpm. Any flow greater than this will not yield effective cleaning during the backwash cycle.

If, for example, the process flow were to be 190 gpm and the flush flow 40 gpm, the total flow would be 230 gpm. This would produce an inlet pressure less than the required 15 PSI and as a result the filter would not be able to perform an effective cleaning cycle.

If the process flow were to be 150 gpm with a flush flow of 40 gpm, the total flow would be 190 gpm. This would produce an inlet pressure greater than the required 15 PSI and result in an effective cleaning cycle.

SECTION IV MAINTENANCE

4.1 Shutdown Procedure

When shutting down the filter, steps must be taken to ensure that there will be no reverse flow across the screen that may damage components. The proper shutdown sequence is as follows:

1. Open the bypass valve.
2. Close the outlet isolation valve completely.
3. Close the inlet isolation valve completely. The filter is now isolated and the system flow is bypassed.
4. Relieve any residual pressure in the filter housing by detaching the 1/4" plastic tubing from any fitting.
5. Drain the remaining water from the filter body by either:
 - a. Unscrewing the 1" NPT pressure release plug (located on the top and bottom of the filter).
 - b. Loosening the cover nuts and slightly opening the cover.

4.2 Filter Cleaning

The coarse screen is not part of the self cleaning mechanism. Therefore periodic cleaning and inspection of the coarse screen, if supplied, is necessary for removal of large particles trapped in the chamber. To do this, simply follow the shutdown procedure, and then remove the filter cover.

It is also recommended that the fine screen be inspected during coarse screen cleaning. For models with line sizes of 2"-8", remove the fine screen using a screen installer/remover tool (Figures 4.1 & 4.2). The fine screen can also be removed by reaching inside the filter and pulling out the fine screen by the screen bar.

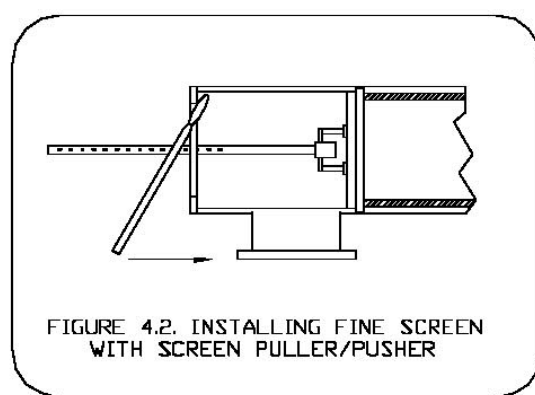
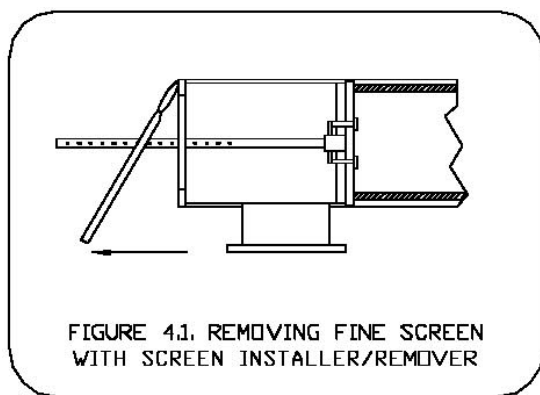

4.3 Dirt Collector Replacement

If the dirt collector should ever need replacing, follow Section 4.1 (Shutdown Procedure), Section 4.2 (Filter Cleaning) and then proceed as follows:

1. Ensure that the dirt collector is being removed along with the fine screen by pulling on the dirt collector rod.
2. Remove the dirt collector from the bottom of the fine screen.

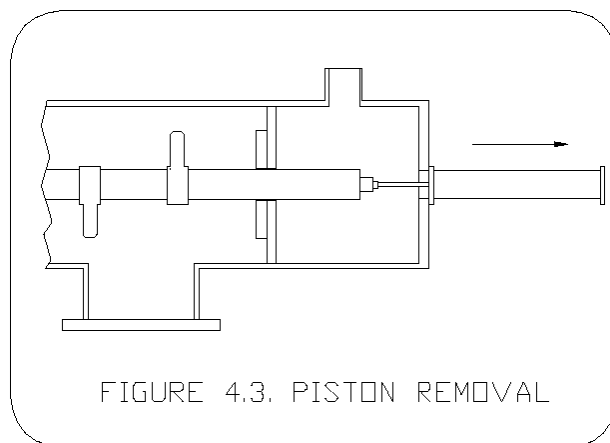

4.4 Piston Removal/Replacement

If the piston needs to be removed or replaced, follow the steps outlined and refer to Fig. 4.3:

1. Follow steps 1-5, Section 4.1

For more information:

WEB: FLTR.com.au PHONE: (+61) 1300 62 4020 EMAIL: info@FLTR.com.au SKYPE: Purple.Engineering

2. Unscrew all connection nuts where the piston is connected to the back side of the filter housing.
3. Remove piston by pulling it away from the filter housing (Figure 4.3).
4. Re-assemble unit (reverse procedure).

4.5 Motor Removal/Replacement

If the electric motor needs to be removed or replaced from the cover of the filter, follow the steps outlined as follows and refer to Fig. 4.4:

1. Follow steps 1-5, section 4.1
2. Remove the LPF cover from the filter.
3. Remove the shaft bolt securing the motor drive shaft to the dirt collector extension shaft.
4. Remove the motor drive shaft from the motor. Use a mallet to push the protruding end of the shaft out of the motor.
5. Remove the eight (8) nuts from the mounting studs, and separate the motor/bracket assembly from the cover.
6. Remove the four (4) screws underneath securing the motor to the motor bracket.
7. Re-assemble unit (reverse procedure) with the motor facing the same was as before.

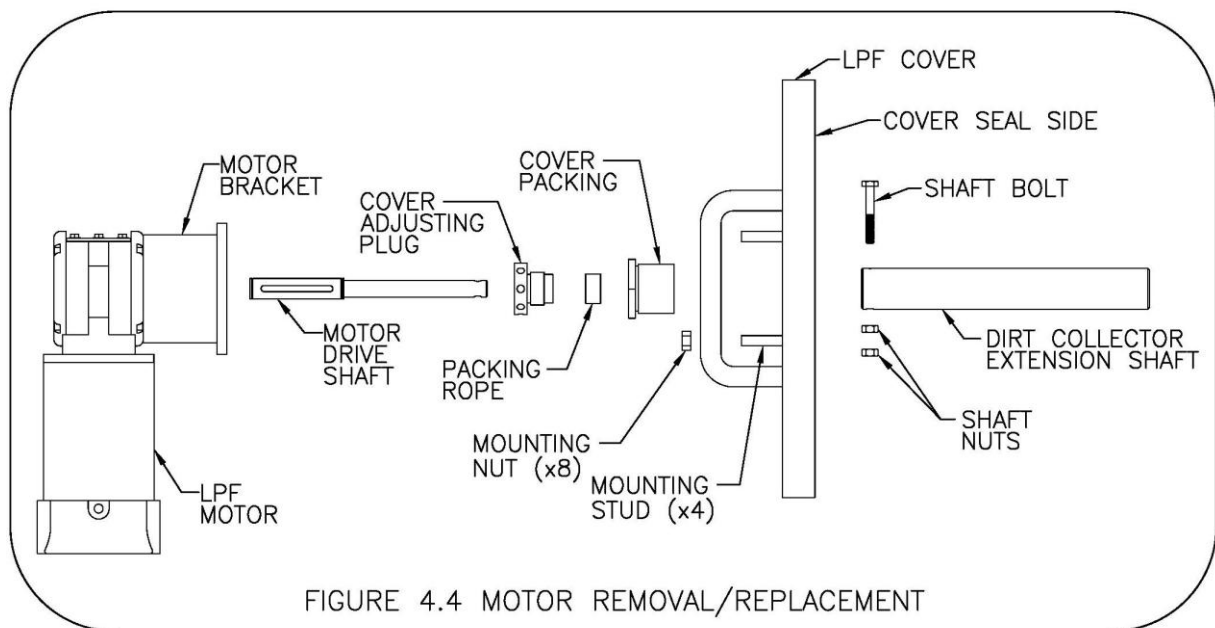

FIGURE 4.4 MOTOR REMOVAL/REPLACEMENT

For more information:

WEB: FLTR.com.au PHONE: (+61) 1300 62 4020 EMAIL: info@FLTR.com.au SKYPE: Purple.Engineering

4.6 Periodic Inspection

The following parts should be inspected annually for wear and tear and should be replaced if necessary:

- Cover Seal
- Fine Screen
- Piston
- Dirt Collector
- Lower Bearing
- Coarse Screen
- O-rings
- Packing Rope
- Upper Bearing
- Air/Water Connections

SECTION V TROUBLESHOOTING GUIDE

5.1 Problem: Excessive pressure drop through filter without flushing

POSSIBLE CAUSES

1. Controller is not turned on.
2. Flush valve is wired incorrectly.
3. Filter is installed backwards.
4. D/P switch is malfunctioning.

SOLUTIONS

1. Turn the power switch on the controller to “on”.
2. Consult the wiring diagram, and verify that the valve is connected correctly.
3. Verify correct flow direction through filter.
4. Check set point on D/P switch. Make sure ¼” black tubing is less than 3 feet in length and unobstructed. Verify that the D/P switch is connected to the appropriate fittings on the filter.

5.2 Problem: Frequent or continuous flushing while filling main pipeline

POSSIBLE CAUSES

1. Downstream pressure is not available to provide effective cleaning cycle.
2. High flow rate exceeds the D/P switch’s preset differential.
3. Filter may have been shut down while the screen is dirty, resulting in a layer of contaminant on the screen that has caked on.

SOLUTIONS

- 1&2. Partially close downstream mainline valve. Filter inlet gauge should read at least 15 PSI.
3. A “super flush” must be performed as follows: Close the outlet valve and initiate a cleaning cycle. Open the outlet valve and check the filter differential. If the differential does not return to zero, repeat the process.

5.3 Problem: Frequent flushing during normal operation

POSSIBLE CAUSE

1. Very dirty water.
2. Marginal working pressure results in poor cleaning cycle.
3. Screen may be partially plugged.
4. Dirt collector may be jammed which results in only cleaning the screen directly in front of the nozzles.

SOLUTION

1. Screen opening size may be too small for the given application. Consult manufacturer.
2. Verify the inlet pressure is at least 15 PSI during the cleaning cycle. If not, partially close the outlet valve to increase inlet pressure.
3. Perform super flush as described in section 5.2.
4. Open filter and verify the dirt collector rotates freely.

5.4 Problem: Screen will not clean properly

POSSIBLE CAUSE

1. The flush cycle duration is too short.
2. Filter was shut down dirty with contaminants caked on the screen.
3. Flush line is causing back pressure on the flush valve.
4. Piston is not operating properly.

SOLUTION

1. Increase flush duration on controller panel.
2. Perform super flush as described in section 5.2.
3. Make sure the flush line is 1" larger than the flush valve (See section 2.2).
4. Verify that the indicator pin is moving to its full stroke during the cleaning cycle. Make sure that the inlet pressure is at least 15 PSI during the cleaning cycle.

SECTION VI SPARE PARTS

6.1 Recommended Spare Parts

The following are recommended spare parts to keep in stock:

- | | |
|---------------------------|-------------------------------|
| - Fine Screen (#4) | - Set of O-rings (#16) |
| - Cover Seal (#10) | - Dirt Collector (#5) |
| - Upper Bearing (#11) | - Lower Bearing (#12) |
| - D/P Switch (#34) | - Controller Board |
| - Piston Repair Kit (#29) | - Dirt Collector Nozzles (#6) |
| - Mini-Filter (#18) | -Packing Rope (#50) |

6.2 Spare Parts List

Refer to filter cutaway on page 16.

For more information:

WEB: FLTR.com.au PHONE: (+61) 1300 62 4020 EMAIL: info@FLTR.com.au SKYPE: Purple.Engineering



APPENDICES

Appendix I Special Installation

I. AUTOMATIC BY-PASS

Sometimes it is necessary to have flow even when the filter is out of service for periodic maintenance. In this situation, it is recommended to create a by-pass.

FILTER BY-PASS

It is very simple to create a by-pass, especially for the on-line models. To do so, add an isolation valve on both the inlet and outlet and a bypass with another isolation valve (see drawing).

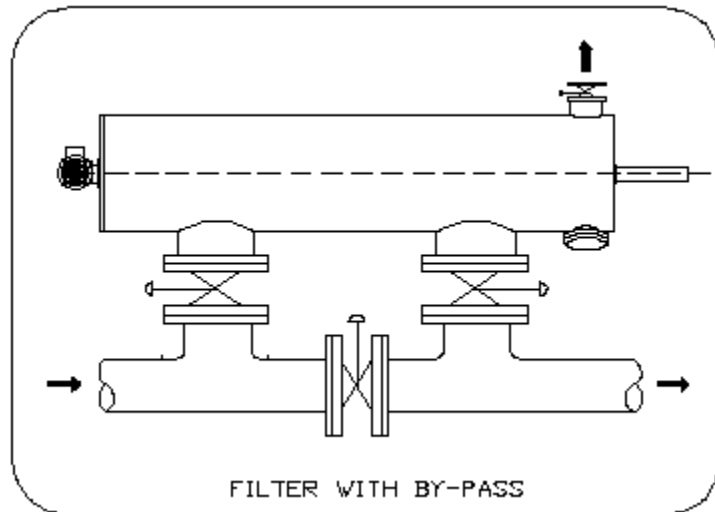

If the by-pass valve is provided with an actuator, it can be converted into an automatic by-pass system by wiring them to the controller (see controller manual).

Appendix II Alternate Flushing Methods

There are several possible solutions if there is not enough pressure and/or flow to successfully achieve a backwash. For low flow installations with pressure greater than 15 PSI, proceed as follows:

1. The easiest method is to place an automatic valve (pressure sustaining valve) at the filter outlet. The valve will close when the filter is flushing. During the cleaning cycle, there would be no water available to the system and the full pump capacity will be used for the backwash filter.

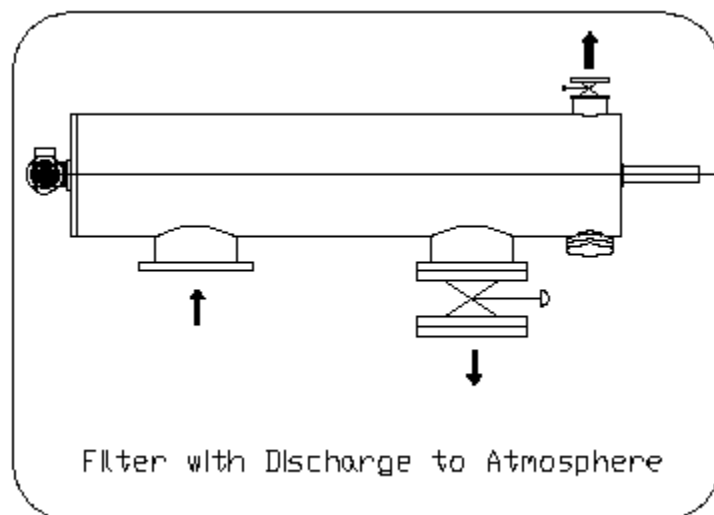

2. The required extra flow can be obtained by means of an expansion tank installed directly upstream of the filter inlet. The expansion tank would contain water at operating pressure to supply to the filter during the cleaning cycle.

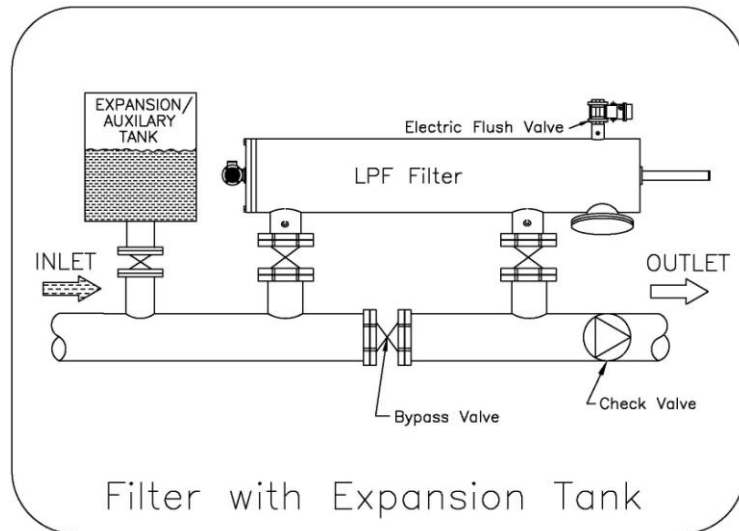

3. Another way to obtain supplemental flow is to add a water source to the inlet of the filter. The water source would be controlled with an actuated valve, opening during the cleaning cycle (see controller manual for wiring).

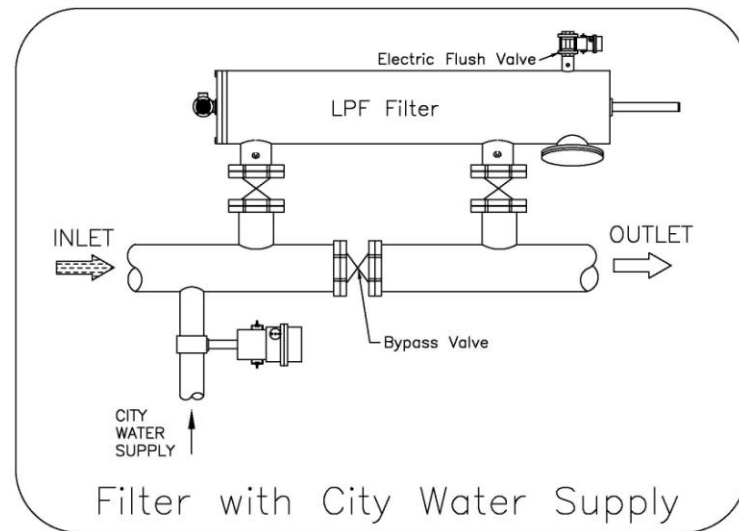

Appendix III Piston

Due to longer screens on larger filters, it is necessary to employ a piston for the cleaning mechanism. The piston is used to control the linear movement of the dirt collector during cleaning cycles. This enables the dirt collector to clean the entire surface area of the screen in a spiral-downward movement. At the end of the cleaning cycle, the flush valve closes and the solenoid valve returns to its de-energized position, thus the normal filtration process resumes. At the same time, the piston is pressurized, which pushes the dirt collector back into its original position, ready for the next cleaning cycle.

Upon initial installation of the system, all seals within the piston may not be set in place. This may lead to water leaking from the piston, which is normal. In addition to protecting the piston, the PVC cover sleeve allows water leakage to be drained to a single location. After the system has been running for some time, the seals within the piston will set and the leakage will decrease or stop completely. The cover sleeve can also be slid back to expose the bolt holes and

piston indicating pin. The piston should be installed so that the piston indicating pin is facing the ground.

Note: Some LPF models come with a different piston than what is pictured below.

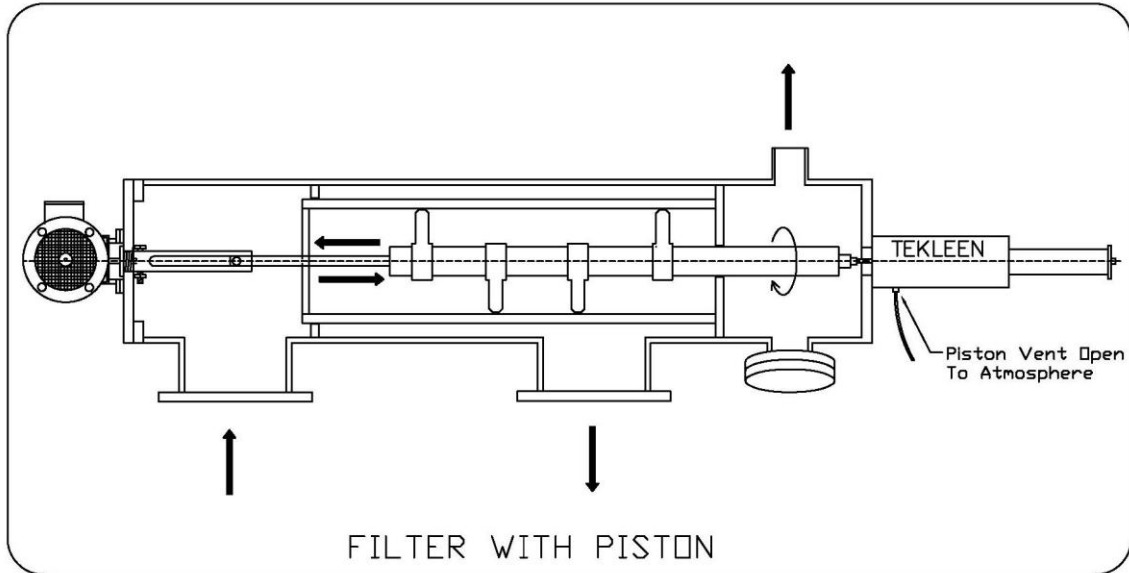

For more information:

WEB: FLTR.com.au PHONE: (+61) 1300 62 4020 EMAIL: info@FLTR.com.au SKYPE: Purple.Engineering

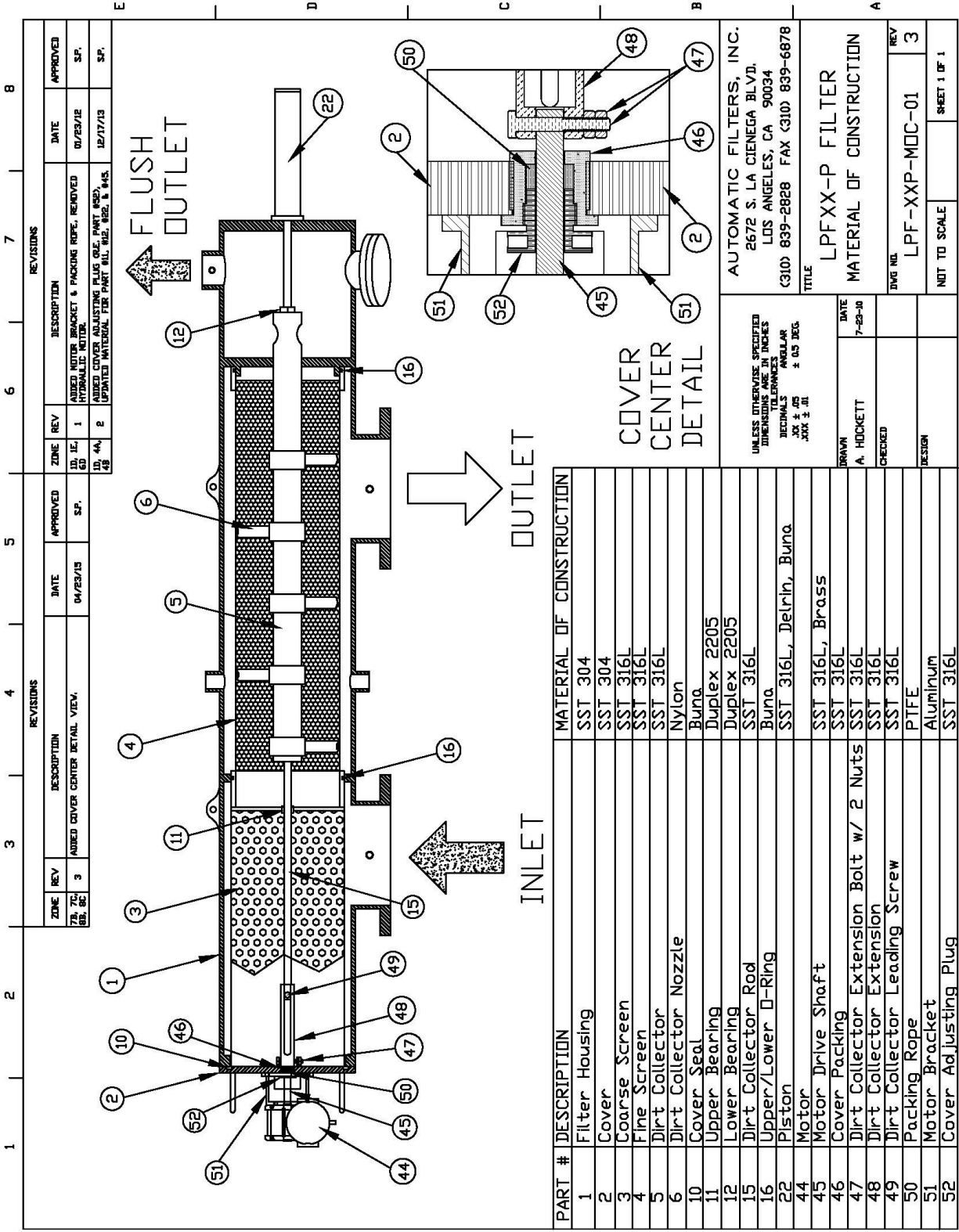

ZONE		REV	DATE	APPROVED	DESCRIPTION	ZONE	REV	DATE	APPROVED
7B, 7C, 8B, 8C	3		04/23/13	SP.	ADDED COVER CENTER DETAIL VIEW.	1D, 1E, 6D	1	04/23/13	SP.
						1D, 4A, 4B	2	12/17/13	SP.

ZONE		REV	DATE	APPROVED	DESCRIPTION
					ADDED MOTOR BRACKET & PACKING ROPE, REMOVED HYDRAULIC MOTOR.
					ADDED COVER ADJUSTING PLUG (SEE PART #52), UPDATED MATERIAL FOR PART NO. 16, 22, & 44.

PART #	DESCRIPTION	MATERIAL OF CONSTRUCTION
1	Filter Housing	SST 304
2	Cover	SST 304
3	Coarse Screen	SST 316L
4	Fine Screen	SST 316L
5	Dirt Collector	SST 316L
6	Dirt Collector Nozzle	Nylon
10	Cover Seal	Buna
11	Upper Bearing	Duplex 2205
12	Lower Bearing	Duplex 2205
15	Dirt Collector Rod	SST 316L
16	Upper/Lower O-Ring	Buna
22	Piston	SST 316L, Delrin, Buna
44	Motor	SST 316L, Brass
45	Motor Drive Shaft	SST 316L
46	Cover Packing	SST 316L
47	Dirt Collector Extension Bolt w/ 2 Nuts	SST 316L
48	Dirt Collector Extension	SST 316L
49	Dirt Collector Leading Screw	SST 316L
50	Packing Rope	PTFE
51	Motor Bracket	Aluminum
52	Cover Adjusting Plug	SST 316L

UNLESS OTHERWISE SPECIFIED
DIMENSIONS ARE IN INCHES
DECIMALS ANGULAR
TOLERANCES
XXX ± .05
XXX ± .03 DEG
XXX ± .01

AUTOMATIC FILTERS, INC.
2672 S. LA CIENEGA BLVD.
LOS ANGELES, CA 90034
(310) 839-2828 FAX (310) 839-6878

TITLE
LPFXX-P FILTER
MATERIAL OF CONSTRUCTION

DATE
7-29-10
DRAWN
A. HOCKETT
CHECKED
DESIGN

REV
LPG-XXP-MOC-01
3

NOT TO SCALE
SHEET 1 OF 1

For more information:

WEB: FLTR.com.au PHONE: (+61) 1300 62 4020 EMAIL: info@FLTR.com.au SKYPE: Purple.Engineering



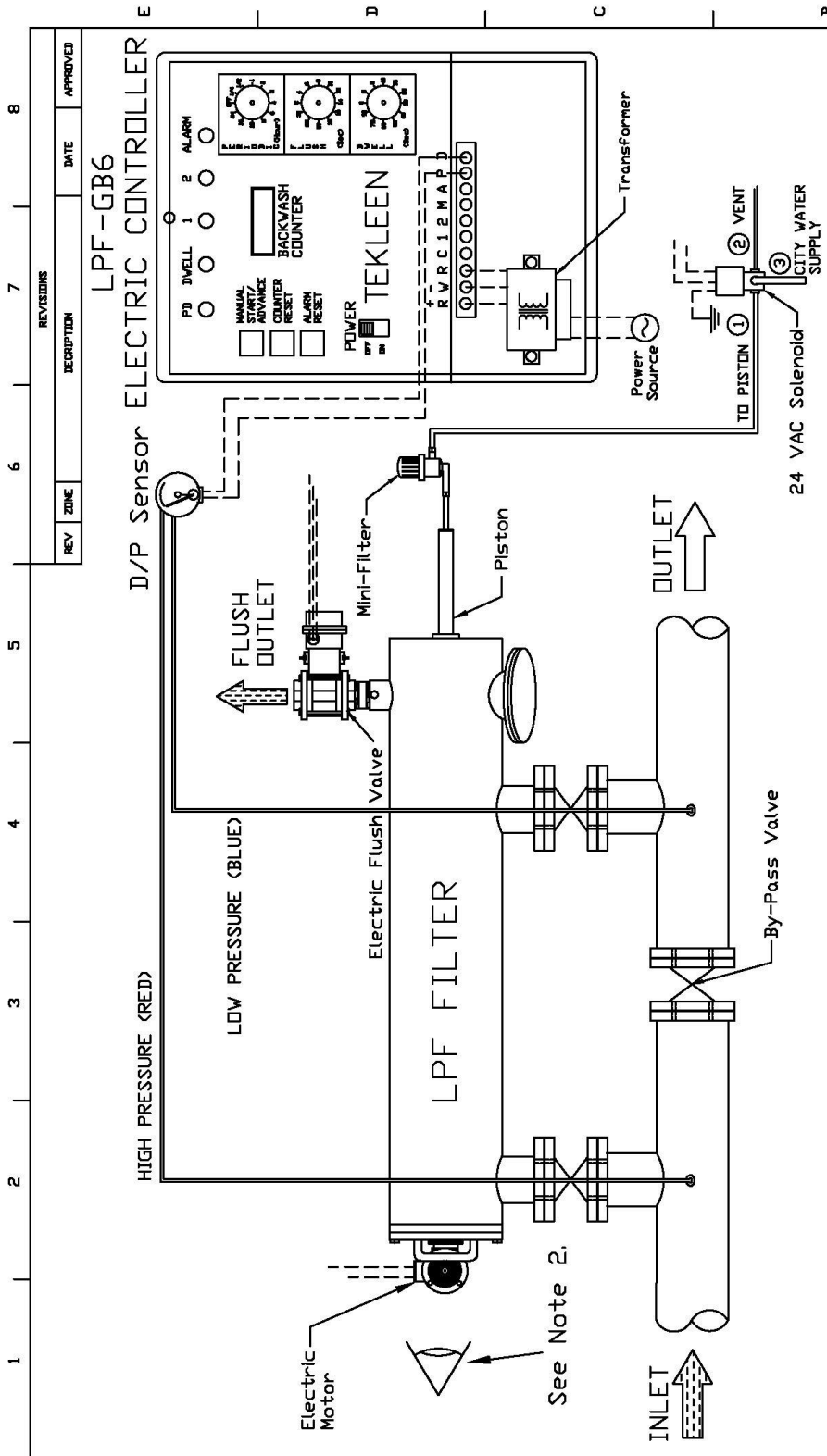

NOTES:

1. Electrical components are connected to a motor board, relays, circuit breaker, & transformer that are located inside electric controller box.
2. Motor must rotate counter clockwise from viewpoint for filters that contain a screen with area less than 5.0 sq. ft. (I.E. models LPF2-SP, 2-XLP, 3-LP, 3-SP, 4-LPE, 4-P & 6-P). Motor must rotate clockwise for all other filters.

Junction	○
No Junction	⌋
Wire	---
Hydraulic Tube	---

REV	ZONE	DESCRIPTION	DATE	APPROVED

LPF-GB6
ELECTRIC CONTROLLER

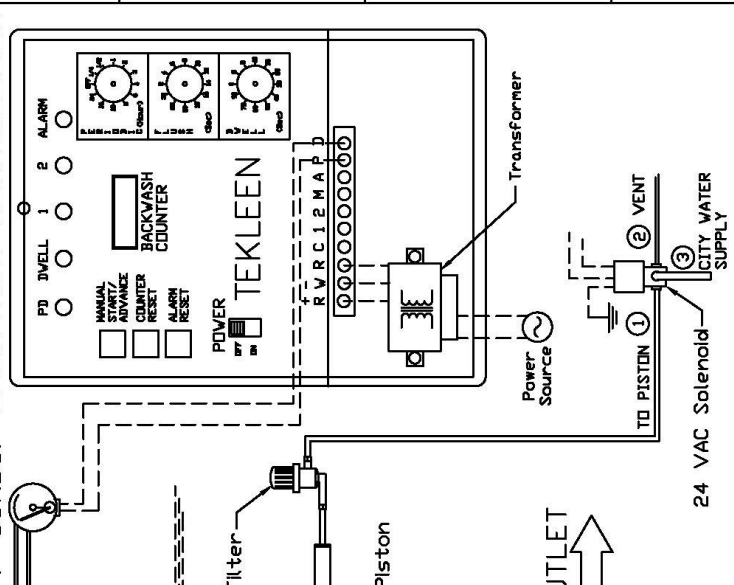

UNLESS OTHERWISE SPECIFIED DIMENSIONS ARE IN INCHES TOLERANCES		AUTOMATIC FILTERS, INC. 2672 S. LA CIENEGA BLVD. LOS ANGELES, CA 90034 (310) 839-2828 FAX (310) 839-6878	
DECIMALS .XXX ± .01	ANGULAR °.005 ± .01	TITLE LAYOUT FOR LPF FILTER WITH GB6 CONTROLLER, ELECTRIC FLUSH VALVE, & SOLENOID VENT FOR PISTON	
DRAWN S. PERKINSIN	DATE 04/20/13	SIZE A	REV N/A
CHECKED	DESIGN FOR	Not To Scale	SHEET 1 OF 1

For more information:

WEB: FLTR.com.au PHONE: (+61) 1300 62 4020 EMAIL: info@FLTR.com.au SKYPE: Purple.Engineering



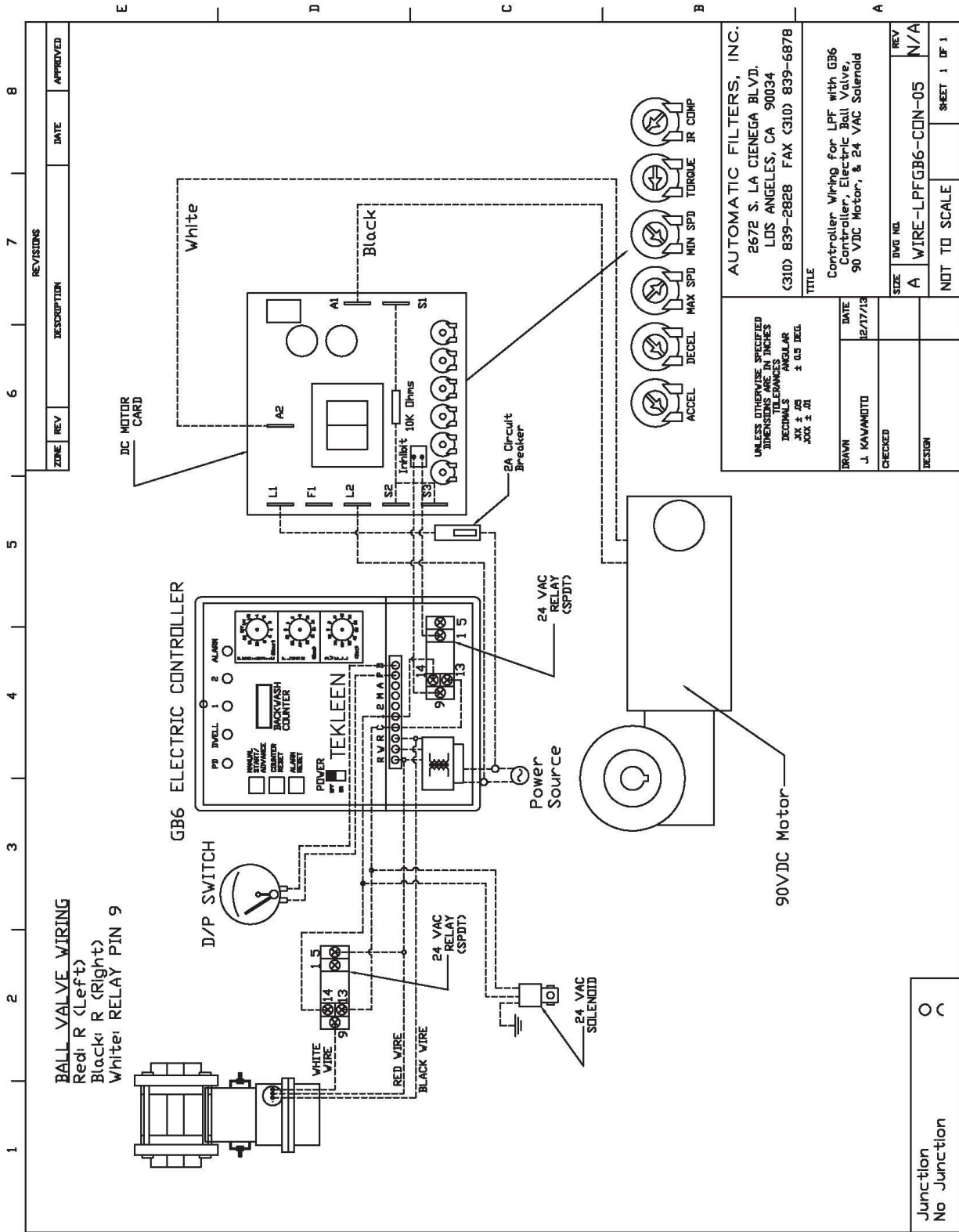

For more information:

WEB: FLTR.com.au PHONE: (+61) 1300 62 4020 EMAIL: info@FLTR.com.au SKYPE: Purple.Engineering

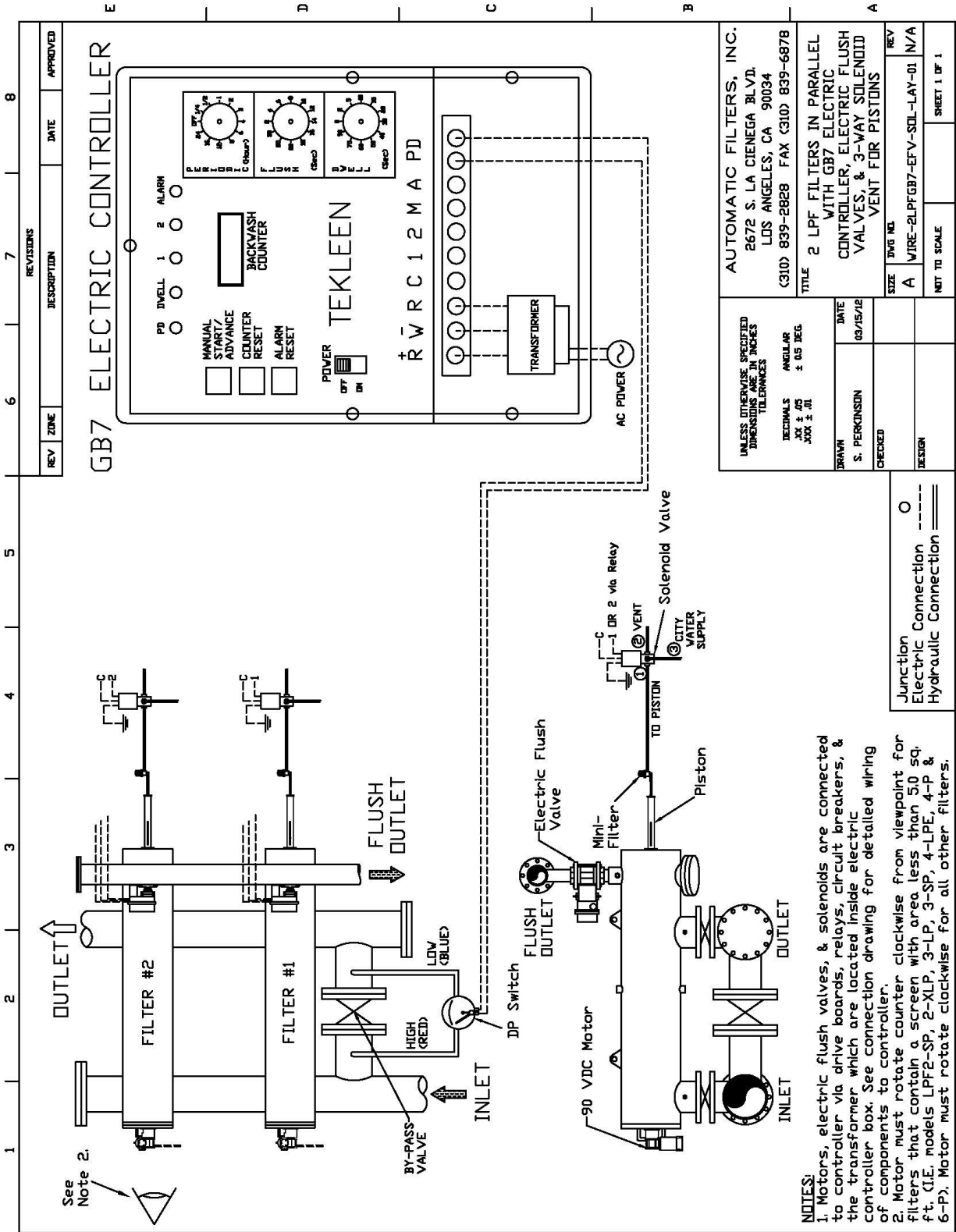

For more information:

WEB: FLTR.com.au PHONE: (+61) 1300 62 4020 EMAIL: info@FLTR.com.au SKYPE: Purple.Engineering



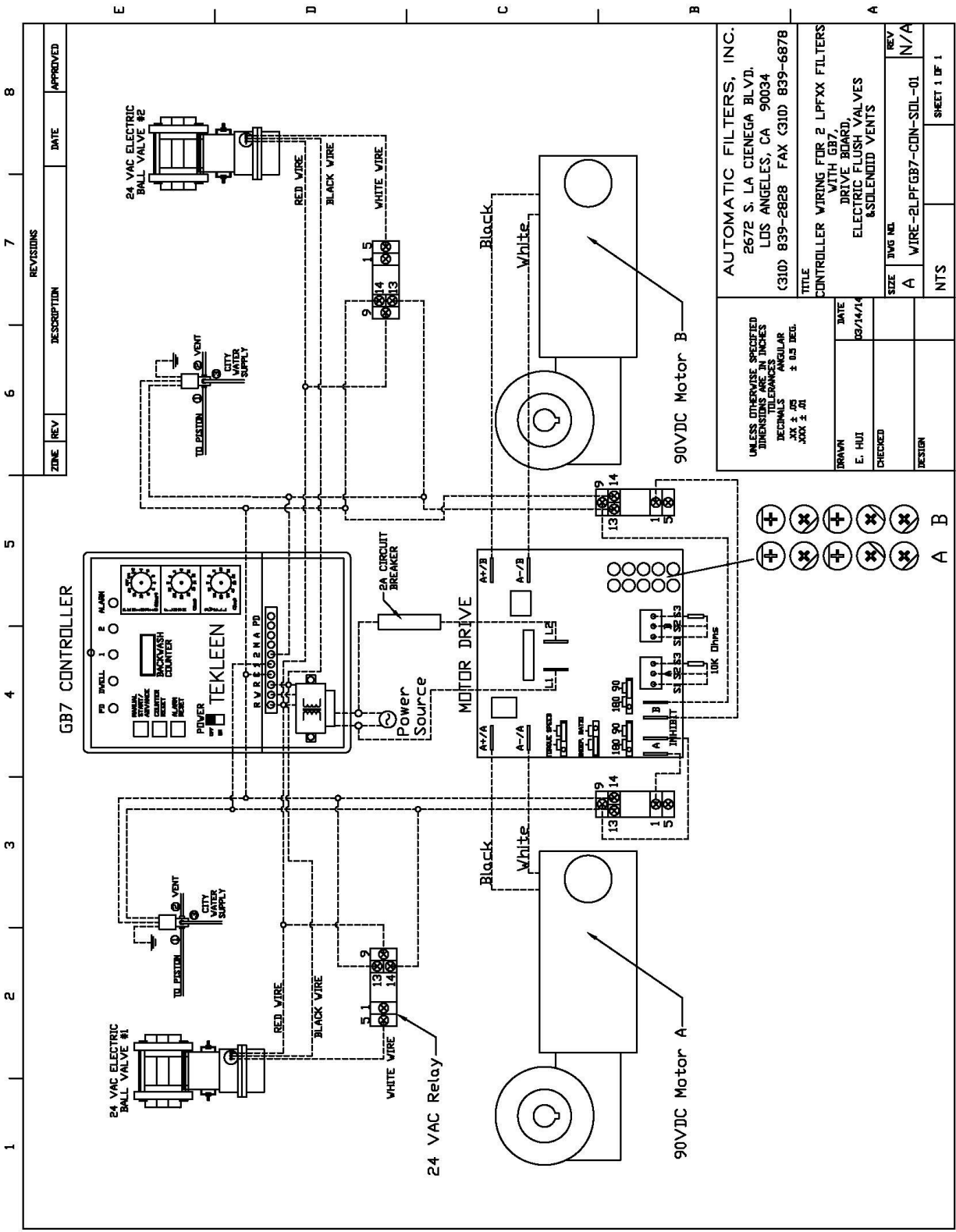

ZONE	REV	DESCRIPTION	DATE	APPROVED

UNLESS OTHERWISE SPECIFIED DIMENSIONS ARE IN INCHES DECIMALS ANGULAR .XX ± .05 .05 DEG. .XXX ± .01		AUTOMATIC FILTERS, INC. 2672 S. LA CIENEGA BLVD. LOS ANGELES, CA 90034 (310) 839-2828 FAX (310) 839-6878	
TITLE CONTROLLER WIRING FOR 2 LPFXX FILTERS WITH GB7, DRIVE BOARD, ELECTRIC FLUSH VALVES & SOLENOID VENTS			
DRAWN E. HUI	DATE 03/14/14	SIZE JWG ML	REV N/A
CHECKED		A	WIRE-2LPFG7-CON-SOL-01
DESIGN		NTS	SHEET 1 OF 1

For more information:

WEB: FLTR.com.au PHONE: (+61) 1300 62 4020 EMAIL: info@FLTR.com.au SKYPE: Purple.Engineering

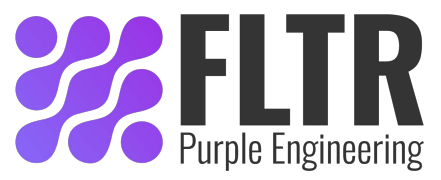

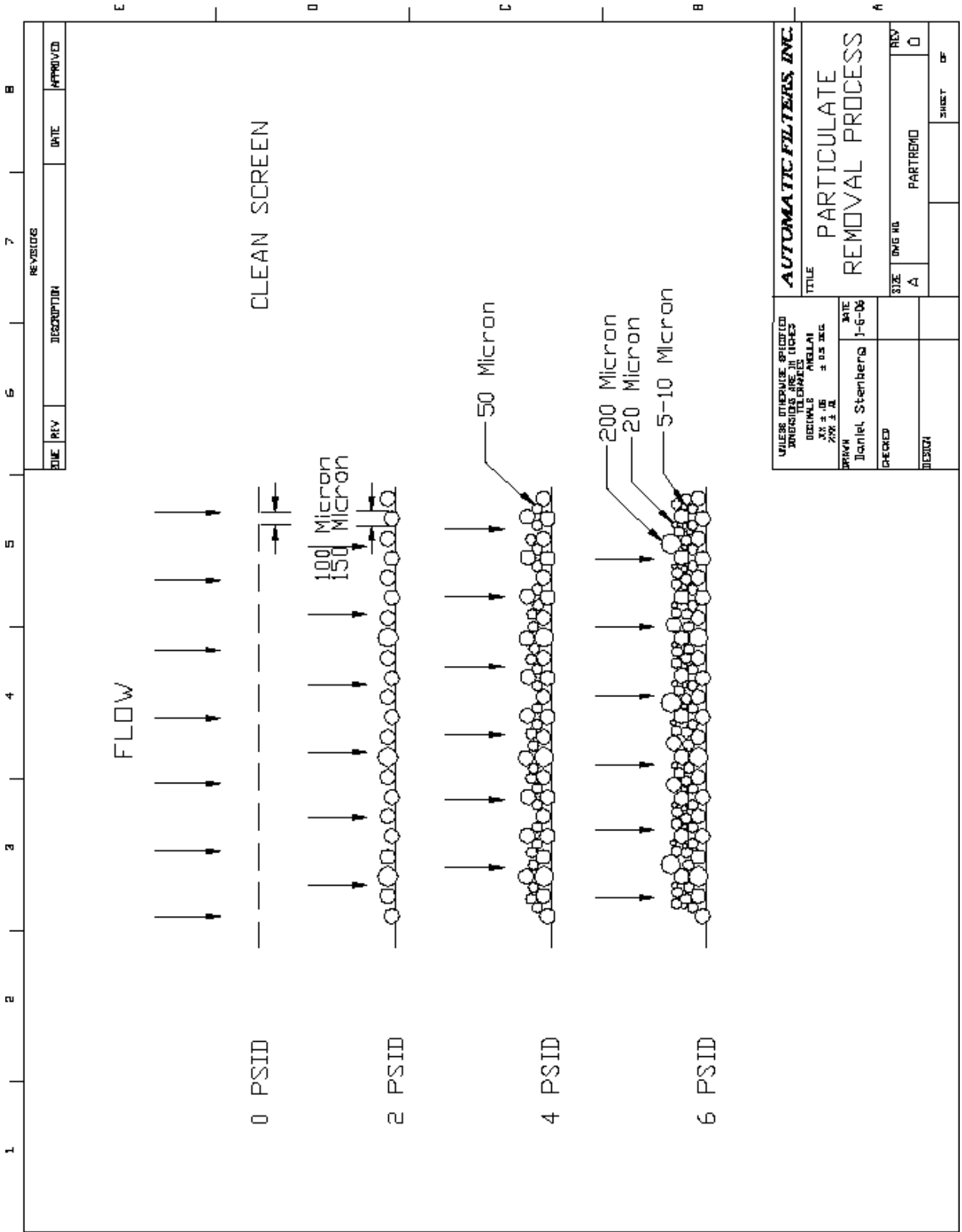

DATE	REV	DESCRIPTION	DATE	APPROVED

1 2 3 4 5 6 7 B

AUTOMATIC FILTERS, INC. TITLE PARTICULATE REMOVAL PROCESS		SIZE A	DWG NO PARTREMO	REV 0
DESIGNER Daniel Stenberg		DATE 1-6-06		SHEET 01
CHECKED		DESIGN		OF
USER: INTERVIEW SCHEDULED APPROVALS ARE IN EFFECT TELEPHONE		DECIMALS JAN 06 ± 0.5 DEG 200 ± 0.1		ANGLE ANGLES

For more information:

WEB: FLTR.com.au PHONE: (+61) 1300 62 4020 EMAIL: info@FLTR.com.au SKYPE: Purple.Engineering



PRESSURE DROP DATA 1SQ FT.

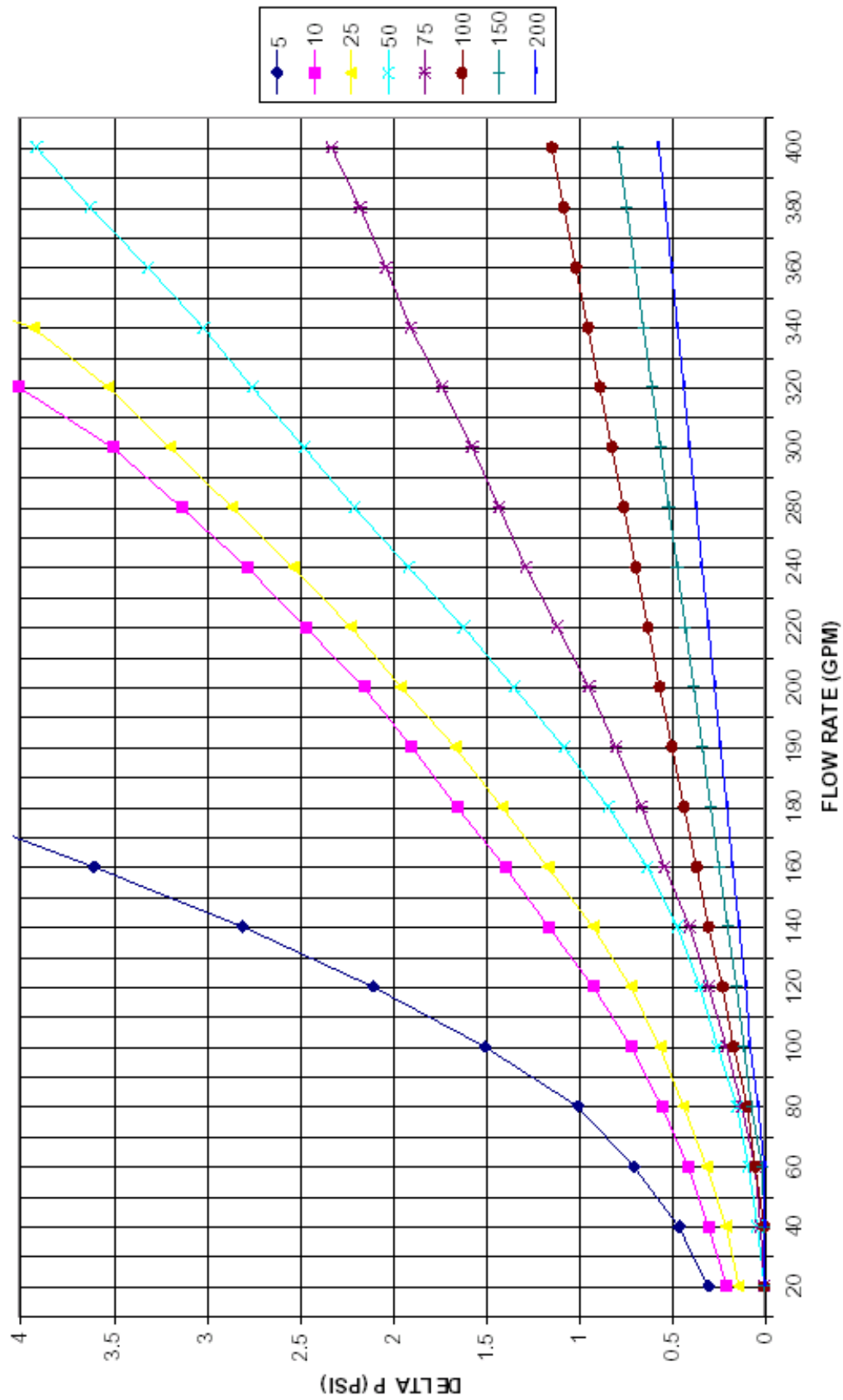

For more information:

WEB: FLTR.com.au PHONE: (+61) 1300 62 4020 EMAIL: info@FLTR.com.au SKYPE: Purple.Engineering



WARRANTY

Automatic Filters, Inc. (AFI) warrants its filters and controllers to be free from original defects for one year from the date of original sale. The manufacturer will replace, free of charge, any part found defective under normal use and service within the guarantee period, provided the product is installed, used, and maintained in accordance with good engineering practice and all applicable instructions or limitations issued by AFI. The manufacturer assumes no liability for incidental or consequential damage sustained in the adoption or use of our engineering data, service, or products. Liability is limited to the repair or replacement of the products. No agent or representative of AFI has the authority to waive or add to this agreement. Altered products or use of products in a manner not intended shall void this warranty. All warranty claims must be sent along with the defective product, freight prepaid to AFI at its business address. All warranty shipments are for the account of the buyer. The warranty period shall be 12 months from the date of shipment to the client.

For more information:

WEB: FLTR.com.au **PHONE:** (+61) 1300 62 4020 **EMAIL:** info@FLTR.com.au **SKYPE:** Purple.Engineering

