

REVISIONS				
REV.	ZONE	DESCRIPTION	DATE	INITIAL
1	7D	ADDED NOTE 1.	04/21/15	M.S.

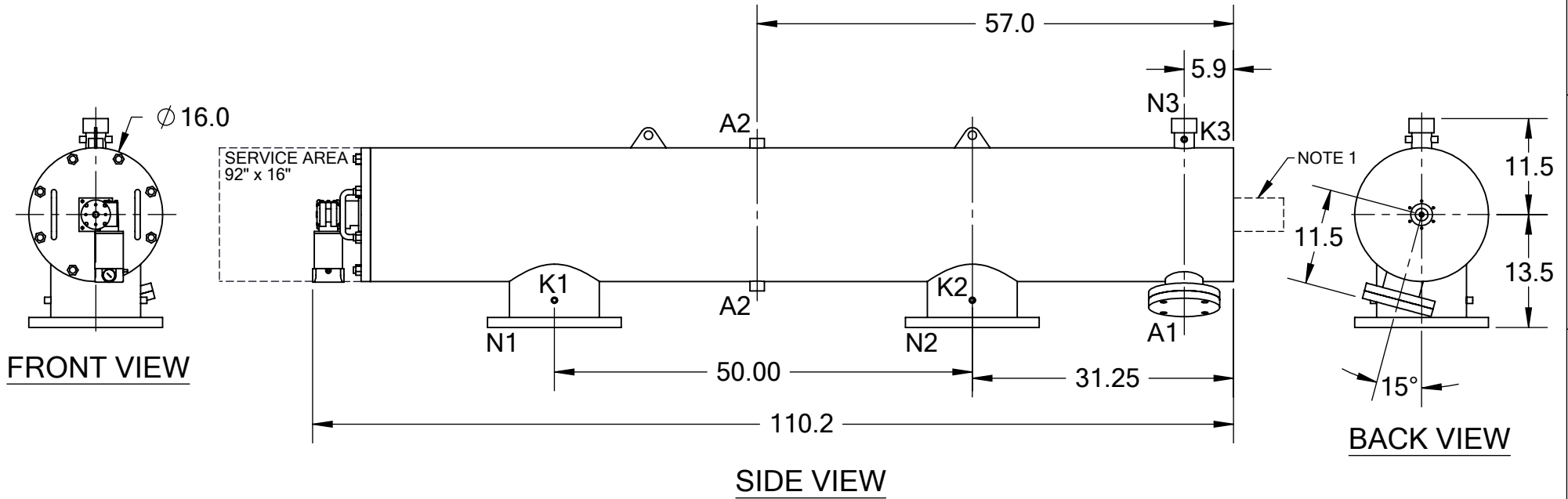

TECHNICAL DATA

FLOW RATE	MAX. 2,630 GPM (597 m ³ /hr)
SCREEN SIZE	___ MICRON
SCREEN AREA	11.0 SQ. FEET
DESIGN TEMPERATURE	160 °F
DESIGN PRESSURE	150 PSI
EMPTY WEIGHT	~650 LBS.
FULL WEIGHT	~1,400 LBS.

NOTES:

- PLEASE ALLOW ~20" ADDITIONAL TO INSTALL AND REMOVE THE PISTON ASSEMBLY TO THE BACKSIDE OF THE FILTER.

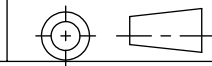
NOZZLE	CONNECTION	TYPE	SIZE	RATING	TOLERANCES (UNLESS OTHERWISE SPECIFIED)		
A1	SERVICE PORT	FLANGED	3.5" ASA	CL. #150 F.F. w/ Blind	FRAC. ±1/16	ANGLE ±1°	
A2	PRESSURE RELEASE	THREADED	1" NPT(2)		.X ±.1		
K1	HIGH PRESSURE CONN.	THREADED	1/4" NPT(2)	.XX ±.05	MATERIAL: SST		DRAWN BY: S. PERKINSON
K2	LOW PRESSURE CONN.	THREADED	1/4" NPT(2)	.XXX ±.010		DATE: 04/24/12	
K3	HYDRAULIC CONN.	THREADED	1/4" NPT(2)	CLASS #150 F.F.S.O. CLASS #150 F.F.S.O.	SHEET: 1 OF 1		REV 1
N1	INLET	FLANGED	10" ASA			SCALE: 1:18	
N2	OUTLET	FLANGED	10" ASA				
N3	FLUSH OUTLET	THREADED	2" NPT				