

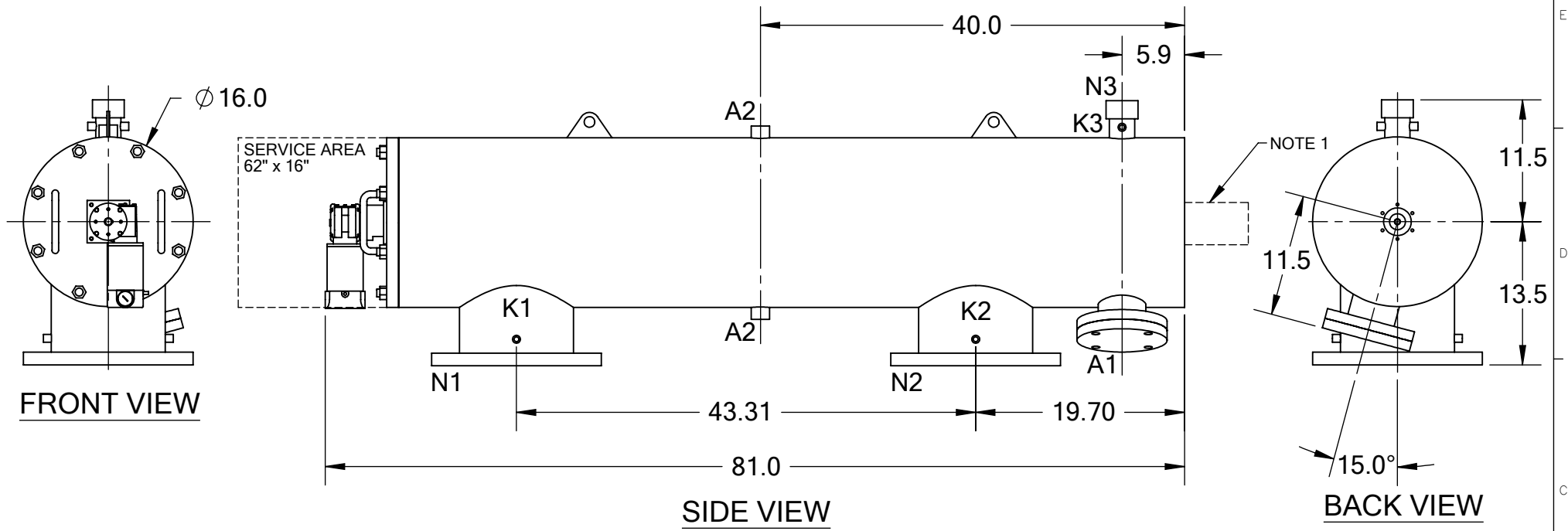

REVISIONS				
REV.	ZONE	DESCRIPTION	DATE	INITIAL
1	7D	ADDED NOTE 1.	04/28/15	M.S.



**TECHNICAL DATA**

FLOW RATE	MAX. 1,750 GPM (397 m <sup>3</sup> /hr)
SCREEN SIZE	___ MICRON
SCREEN AREA	7.0 SQ. FEET
DESIGN TEMPERATURE	160 °F
DESIGN PRESSURE	150 PSI
EMPTY WEIGHT	~585 LBS.
FULL WEIGHT	~1,110 LBS.

**NOTES:**  
 1. PLEASE ALLOW ~20" ADDITIONAL TO INSTALL AND REMOVE THE PISTON ASSEMBLY TO THE BACKSIDE OF THE FILTER.

NOZZLE	CONNECTION	TYPE	SIZE	RATING	TOLERANCES (UNLESS OTHERWISE SPECIFIED)		
A1	SERVICE PORT	FLANGED	3.5" ASA	CL. #150 F.F. w/ Blind	FRAC. ±1/16	ANGLE ±1°	
A2	PRESSURE RELEASE	THREADED	1" NPT(2)		.X ±.1		<b>MATERIAL:</b> SST <b>DRAWN BY:</b> S. PERKINSON <b>DATE:</b> 04/19/12 <b>SCALE:</b> 1:14
K1	HIGH PRESSURE CONN.	THREADED	1/4" NPT(2)	CLASS #150 F.F.S.O. CLASS #150 F.F.S.O.	.XX ±.05	<b>SHEET:</b> 1 OF 1	
K2	LOW PRESSURE CONN.	THREADED	1/4" NPT(2)		.XXX ±.010		<b>REV</b> 1
K3	HYDRAULIC CONN.	THREADED	1/4" NPT(2)				
N1	INLET	FLANGED	10" ASA				
N2	OUTLET	FLANGED	10" ASA				
N3	FLUSH OUTLET	THREADED	2" NPT				