

REVISIONS				
REV.	ZONE	DESCRIPTION	DATE	INITIAL

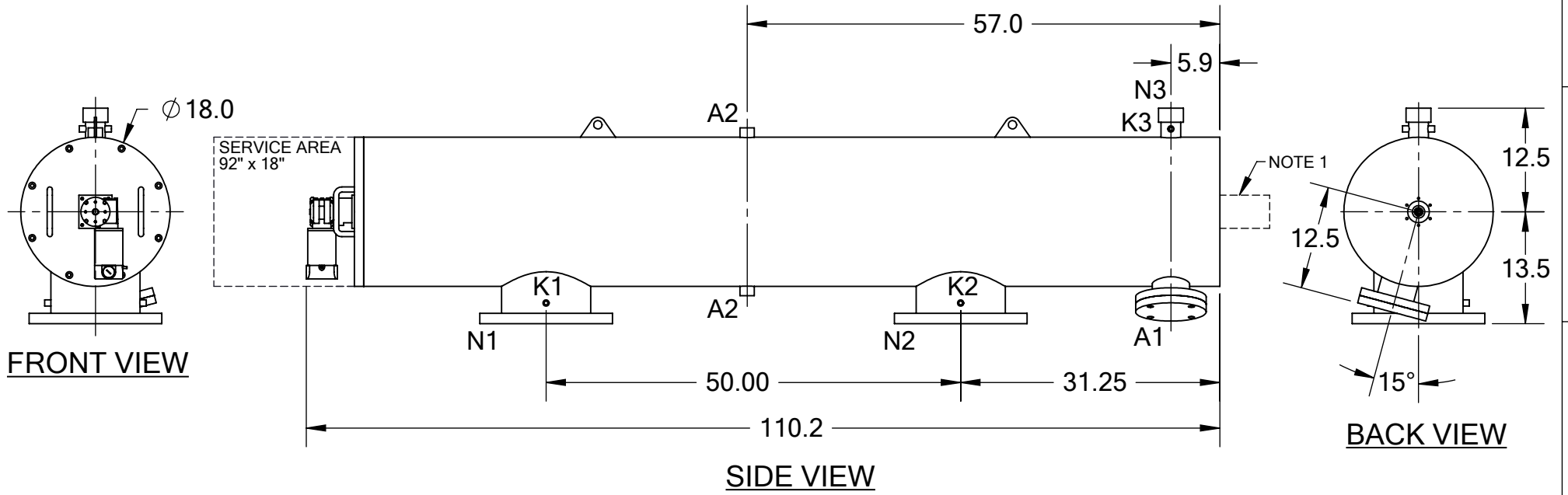

TECHNICAL DATA

FLOW RATE	MAX. 4,000 GPM (908 m ³ /hr)
SCREEN SIZE	___ MICRON
SCREEN AREA	12.5 SQ. FEET
DESIGN TEMPERATURE	160 °F
DESIGN PRESSURE	150 PSI
EMPTY WEIGHT	~825 LBS.
FULL WEIGHT	~1,275 LBS.

NOTES:

- PLEASE ALLOW ~20" ADDITIONAL TO INSTALL AND REMOVE THE PISTON ASSEMBLY TO THE BACKSIDE OF THE FILTER.

NOZZLE	CONNECTION	TYPE	SIZE	RATING
A1	SERVICE PORT	FLANGED	3.5" ASA	CL. #150 F.F. w/ Blind
A2	PRESSURE RELEASE	THREADED	1" NPT(2)	
K1	HIGH PRESSURE CONN.	THREADED	1/4" NPT(2)	
K2	LOW PRESSURE CONN.	THREADED	1/4" NPT(2)	CLASS #150 F.F.S.O.
K3	HYDRAULIC CONN.	THREADED	1/4" NPT(2)	
N1	INLET	FLANGED	10" ASA	
N2	OUTLET	FLANGED	10" ASA	CLASS #150 F.F.S.O.
N3	FLUSH OUTLET	THREADED	2" NPT	

TOLERANCES (UNLESS OTHERWISE SPECIFIED)	
FRAC. ±1/16	ANGLE ±1°
.X ±.1	
.XX ±.05	
.XXX ±.010	
MATERIAL: SST	
DRAWN BY: M. SERRANO	
DATE: 11/15/18	
SCALE: 1:18	SHEET: 1 OF 1



TITLE: LPF10-SLP FILTER CUT DRAWING	
DRAWING NUMBER LPF-10SLP-CUT-01	REV N/A