

REVISIONS				
REV.	ZONE	DESCRIPTION	DATE	INITIAL

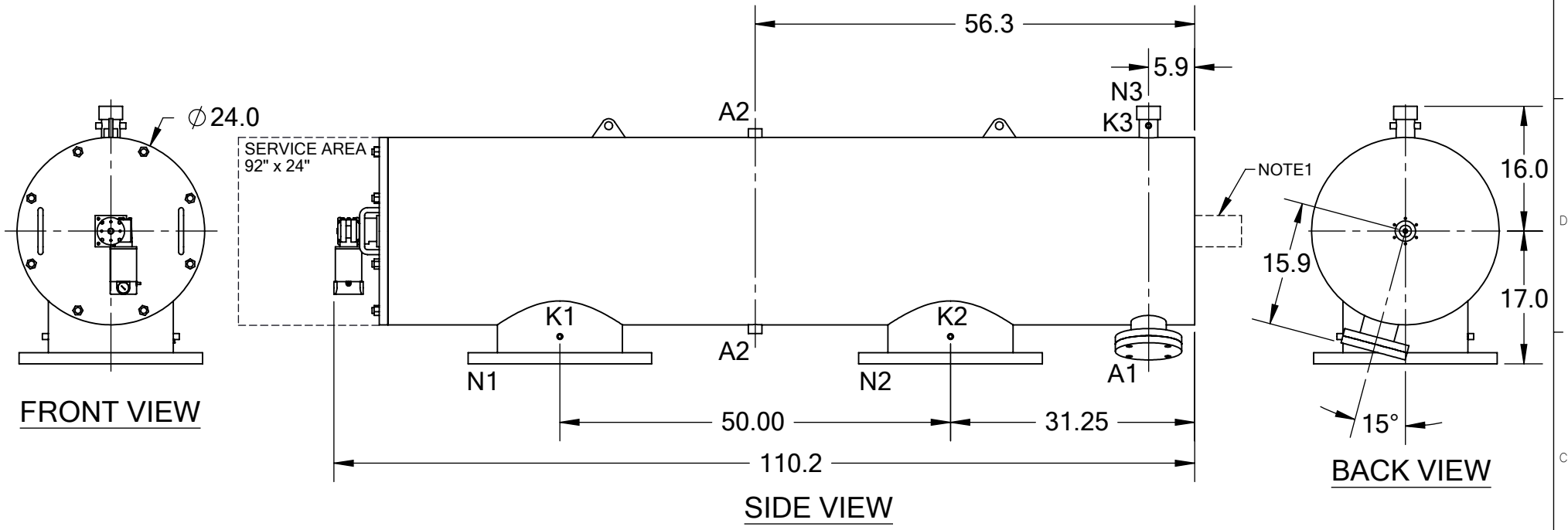

TECHNICAL DATA

FLOW RATE	MAX. 6,000 GPM (1,363 m ³ /hr)
SCREEN SIZE	___ MICRON
SCREEN AREA	16.0 SQ. FEET
DESIGN TEMPERATURE	160 °F
DESIGN PRESSURE	150 PSI
EMPTY WEIGHT	~1,450 LBS.
FULL WEIGHT	~2,150 LBS.

NOTES:

- PLEASE ALLOW ~20" ADDITIONAL TO INSTALL AND REMOVE THE PISTON ASSEMBLY TO THE BACKSIDE OF THE FILTER.

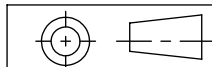
NOZZLE	CONNECTION	TYPE	SIZE	RATING	TOLERANCES (UNLESS OTHERWISE SPECIFIED)	
A1	SERVICE PORT	FLANGED	3.5" ASA	CL. #150 F.F. w/ Blind		
A2	PRESSURE RELEASE	THREADED	1" NPT(2)		ANGLE ±1° 	TITLE: LPF18-LP FILTER, CUT DRAWING
K1	HIGH PRESSURE CONN.	THREADED	1/4" NPT(2)		MATERIAL: SST	
K2	LOW PRESSURE CONN.	THREADED	1/4" NPT(2)		DRAWN BY: S. PERKINSON	DRAWING NUMBER REV LPF-18LP-CUT-01 N/A
K3	HYDRAULIC CONN.	THREADED	1/4" NPT(2)		DATE: 05/05/2015	
N1	INLET	FLANGED	18" ASA	CLASS #150 F.F.S.O.	SCALE: 1:19	
N2	OUTLET	FLANGED	18" ASA	CLASS #150 F.F.S.O.	SHEET: 1 OF 1	
N3	FLUSH OUTLET	THREADED	2" NPT			