

REVISIONS				
ZONE	REV	DESCRIPTION	DATE	APPROVED

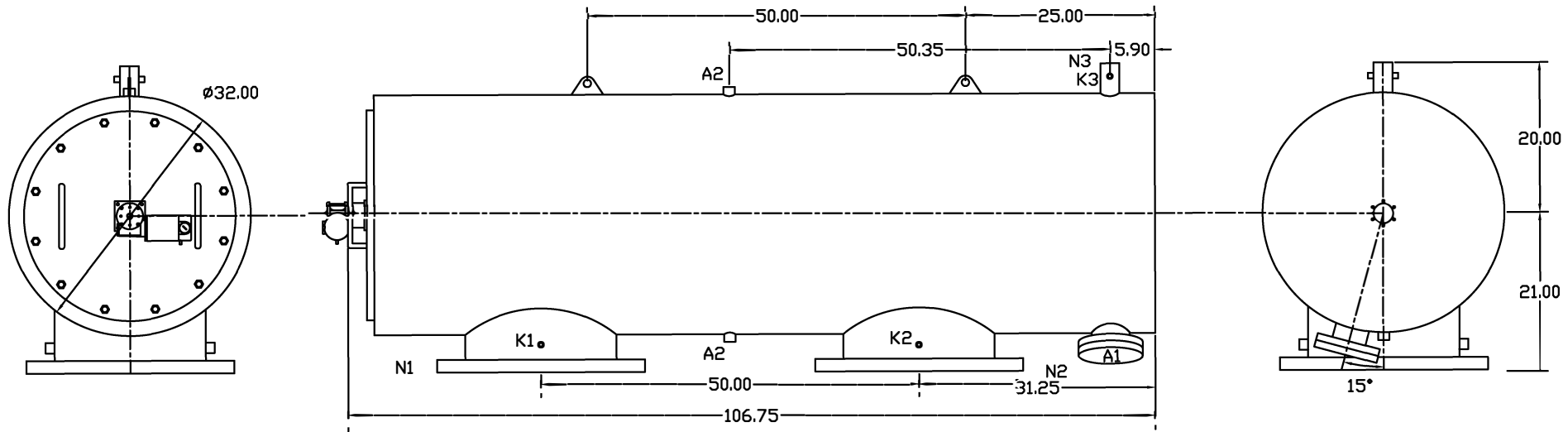

TECHNICAL DATA

Flow Rate	Max.10,000 GPM
Screen Size	--- Micron
Screen Area	24.0 sq.ft.
Working Temp.	200 deg. F
Working Pressure	150 PSI
Empty Weight	2500 lbs.
Full Weight	---- lbs.

NOZZLE	CONNECTION	TYPE OF CONNECTION	SIZE	RATING
A1	Service Port	Flanged	4" ASA	150 lbs. F.F. w/Blind
A2	Service Port	Threaded	1" NPT(2)	
K1	Hl. Press. Conn.	Threaded	1/4" NPT (2)	
K2	Low Press. Conn.	Threaded	1/4" NPT (2)	
K3	Flushoutlet Conn.	Threaded	1/4" NPT(2)	
N1	Inlet	Flanged	24" ASA	150 lbs. F.F.
N2	Outlet	Flanged	24" ASA	150 lbs. F.F.
N3	Flushoutlet	Threaded	2" NPT	

UNLESS OTHERWISE SPECIFIED
DIMENSIONS ARE IN INCHES
TOLERANCES
DECIMALS ANGULAR
.XX ± .05 ± 0.5 DEG.
.XXX ± .01



DRAWN	DATE
Daniel Stenberg	5-8-09
CHECKED	
DESIGN	

TITLE		
LPF24-SP		
SIZE	DWG. NO.	REV
A	LPF24-SP-2	0
NOT TO SCALE		SHEET OF