

REVISIONS				
REV.	ZONE	DESCRIPTION	DATE	INITIAL
1	7D	ADDED NOTE 1.	04/16/15	M.S.

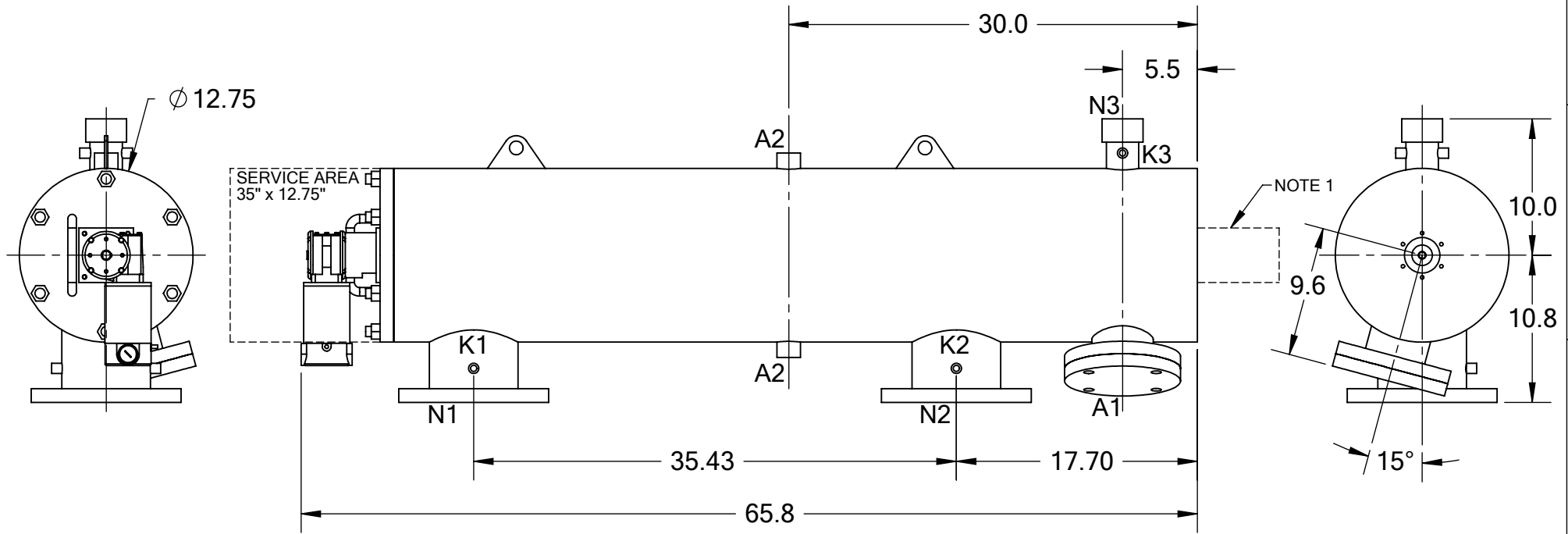

TECHNICAL DATA

FLOW RATE	MAX. 800 GPM (182 m ³ /hr)
SCREEN SIZE	___ MICRON
SCREEN AREA	5.0 SQ. FEET
DESIGN TEMPERATURE	160 °F
DESIGN PRESSURE	150 PSI
EMPTY WEIGHT	~300 LBS.
FULL WEIGHT	~650 LBS.

NOTES:

- PLEASE ALLOW ~20" ADDITIONAL TO INSTALL AND REMOVE THE PISTON ASSEMBLY TO THE BACKSIDE OF THE FILTER.

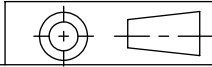
NOZZLE	CONNECTION	TYPE	SIZE	RATING	TOLERANCES (UNLESS OTHERWISE SPECIFIED)	
A1	SERVICE PORT	FLANGED	3.5" ASA	CL. #150 F.F. w/ Blind		
A2	PRESSURE RELEASE	THREADED	1" NPT(2)		ANGLE ±1°	
K1	HIGH PRESSURE CONN.	THREADED	1/4" NPT(2)			
K2	LOW PRESSURE CONN.	THREADED	1/4" NPT(2)			TITLE: LPF6-LP FILTER, CUT DRAWING
K3	HYDRAULIC CONN.	THREADED	1/4" NPT(2)			
N1	INLET	FLANGED	6" ASA	CLASS #150 F.F.S.O.	MATERIAL: SST	DRAWING NUMBER LPF-6LP-CUT-01
N2	OUTLET	FLANGED	6" ASA	CLASS #150 F.F.S.O.	DRAWN BY: S. PERKINSON	
N3	FLUSH OUTLET	THREADED	2" NPT		DATE: 04/11/12	REV 1
					SCALE: 1:11	