

REVISIONS				
REV.	ZONE	DESCRIPTION	DATE	INITIAL
1	7D	ADDED NOTE 1.	04/16/15	M.S.

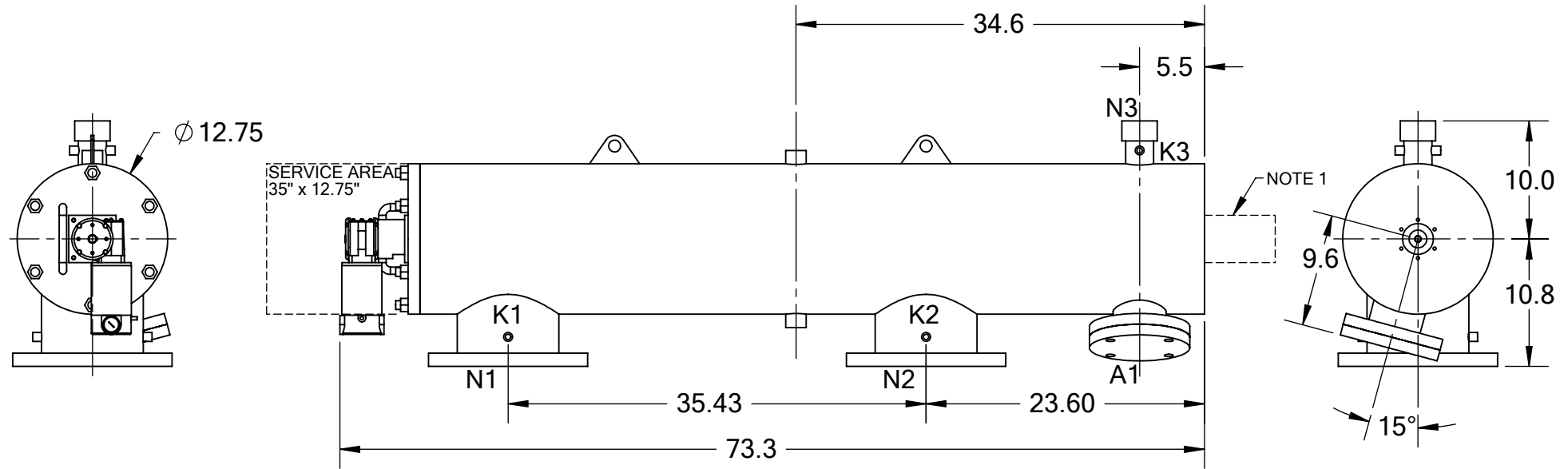

TECHNICAL DATA

FLOW RATE	MAX. 1,320 GPM (300 m <sup>3</sup> /hr)
SCREEN SIZE	___ MICRON
SCREEN AREA	5.0 SQ. FEET
DESIGN TEMPERATURE	160 °F
DESIGN PRESSURE	150 PSI
EMPTY WEIGHT	~340 LBS.
FULL WEIGHT	~800 LBS.

NOTES:

- PLEASE ALLOW ~20" ADDITIONAL TO INSTALL AND REMOVE THE PISTON ASSEMBLY TO THE BACKSIDE OF THE FILTER.

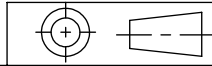
NOZZLE	CONNECTION	TYPE	SIZE	RATING	TOLERANCES (UNLESS OTHERWISE SPECIFIED)		
A1	SERVICE PORT	FLANGED	3.5" ASA	CL. #150 F.F. w/ Blind  CLASS #150 F.F.S.O. CLASS #150 F.F.S.O.	FRAC. ±1/16	ANGLE ±1°	
A2	PRESSURE RELEASE	THREADED	1" NPT(2)		.X ±.1		
K1	HIGH PRESSURE CONN.	THREADED	1/4" NPT(2)		.XX ±.05		
K2	LOW PRESSURE CONN.	THREADED	1/4" NPT(2)		.XXX ±.010		
K3	HYDRAULIC CONN.	THREADED	1/4" NPT(2)				
N1	INLET	FLANGED	8" ASA		<b>MATERIAL:</b> SST		
N2	OUTLET	FLANGED	8" ASA		<b>DRAWN BY:</b> S. PERKINSON		
N3	FLUSH OUTLET	THREADED	2" NPT		<b>DATE:</b> 04/11/12		
					<b>SCALE:</b> 1:13	<b>SHEET:</b> 1 OF 1	