

FRONT VIEW

REVISIONS				
REV.	ZONE	DESCRIPTION	DATE	INITIAL

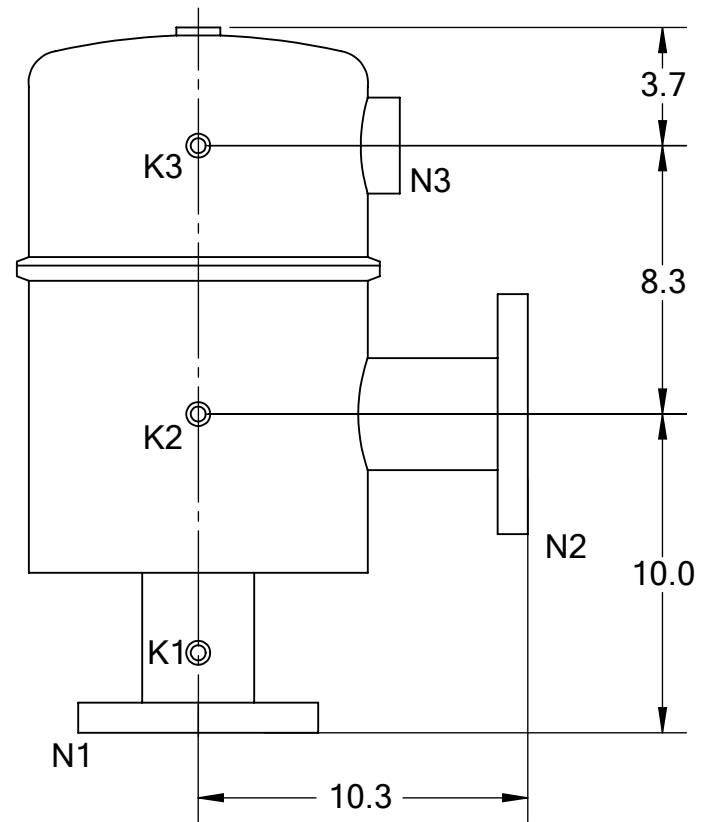

SIDE VIEW

TECHNICAL DATA

FLOW RATE	MAX. 350 GPM (80 m ³ /hr)
SCREEN SIZE	___ MICRON
SCREEN AREA	1.5 SQ. FEET
MAXIMUM TEMPERATURE	MAX. 200 °F
MAXIMUM PRESSURE	MAX. 150 PSI
EMPTY WEIGHT	~90 LBS.
FULL WEIGHT	~165 LBS.

NOZZLE	CONNECTION	TYPE	SIZE	RATING
K1	HIGH PRESSURE CONN.	THREADED	1/4" NPT(2)	CLASS #150 F.F.S.O.
K2	LOW PRESSURE CONN.	THREADED	1/4" NPT	
K3	HYDRAULIC CONN.	THREADED	1/4" NPT	CLASS #150 F.F.S.O.
N1	INLET	FLANGED	3" ASA	
N2	OUTLET	FLANGED	3" ASA	
N3	FLUSH OUTLET	THREADED	2" NPT	

TOLERANCES (UNLESS OTHERWISE SPECIFIED)

FRAC. ±1/16	ANGLE ±1°
.X ±.1	
.XX ±.05	
.XXX ±.010	



MATERIAL: SST
DRAWN BY: S. PERKINSON
DATE: 11/14/11
SCALE: 1:6

TITLE: MTF3 FILTER, CUT DRAWING	
DRAWING NUMBER	REV
MTF-3-CUT-01	N/A