

FRONT VIEW

REVISIONS				
REV.	ZONE	DESCRIPTION	DATE	INITIAL
1	2C	CHANGED INLET LENGTH FROM 5.0" TO 7.0", ADDED 2ND LIFTING LUG.	08/13/12	S.P.

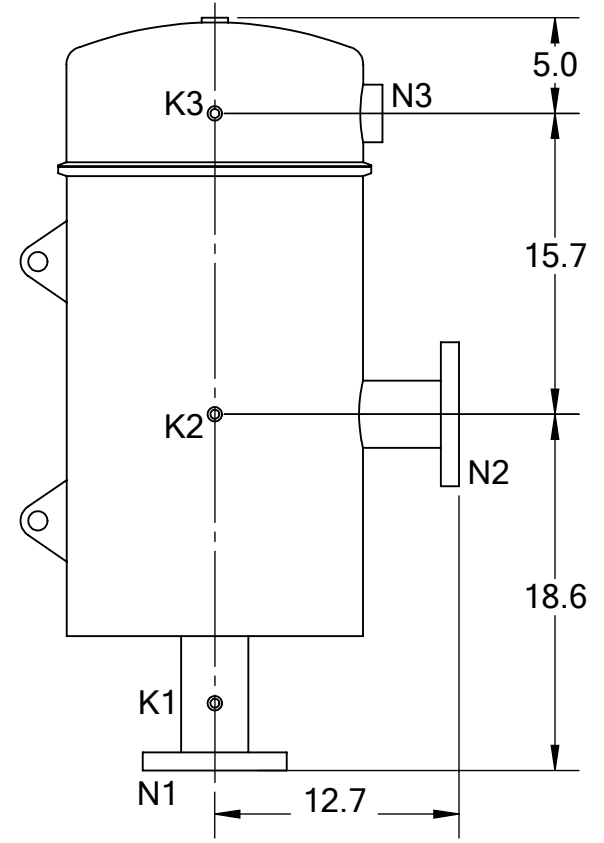

SIDE VIEW

TECHNICAL DATA

FLOW RATE	MAX. 500 GPM (114 m ³ /hr)
SCREEN SIZE	___ MICRON
SCREEN AREA	5.0 SQ. FEET
DESIGN TEMPERATURE	160 °F
DESIGN PRESSURE	150 PSI
EMPTY WEIGHT	~175 LBS.
FULL WEIGHT	~425 LBS.

NOZZLE	CONNECTION	TYPE	SIZE	RATING
K1	HIGH PRESSURE CONN.	THREADED	1/4" NPT(2)	
K2	LOW PRESSURE CONN.	THREADED	1/4" NPT	
K3	HYDRAULIC CONN.	THREADED	1/4" NPT	
N1	INLET	FLANGED	3" ASA	CLASS #150 F.F.S.O.
N2	OUTLET	FLANGED	3" ASA	CLASS #150 F.F.S.O.
N3	FLUSH OUTLET	THREADED	2" NPT	

TOLERANCES (UNLESS OTHERWISE SPECIFIED)	
FRAC. ±1/16	ANGLE ±1°
.X ±.1	
.XX ±.05	
.XXX ±.010	
MATERIAL: SST	
DRAWN BY: S. PERKINSON	
DATE: 11/11/11	
SCALE: 1:10	SHEET: 1 OF 1

TITLE:
MTF3-XL FILTER,
CUT DRAWING

DRAWING NUMBER **REV**
MTF-3XL-CUT-01 1