

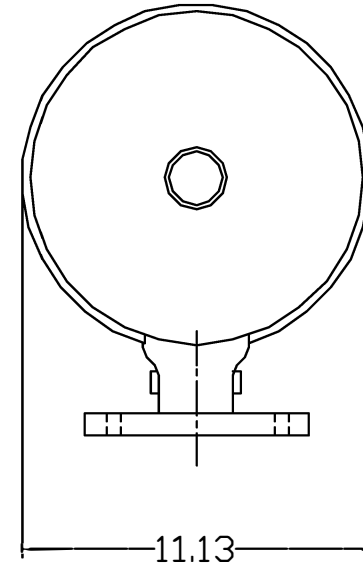

REVISIONS				
ZONE	REV	DESCRIPTION	DATE	APPROVED

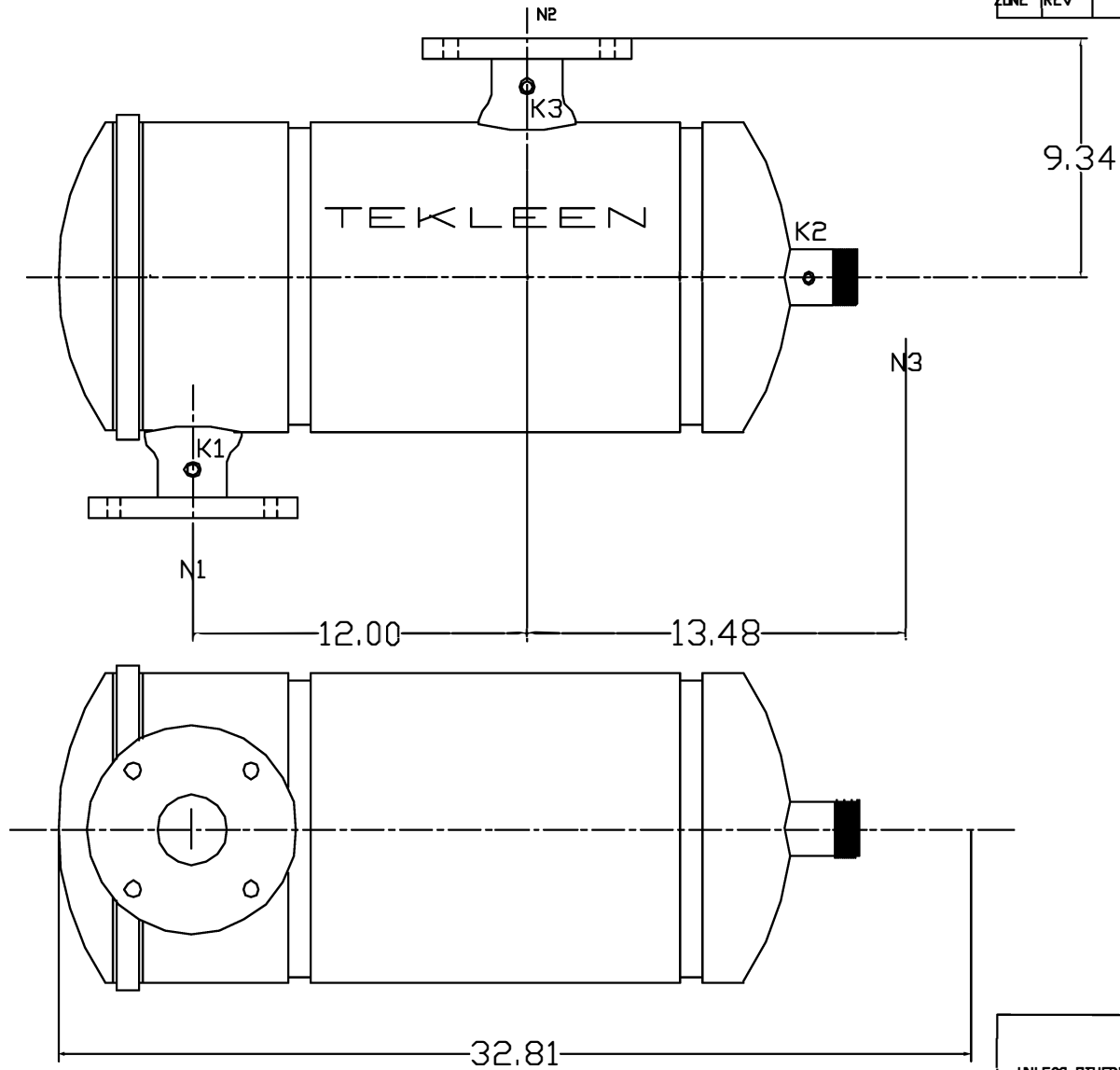

NOZZLE	CONNECTION	TYPE	SIZE
N1	INLET	FLANGED	3" ASA
N2	OUTLET	FLANGED	3" ASA
N3	FLUSH OUTLET	THREADED	2" NPT
K1	Hi Pres. Conn.	THREADED	1/4" NPT
K2	BackWash P.	THREADED	1/4" NPT
K3	Low Pres.	THREADED	1/4" NPT

FLOW RATE: MAX. 250 GPM
 MAX. PRESS: 125 PSI
 SCREEN SIZE: 5-400 MICRON
 SCREEN AREA: 1.5 SQ.FT.
 MAX. TEMP: 140 F (AVAIL. TO 210 F)
 WEIGHT: 75 LBS.

UNLESS OTHERWISE SPECIFIED DIMENSIONS ARE IN INCHES TOLERANCES DECIMALS ANGULAR XX ± .05 ± 0.5 DEG XXX ± .01			
DRAWN Daniel Stenberg		DATE 2-21-07	
CHECKED		TITLE OBF3-I	
DESIGN		SIZE A	DWG NO. OBF3-I
		SCALE 1/6	REV 0
		SHEET 1 OF 1	