

OBF *USERS'* MANUAL



Table of Contents

SECTION I INTRODUCTION

1.1	Description	1
1.2	Theory of Operation	1
1.3	Recommended Applications	1
1.4	Design Features	2
1.5	Filter Specifications Chart	2
1.6	Measurement Conversion Table	2

SECTION II INSTALLATION AND HOOK-UP

2.1	Mechanical Hook-Up and Orientation	3
2.2	Plumbing Hook-Up	4
2.3	Electronic Controller Hook-Up	4

SECTION III OPERATION AND ADJUSTMENTS

3.1	Start-up	5
3.2	Pressure Differential Adjustment	6

SECTION VI MAINTENANCE

4.1	Filter Cleaning	6
4.2	Filter Replacement	7

SECTION V TROUBLESHOOTING GUIDE

5.1	Flushing Valve Does Not Close During Start-Up	7
5.2	Excessive Pressure Drop Through Filter Without Flushing	8
5.3	Flushing Valve Chatter	8
5.4	One Flushing Valve Stays Open (in multiple tank installations)	8
5.5	Frequent or Continuous Flushing while Filling Main Pipeline	9
5.6	Frequent Flushing During Normal Operation	9
5.7	When Changing Irrigation Blocks, Filter Flushes Rapidly	10
5.8	Screen Will Not Clean Properly	11

SECTION VI ILLUSTRATIONS

Filter Assembly	12
Filter Assembly (Exploded View)	13
Hydraulic Controller Connections	14
Electronic Controller Connections	15
Filtering and Flushing Sequence	16
2" OBF Filter	17
4" OBF Filter	18
Cutaway of an OBF Filter	19
OBF - 2 with GB6 Controller	20
Particulate Removal Process	21
Pressure Drop Chart	22

For more information:

WEB: FLTR.com.au **PHONE:** (+61) 1300 62 4020 **EMAIL:** info@FLTR.com.au **SKYPE:** Purple.Engineering

SECTION I INTRODUCTION

1.1 Description

The OBF series features automatic, self-cleaning screen type water filters. The filtration system consists of a tank body with a first stage mesh screen and a second stage fine screen, a 2" flushing valve and an electronic controller. (See OBF Design Specifications, pages 23 and 24)

1.2 Theory of Operation (see Page 16)

Pressurized water enters the filter inlet and travels through a 1/8" perforated stainless steel coarse screen where large particles are pre-filtered. The water then passes through a fine stainless steel screen where small contaminants (down to 10 microns) are filtered out. The clean water then exits the outlet.

When the fine screen becomes contaminated, a pressure differential is sensed causing the automatic controller to open the flushing valve. When the flushing valve opens, the pressure is reduced causing the clean water to reverse flow through the filter element pushing contaminants off the screen, through the nozzles, through the water motor and out the flush valve.

The water passing through the angular holes in the motor creates a torsional rotation of the nozzles, thus vacuuming the entire I.D. of the filter element.

When the screen is clean, the unit automatically returns to the full filtering mode.

The entire cleaning cycle takes approximately four to six seconds and uses 10 to 12 gallons of water. It should be noted that even during the backflush cycle, the filtration process continues uninterrupted.

1.3 Recommended Applications

Tekleen OBF water filters are ideal for filtering out silt, scale, sand, rust, dirt and organic material like algae, zebra muscles, and clams from virtually all types of water sources.

1.4 Design Features

Among the many features of the OBF models is their avoidance of the danger of forcing contaminated water back into the system, which often happens with a sand media filter. These filters will deliver clean water or no water.

The most predominant feature is its ability to remove organics such as algae and other suspended particles.

The entire back flushing mechanism and fine screen assembly is modular and can be removed from the filter body without disruption of the plumbing.

1.5 Filter Specifications Chart

Model #	Connection inches	Screen Area sq. ft.	Flushing Valve	Max Flow gpm	Empty Wt. lbs.
OBF - 2	2"	0.8	1	120	50
OBF - 3P	3"	1.5	2	250	60
OBF - 4P	4"	3.0	2	500	80

Specification: All stainless steel body with engineered plastic internals (determine). Maximum 125 psi, 200° F, triple layered stainless steel screen mesh 10 μ to 800 μ . 2 gallons per rinse with a 1" flushing valve & 8 gallons per rinse with a 2" valve.

1.6 Measurement Conversion Table

Mesh	20	40	60	80	100	140	200	325	550
Micron	850	590	250	177	150	105	74	44	25
Inch	.033	.016	.010	.007	.006	.004	.003	.002	.001

For more information:

WEB: FLTR.com.au PHONE: (+61) 1300 62 4020 EMAIL: info@FLTR.com.au SKYPE: Purple.Engineering

SECTION II INSTALLATION AND HOOK-UP

2.1 Mechanical Hook-Up and Orientation

The positioning of the filter tank should be determined by the disposal of waste water, and it should allow easy access and removal of filter element. (A minimum of three feet of clearance to the rear is required for OBF3-P and a minimum of four feet of clearance to the rear is required for OBF4-P)

The location of the flushing valve should provide for maximum unobstructed air discharge from the valve bonnet; this eliminates valve chatter during closing. The tank can rest on the inlet/outlet nipples or can be mounted on a stand if desired.

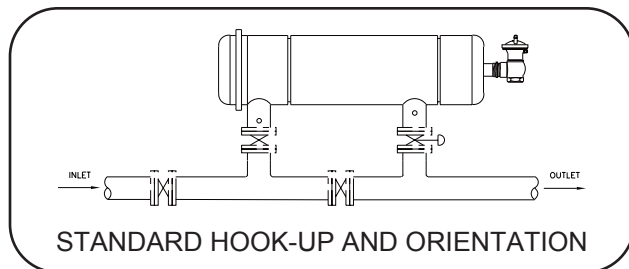

If two or more filters are required, it is recommended that they be manifolded with stainless steel manifolds above ground or PVC below ground and connected with 3" diameter risers extending above ground.

Assuming the filters are installed on a horizontal plane, the flushing valve is to be installed on the 2" diameter backflush nipple with the arrow pointing downstream and the bonnet pointing skyward.

When using the electronic controller model, mount solenoid on flushing valve and mount electronic controller in close proximity to the solenoid valve. The solenoid should be mounted in a vertical and upright position to reduce the possibility of contamination by foreign material.

2.2 Plumbing Hook-Up

Backflush discharge pipe should be 2 inches in diameter if line is less than 20 feet long with no more than one elbow; pipe with 2-1/2 inches or 3 inches in diameter should be used if line is longer and may be manifolded if desired. Any restrictions in the backflush line will reduce the cleaning ability of the filter.

The incoming line should have a minimum 1 in. air vent vacuum relief valve installed to prevent water hammer. Discharge lines should never run uphill. This will affect the required pressure differential and reduce cleaning.

Strongly Recommended: A block valve should be installed immediately upstream of the filter. During start-up, the block valve should only be barely cracked open to prevent a surge of pressure across the filter once the pump is started. Once the pump is on-line, slowly open the block valve. This would prevent any possible damage to the filter due to a pressure surge. It is also recommended that a block valve be installed downstream of the filter which would enable the filter to be isolated for service.

2.3 Electronic Controller Hook-Up (See drawing on Page I5)

Before power is applied to the electronic controller, make all connections between controller and solenoid valves.

1. **SOLENOID CHECK OUT** - using appropriate power source to energize switch and proceed as follows: put ear close to solenoid, trip switch and listen for a "click" open and a "click" shut.
2. **FLUSHING TIME ADJUSTMENT** - the flush time is normally set for five seconds. For difficult contaminants, it may be increased to six seconds or longer.
3. **PRESSURE DIFFERENTIAL ADJUSTMENT** - the triggering differential is pre-set for 7 psi. It can be changed to different setpoints (see your rinse controller manual).

Using 1/8 - 1/4 inch diameter tubing:

1. Attach tubing to Port #1 on solenoid valve port and attach other end to fitting on the bottom of flushing valve bonnet.
2. Attach tubing to Port #2 on solenoid valve port and attach other end to an air or water supply source.
3. Attach tubing to fitting on clean water outlet and attach other end to fitting on rinse controller marked "low pressure".
4. Attach tubing to fitting on rinse controller marked "high pressure" and attach other end to fitting on dirty water inlet.

Important Note: Do not run tubing more than three feet in length (preferably two feet or less). Due to the pressure drop across the tubing, the electronic rinse controller may not operate properly if tubing is too long.

SECTION III OPERATION AND ADJUSTMENTS

3.1 Start-Up

During the initial filling of the main pipeline, there may not be enough back pressure downstream from filter to allow the cleaning cycle to function properly. Therefore, it is necessary to install a valve on the outlet line to be partially closed (e.g. gate valve, ball valve or butterfly valve).

If a downstream main line valve is partially closed, enough to provide 35 psi on filter pressure gauges, the self-cycle will operate properly. Once the total system is fully charged, the downstream valve can be adjusted as the system requires, as long as 35 psi is maintained at the filter.

If systems are to come on automatically, it is advisable to install a flow control or pressure sustaining valve downstream from the filters to create back pressure on the filters in order to enable proper flushing while pipe lines are being filled.

3.2 Pressure Differential Adjustment

The hydraulic controller has only one adjustment - a small brass screw with a locking nut, located at the top of the upper bulkhead. After the lock nut is loosened, the screw can be turned by finger pressure. The controller is factory adjusted to 7 psi differential. If field adjustment is necessary, loosen the lock nut and turn the screw counter clockwise until the filter flushes. When the filter is clear (4 - 6 seconds), turn clockwise one or two turns and wait for the flushing valve to close. When the flush valve has closed, turn screw counterclockwise slowly until the emitter on the side of the controller just starts to drip. Now each full turn clockwise will produce approximately 3 psi differential. Re-tighten locking nut to hold setting.

SECTION IV MAINTENANCE

4.1 Filter Cleaning

Periodic cleaning of the pre-strainer is necessary for removal of large particles trapped in the chamber. Proceed as follows:

1. Turn inlet water off.
2. Relieve any pressure on downstream side of filter.
3. Unbolt clamp and remove lid.
4. Remove pre-strainer cap.
5. Remove pre-strainer.

4.2 Filter Replacement

If the filter element should ever need replacing, follow steps outlined in Section 4.1 (Filter cleaning) and continue as follows:

1. Grasp flushing mechanism firmly and remove with quick jerking motion.
2. If flushing mechanism is not easily removed by method described above, prying may be required as follows:
 - a. Pass a line (rope etc.) through two opposing holes in the pre-strainer and tie ends together, creating a loop approximately one foot long.
 - b. Place a piece of wood (approximately 2 in. x 4 in. x 14 in.) across the face of the tank for protection.
 - c. Insert a lever in the loop and pry against the wood until the screen breaks loose from its seal (approximately 1/4 in.) after which removal will be easy.
3. Disassemble fine filter element (see Page 13).
4. Grease all o-rings with waterproof "O" ring lubricant.
5. Re-assemble unit (reverse procedure).
6. Turn inlet water on.

NOTE: A 1/4 inch open end, box wrench or an adjustable crescent wrench will be required for this change over.

SECTION V TROUBLESHOOTING GUIDE

5.1 Problem: Flushing valve does not close during start-up.

POSSIBLE CAUSE

System pressure is too low to close.

SOLUTION

Partially close a mainline valve downstream of the filter to maintain 25 psi on filter gauges. This pressure will ensure valve closure and also supply back pressure necessary to clean the screen.

5.2 Problem: Excessive pressure drop through filter without flushing.

POSSIBLE CAUSES

1. Controller is not turned on.
2. Flushing valve is installed backwards.
3. Filter is installed backwards.
4. Electronic controller is hooked up with a common negative instead of a common positive. A common negative causes all solenoids to stay open.

SOLUTION

1. Turn on power.
2. Install according to directional arrow.
3. Install pressure line to leg marked inlet.
4. See Pressure Differential Adjustment, Section 3.2, page 6.
5. See Electronic Control Connection fig. 6.5, page 15.

5.3 Problem: Flushing valve chatter.

POSSIBLE CAUSE

Air in the valve bonnet.

SOLUTION

1. Point bonnet "skyward" (to vent trapped air).
2. Manually flush filter several times to flush air from the bonnet, the controller tank and the filter tank.
3. Add a 1/2 or 1 inch air vent/vacuum relief to the flush line.

5.4 Problem: Flushing valve stays open.

POSSIBLE CAUSES

1. Hole in flush valve diaphragm.
2. Dirt in solenoid valve.

SOLUTION

1. Disassemble solenoid valve, open flush valve and replace valve diaphragm.
2. Disassemble solenoid valve and clean.

5.5 Problem: Frequent or continuous flushing while filling main pipeline.

POSSIBLE CAUSES

1. Downstream pressure is not available to provide vacuum cleaning power.
2. Rapid-filling flow rate exceeds the controllers' pressure differential.

SOLUTION

Partially close downstream mainline valve; filter gauges should read 25 psi.

POSSIBLE CAUSE

Filter may have been shut down "dirty," with a contaminant that is difficult to remove after it dries on the screen.

SOLUTION

A super flush needs to be performed as follows: a downstream mainline valve should be adjusted providing that the static pressure against the valve does not exceed 80 psi. After the valve is adjusted, cycle the filter through several "long" flushings. This process uses the entire available differential pressure in the filter cleaning process.

5.6 Problem: Frequent flushing during normal operation.

POSSIBLE CAUSE

Very dirty water.

SOLUTION

Increase flushing time to 6 seconds or more.

POSSIBLE CAUSE

The controller pressure differential is set too close causing vibration to initiate a flush cycle.

SOLUTION

Increase pressure differential (see Page 2 for both electronic and hydraulic controller).

POSSIBLE CAUSE

Screen may be partially plugged.

SOLUTION

Perform super flush as described above.

POSSIBLE CAUSE

Rotor may be jammed which results in only cleaning the screen area that is directly in front of the nozzles.

SOLUTION

Open tank and check for free movement of rotor mechanism.

POSSIBLE CAUSE

Pre-strainer is contaminated.

SOLUTION

While running, check pressure between filter inlet and filter outlet, use port provided on waste nipple. The difference between these two readings is the pressure drop through the pre-strainer. It should be zero.

5.7 Problem: When changing irrigation blocks, filter flushes rapidly.

POSSIBLE CAUSE

Water flow in new block is causing an increased pressure drop through filter which exceeds the controller setting.

SOLUTION

Re-adjust controller for the highest flow rate. (See pages 2 and 3).

5.8 Problem: Screen will not clean properly.

POSSIBLE CAUSE

The flush cycle might be set too short (5 seconds is normal). Flushing valve does not open fully.

SOLUTION

Restriction in flushing valve dump line due to long "run" distance, running uphill, 2" line more than 20' long, 2" line has more than one elbow.

POSSIBLE CAUSE

Filter was shut down "dirty" with contaminant drying on the screen.

SOLUTION

Perform super flush as described on Section 5.5, page 9. If unsuccessful, remove filter, see Page 5 and soak in swimming pool acid solution (1 qt. muriatic acid to 5 gal. water) for 15 minutes. Then spray the filter with a high pressure hose to remove the contaminant. After reinstalling the filter, perform another super flush.

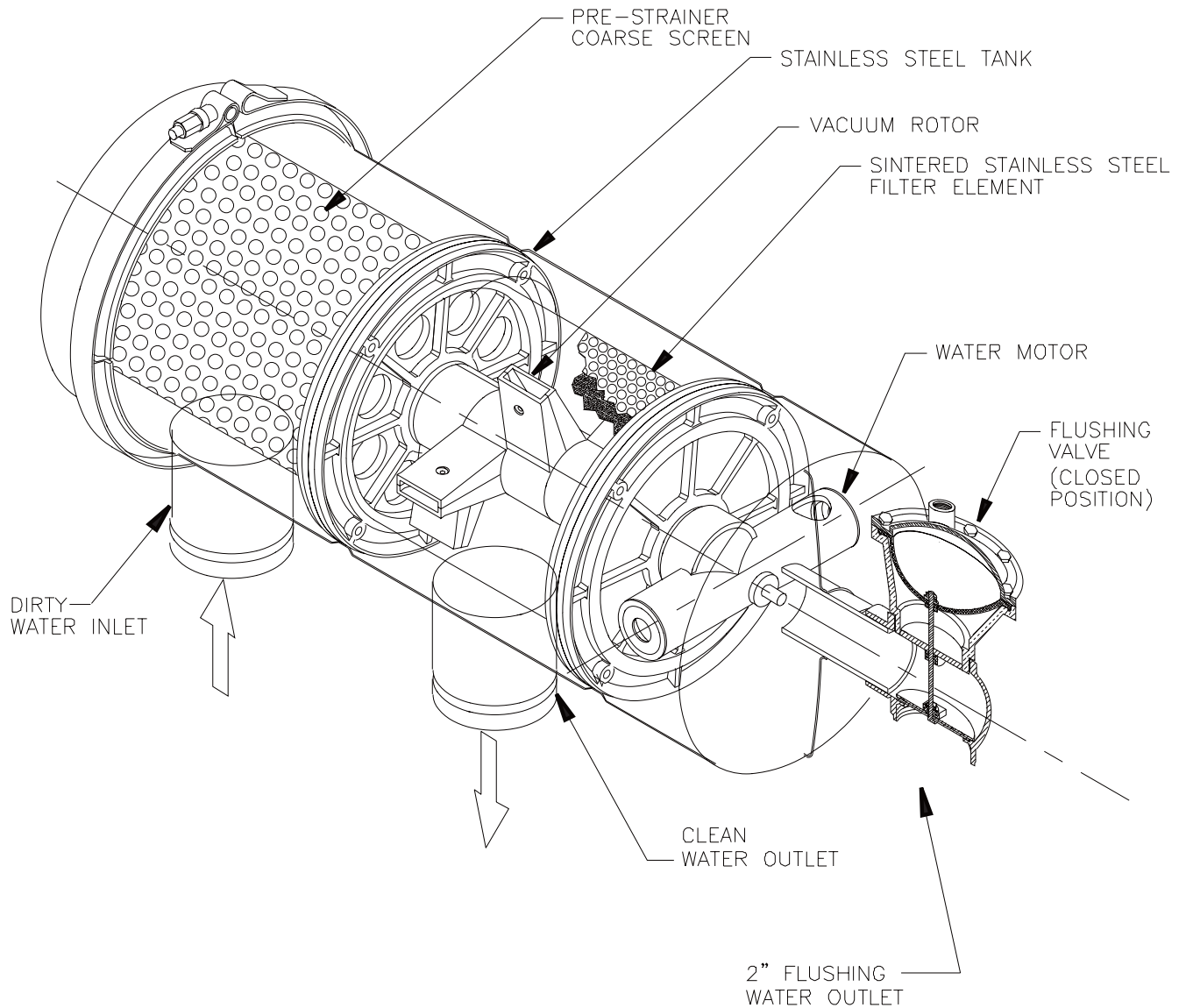

AUTOMATIC FILTERS INC.

FILTER ASSEMBLY

For more information:

WEB: FLTR.com.au PHONE: (+61) 1300 62 4020 EMAIL: info@FLTR.com.au SKYPE: Purple.Engineering



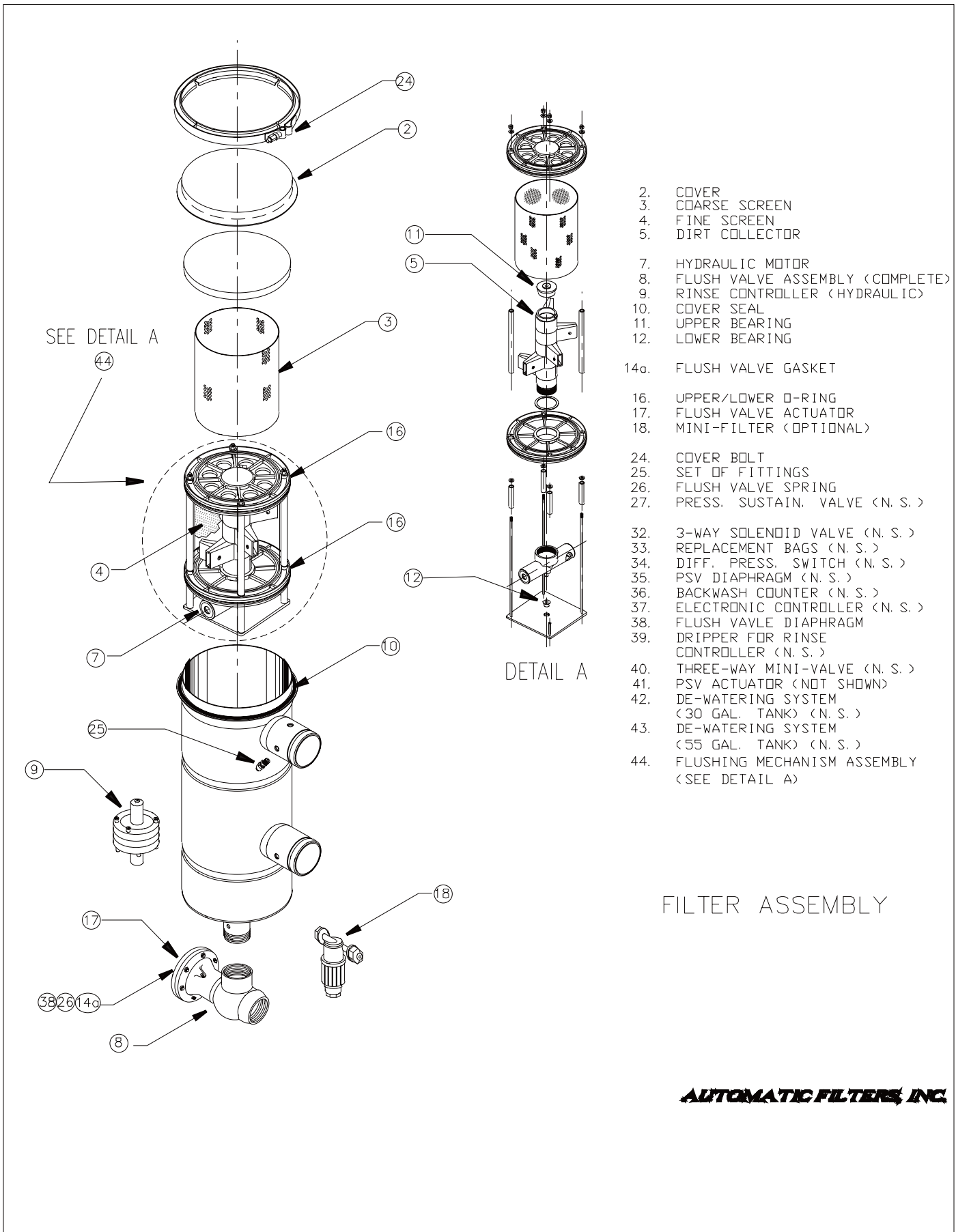

- 2. COVER
- 3. COARSE SCREEN
- 4. FINE SCREEN
- 5. DIRT COLLECTOR
- 7. HYDRAULIC MOTOR
- 8. FLUSH VALVE ASSEMBLY (COMPLETE)
- 9. RINSE CONTROLLER (HYDRAULIC)
- 10. COVER SEAL
- 11. UPPER BEARING
- 12. LOWER BEARING
- 14a. FLUSH VALVE GASKET
- 16. UPPER/LOWER O-RING
- 17. FLUSH VALVE ACTUATOR
- 18. MINI-FILTER (OPTIONAL)
- 24. COVER BOLT
- 25. SET OF FITTINGS
- 26. FLUSH VALVE SPRING
- 27. PRESS. SUSTAIN. VALVE (N. S.)
- 32. 3-WAY SOLENOID VALVE (N. S.)
- 33. REPLACEMENT BAGS (N. S.)
- 34. DIFF. PRESS. SWITCH (N. S.)
- 35. PSV DIAPHRAGM (N. S.)
- 36. BACKWASH COUNTER (N. S.)
- 37. ELECTRONIC CONTROLLER (N. S.)
- 38. FLUSH VALVE DIAPHRAGM
- 39. DRIPPER FOR RINSE CONTROLLER (N. S.)
- 40. THREE-WAY MINI-VALVE (N. S.)
- 41. PSV ACTUATOR (NOT SHOWN)
- 42. DE-WATERING SYSTEM (30 GAL. TANK) (N. S.)
- 43. DE-WATERING SYSTEM (55 GAL. TANK) (N. S.)
- 44. FLUSHING MECHANISM ASSEMBLY (SEE DETAIL A)

FILTER ASSEMBLY

AUTOMATIC FILTERS, INC.

For more information:

WEB: FLTR.com.au PHONE: (+61) 1300 62 4020 EMAIL: info@FLTR.com.au SKYPE: Purple.Engineering



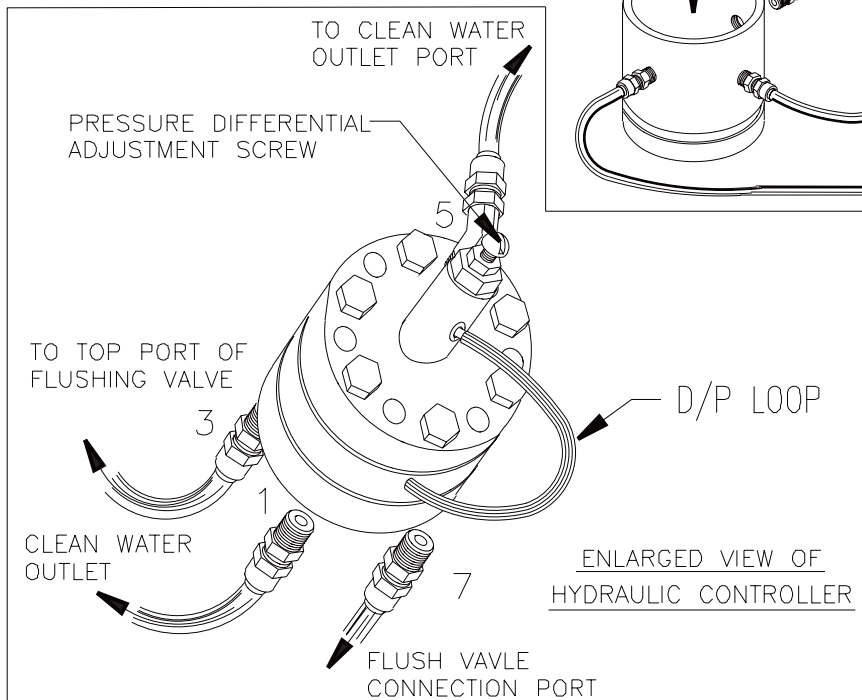
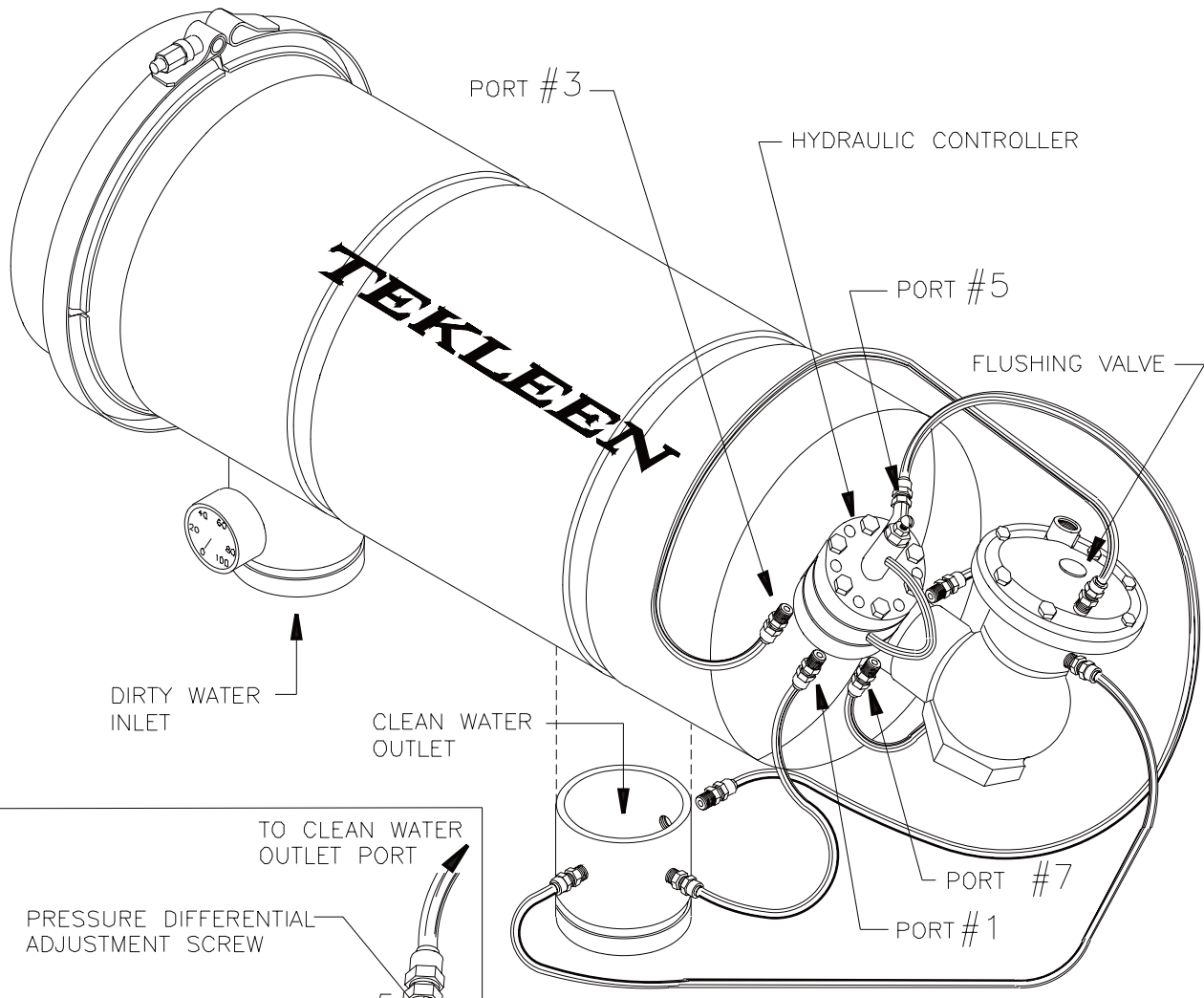

AUTOMATIC FILTERS, INC.
 2672 S. La Cienega Boulevard
 Los Angeles, CA 90034
 (800) 336-1942
 (310) 839-2828
 FAX (310) 839-6878

HYDRAULIC CONTROLLER CONNECTIONS

For more information:

WEB: FLTR.com.au PHONE: (+61) 1300 62 4020 EMAIL: info@FLTR.com.au SKYPE: Purple.Engineering



2672 S. La Cienega Boulevard
 Los Angeles, CA 90034
 (800) 336-1942
 (310) 839-2828
 FAX (310) 839-6878

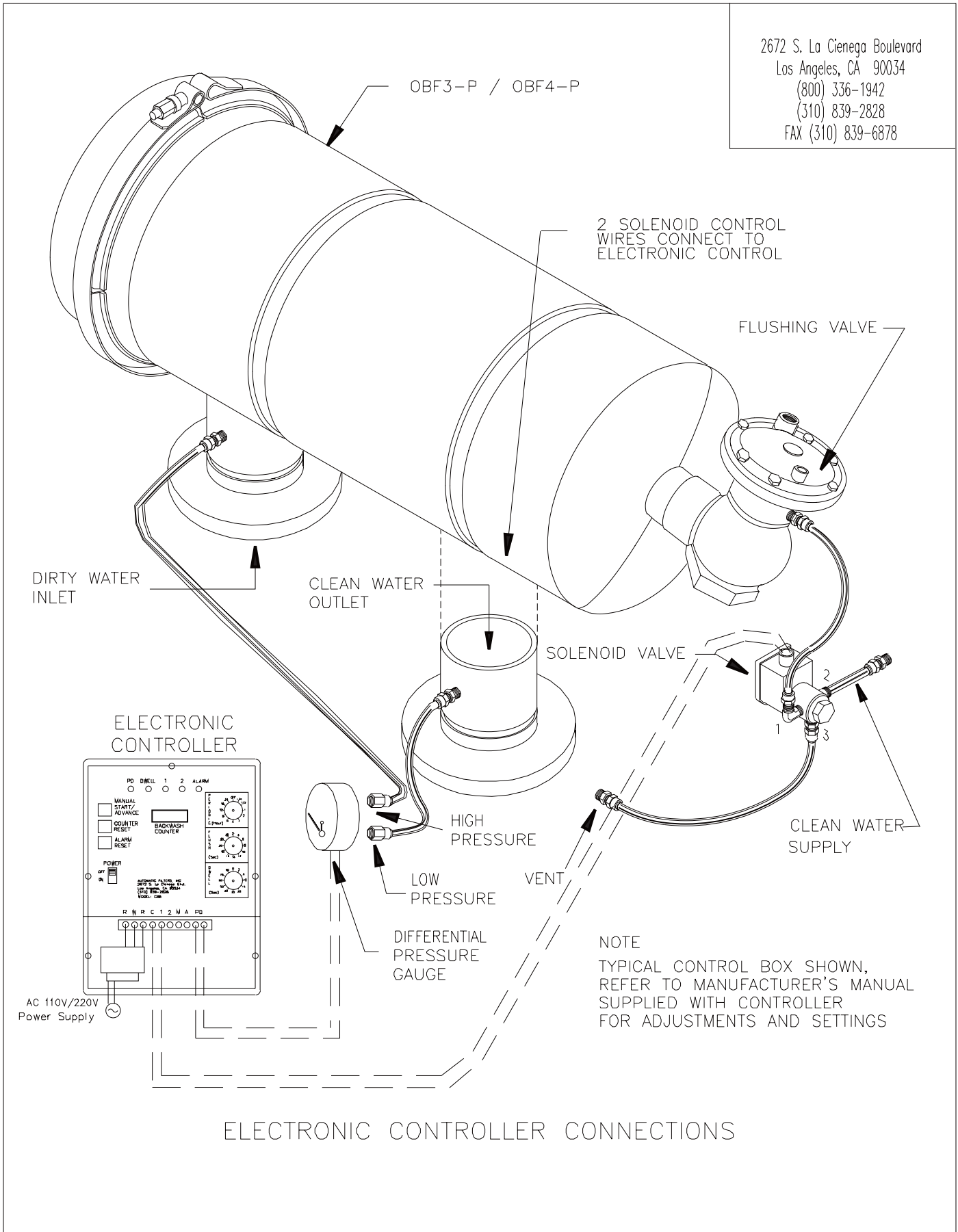

For more information:

WEB: FLTR.com.au PHONE: (+61) 1300 62 4020 EMAIL: info@FLTR.com.au SKYPE: Purple.Engineering



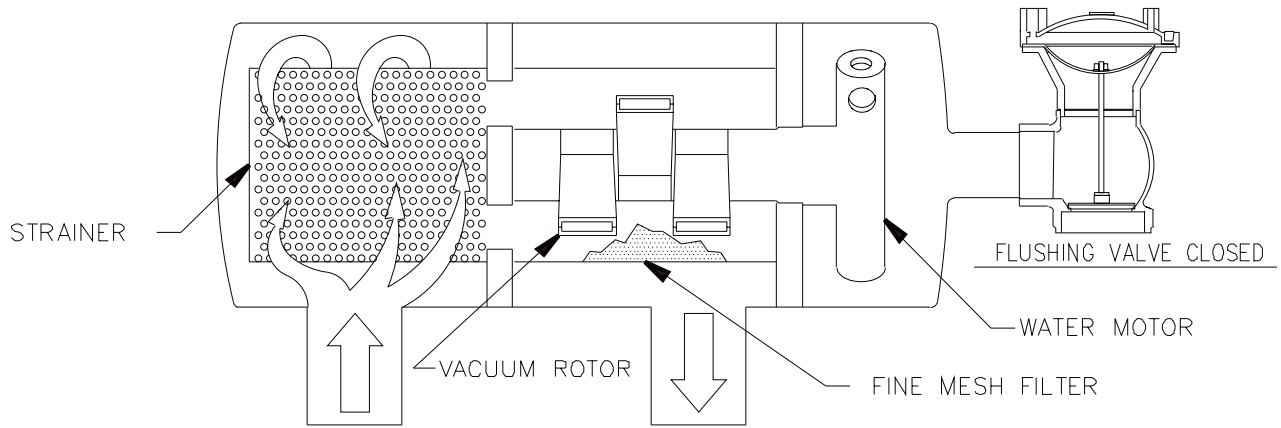

1. DIRTY WATER ENTERS STRAINER AND LARGE PARTICLES ARE REMOVED AND DEPOSITED ON THE EXTERIOR OF THE STRAINER

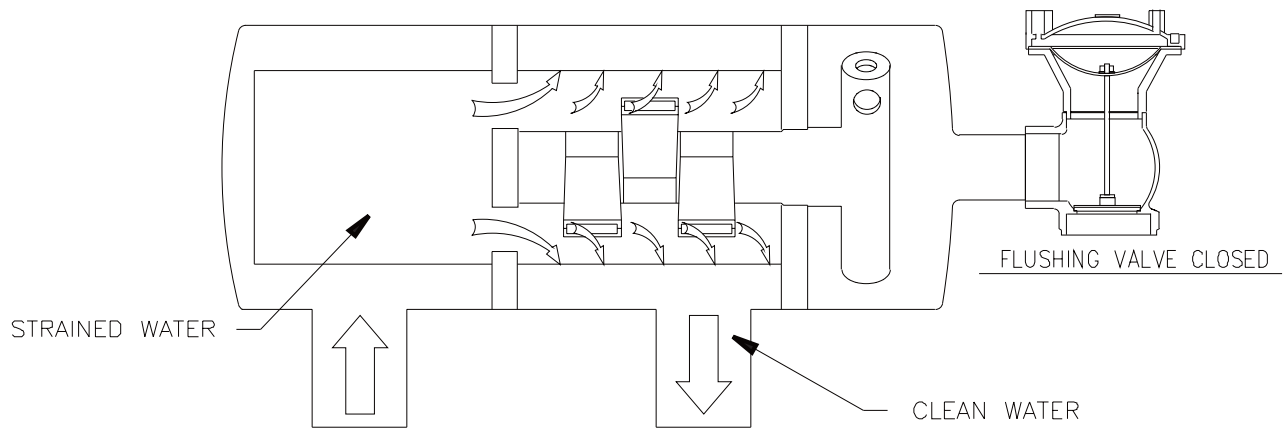

2. STRAINED WATER ENTERS FINE MESH FILTER AND CLEAN WATER FLOWS OUT TO IRRIGATION SYSTEM

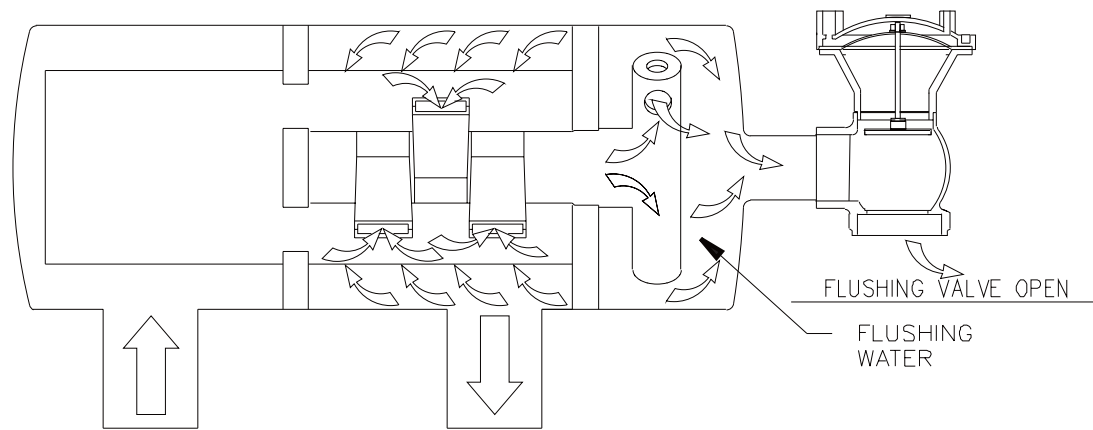

3. DEBRIS IS REMOVED FROM INTERIOR OF THE FILTER BY THE VACUUM ROTOR AND FLOWS OUT THE FLUSHING VALVE

FILTERING & FLUSHING SEQUENCE

AUTOMATE FILTERS INC

For more information:

WEB: FLTR.com.au PHONE: (+61) 1300 62 4020 EMAIL: info@FLTR.com.au SKYPE: Purple.Engineering



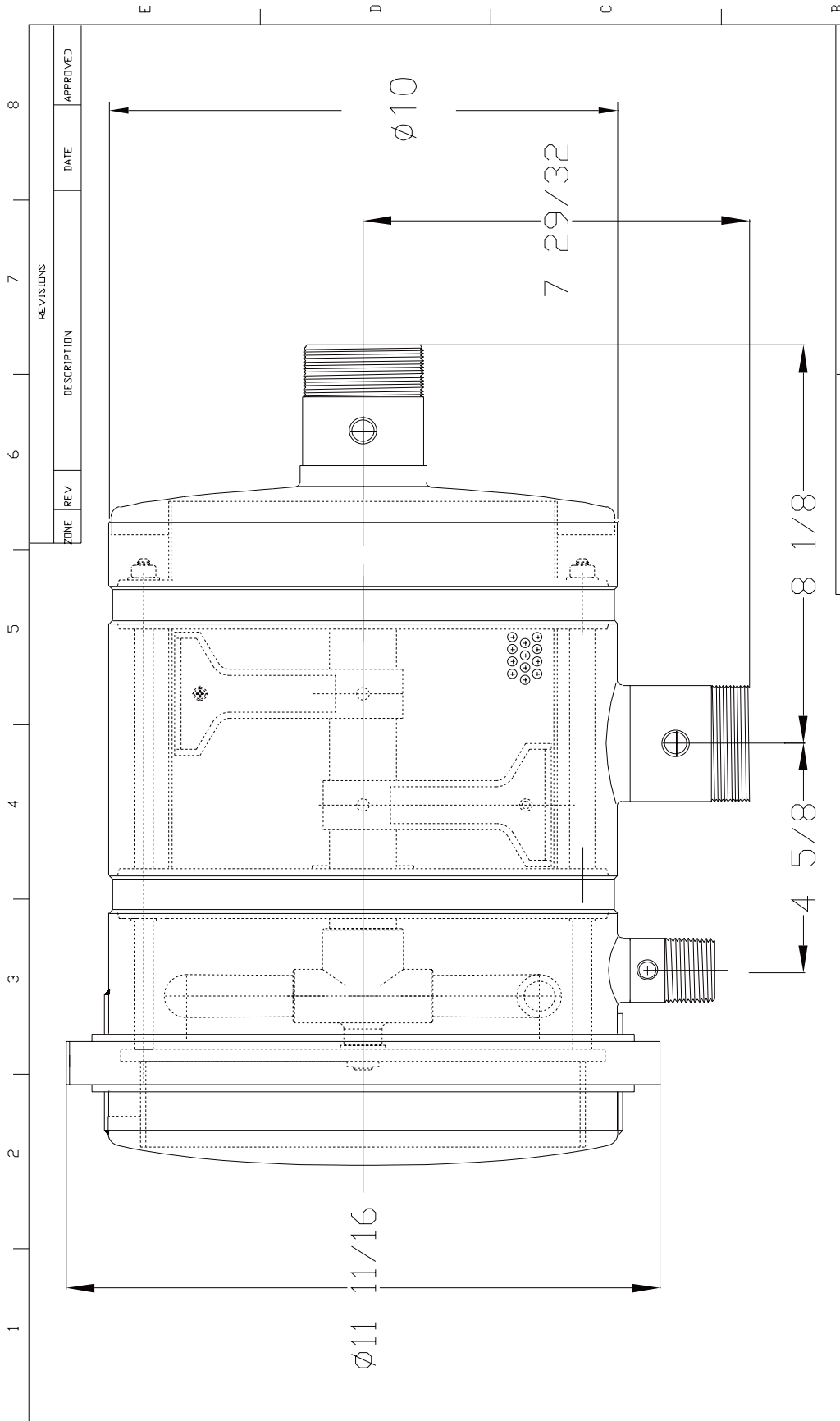

UNLESS OTHERWISE SPECIFIED DIMENSIONS ARE IN INCHES DECIMALS ANGULAR .XX ± .05 ± .05 DEG. .XXX ± .01		DATE 5/8/02	
DRAWN JAE H. JI		CHECKED	
DESIGN		TITLE 2" DBF FILTER	
SIZE A	DRG NO. 2INCHFILTER	REV 0	SHEET OF
scale 1:14		SHEET DF	

- NOTES:
- 1.MATERIAL: 316 STAINLESS STEEL AND ENGINEERING GRADE PLASTIC
 - 2.DIMENSIONS SUBJECT TO CHANGE WITHOUT NOTICE
 - 3.DRAWING NOT TO SCALE
 - 4.FOR REFERENCE ONLY

For more information:

WEB: FLTR.com.au PHONE: (+61) 1300 62 4020 EMAIL: info@FLTR.com.au SKYPE: Purple.Engineering

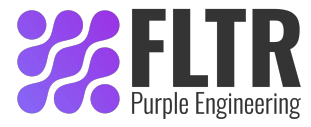

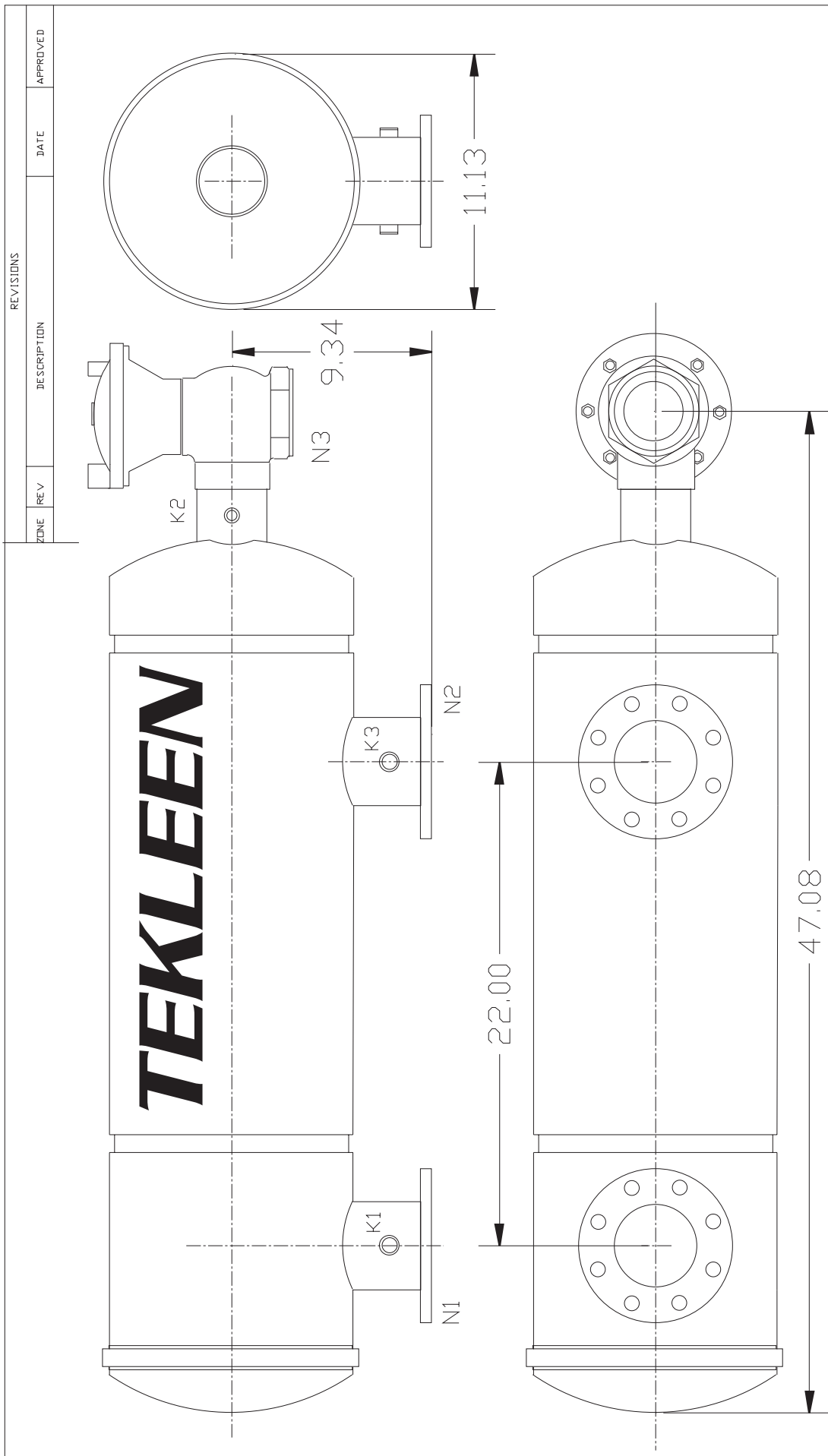

UNLESS OTHERWISE SPECIFIED DIMENSIONS ARE IN INCHES TOLERANCES DECIMALS .XX ± .05 ANGULAR .XXX ± .01		DATE 1/3/02	
DRAWN JAE H. JI		CHECKED	
DESIGN		TITLE OBF4-P FLANGED Stainless Steel	
SIZE A	DWG NO. OBF4-P	REV 0	
SCALE 1:6		SHEET 1 OF 1	

ZONE	REV	DESCRIPTION	DATE	APPROVED

NOZZLE	CONNECTION	TYPE	SIZE
N1	INLET	FLANGED	4" ASA
N2	OUTLET	FLANGED	4" ASA
N3	FLUSH OUTLET	THREADED	2" NPT
K1	Hi Pres. Conn.	THREADED	1/4" NPT
K2	Back Wash	THREADED	1/8" NPT
K3	Low Pressure	THREADED	1/4" NPT

FLOWRATE: MAX. 500 GPM
 MAX. PRESS: 125 PSI
 SCREEN SIZE: 10-400 MICRON
 SCREEN AREA: 30 SQ.FT.
 MAX. TEMP: 140 F (AVAIL. TO 210 F)
 WEIGHT: 90 LBS

For more information:

WEB: FLTR.com.au PHONE: (+61) 1300 62 4020 EMAIL: info@FLTR.com.au SKYPE: Purple.Engineering



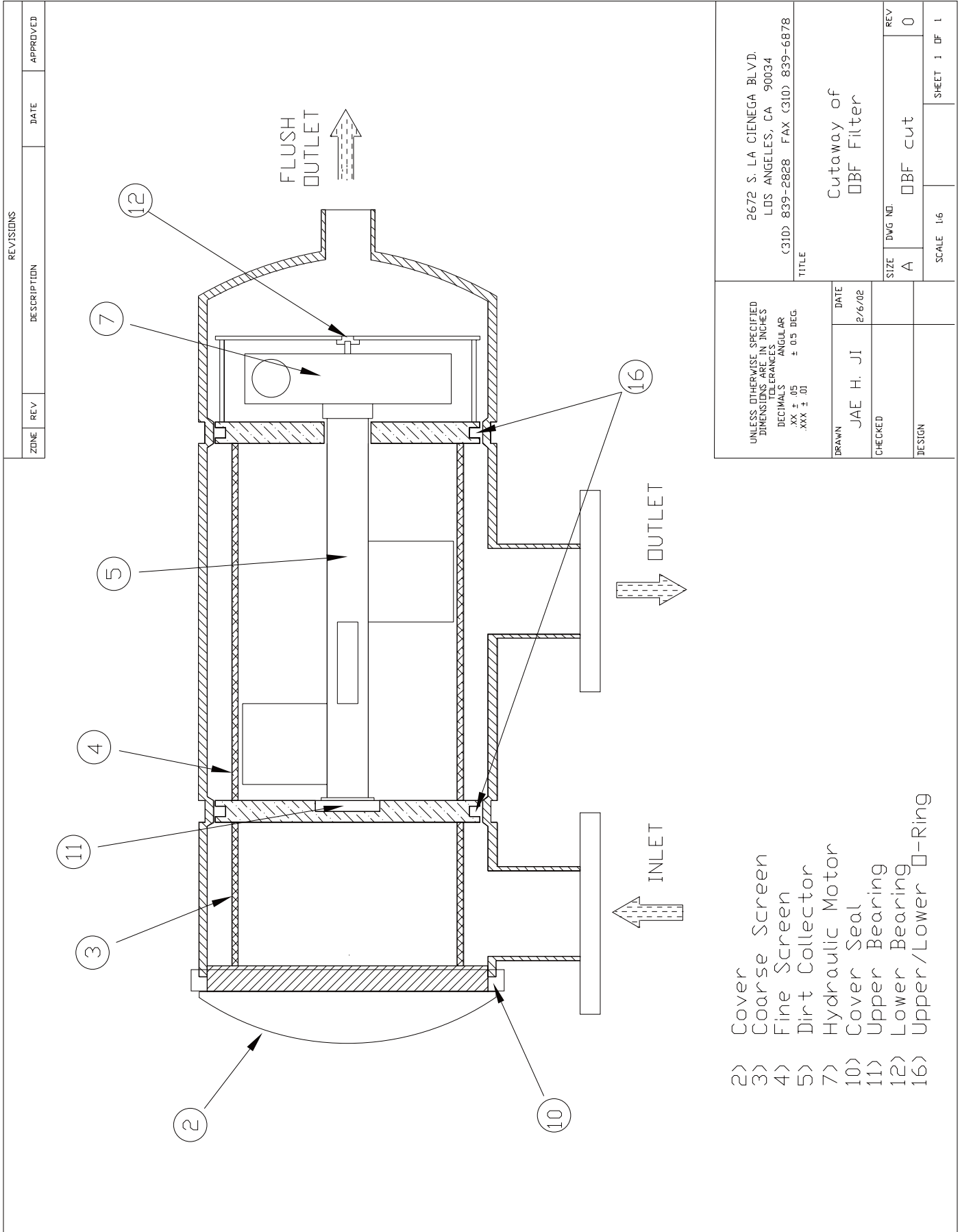

For more information:

WEB: FLTR.com.au PHONE: (+61) 1300 62 4020 EMAIL: info@FLTR.com.au SKYPE: Purple.Engineering



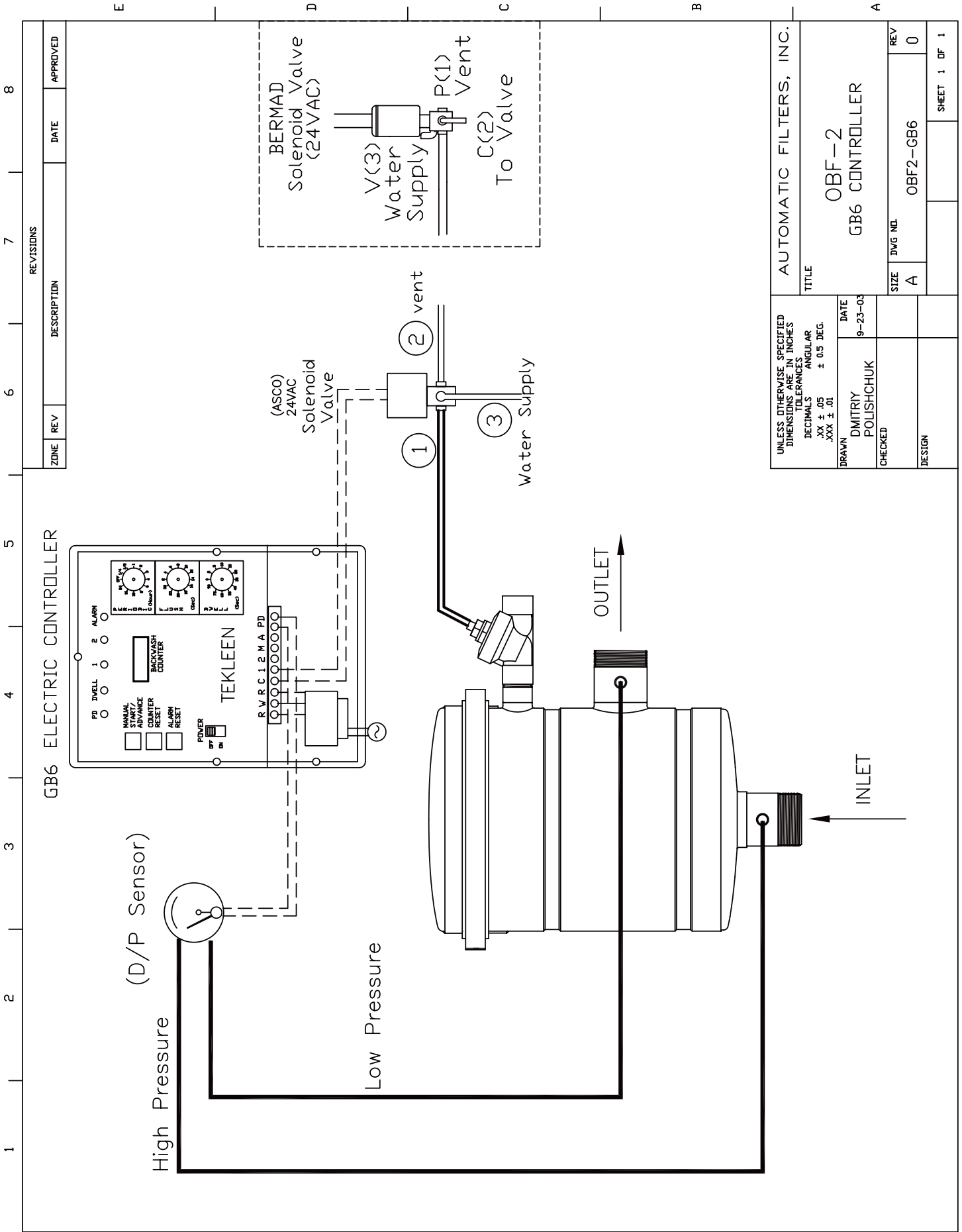

UNLESS OTHERWISE SPECIFIED DIMENSIONS ARE IN INCHES DECIMALS ARE ANGULAR		TITLE	
XX ± .05	± 0.5 DEG.	AUTOMATIC FILTERS, INC.	
.XXX ± .01		OBF-2	
DRAWN DMITRIY POLISHCHUK		DATE 9-23-03	REV 0
CHECKED		SIZE A	REV 0
DESIGN		DWG NO. OBF2-GB6	SHEET 1 OF 1

For more information:

WEB: FLTR.com.au PHONE: (+61) 1300 62 4020 EMAIL: info@FLTR.com.au SKYPE: Purple.Engineering



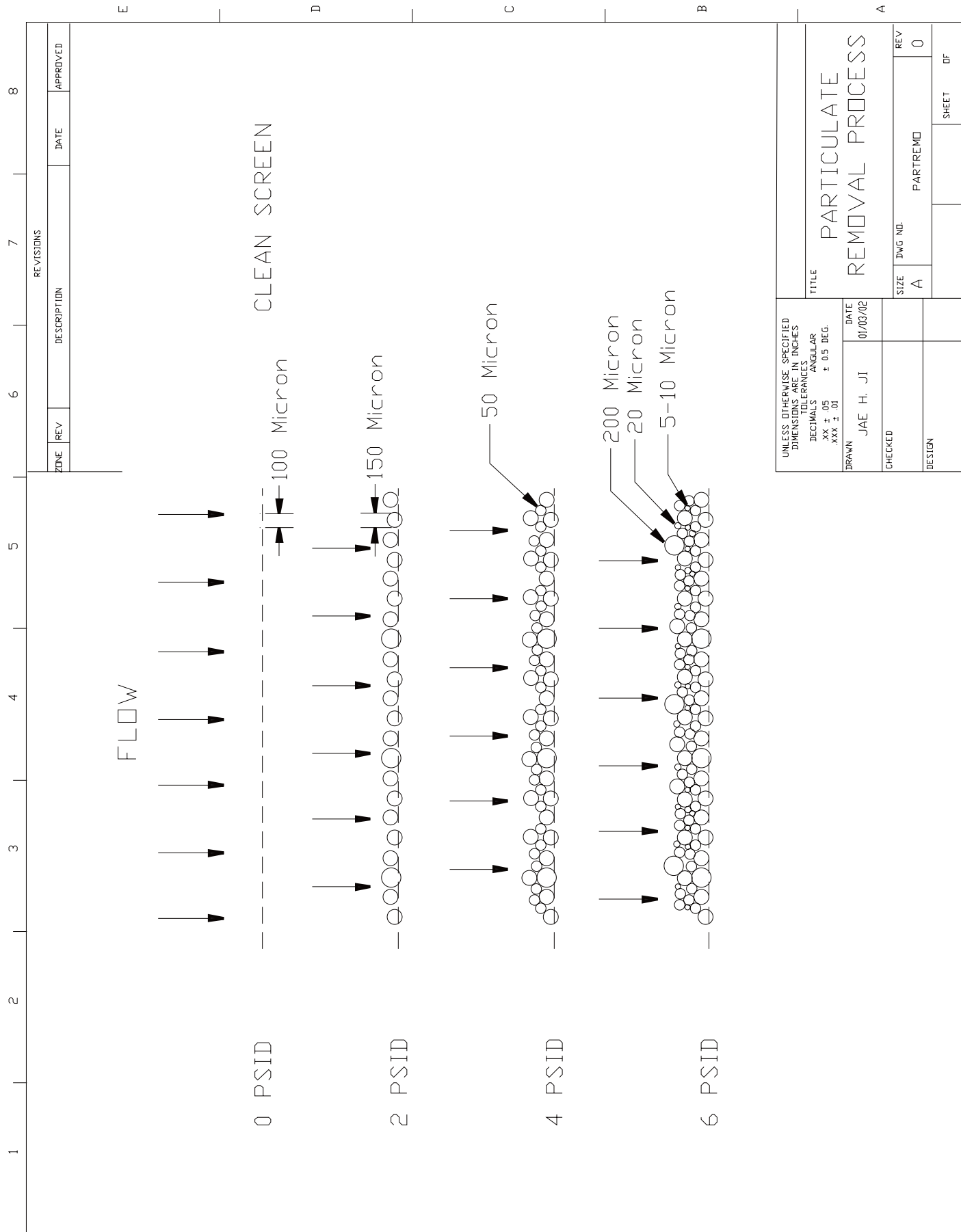

UNLESS OTHERWISE SPECIFIED
 DIMENSIONS ARE IN INCHES
 DECIMALS ANGULAR
 XX ± .05 ± 0.5 DEG.
 XXX ± .01

TITLE	PARTICULATE REMOVAL PROCESS		
DRAWN	JAE H. JI	DATE	01/03/02
CHECKED		SIZE	A
DESIGN		DWG NO.	
		REV	0
		PARTNO	
		SHEET	OF

For more information:

WEB: FLTR.com.au PHONE: (+61) 1300 62 4020 EMAIL: info@FLTR.com.au SKYPE: Purple.Engineering



PRESSURE DROP DATA

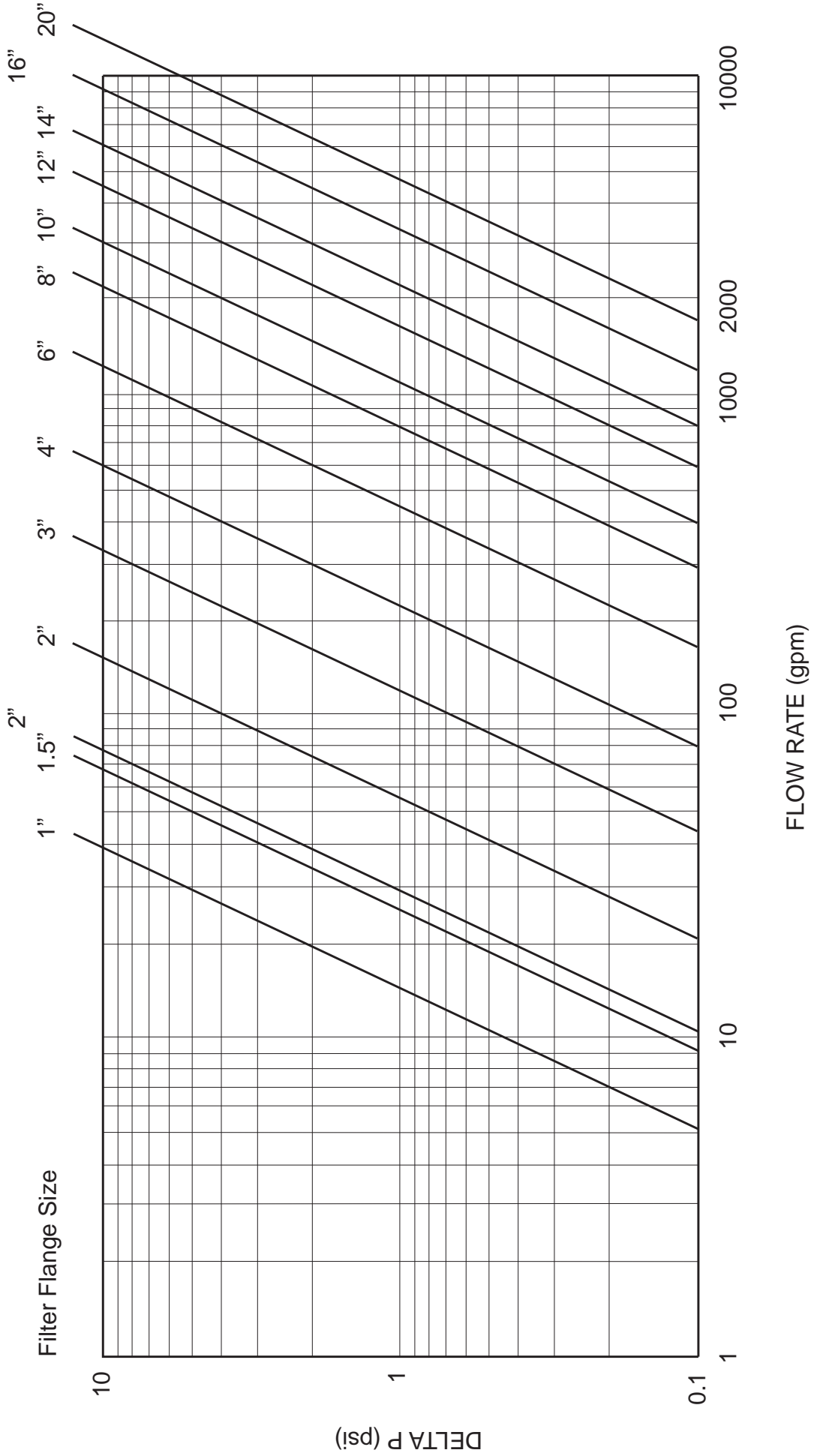

For more information:

WEB: FLTR.com.au PHONE: (+61) 1300 62 4020 EMAIL: info@FLTR.com.au SKYPE: Purple.Engineering

