

1 2 3 4 5 6 7 8

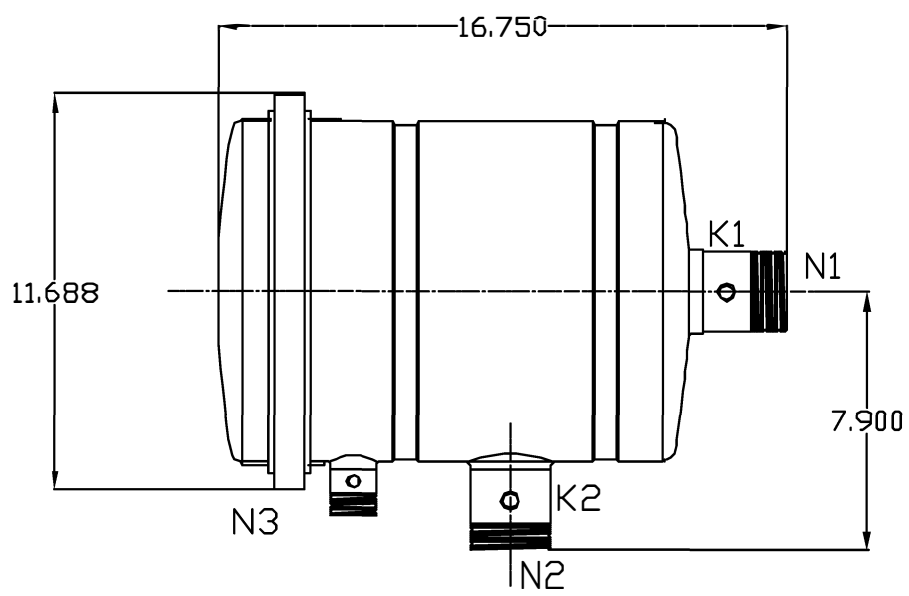

REVISIONS				
ZONE	REV	DESCRIPTION	DATE	APPROVED

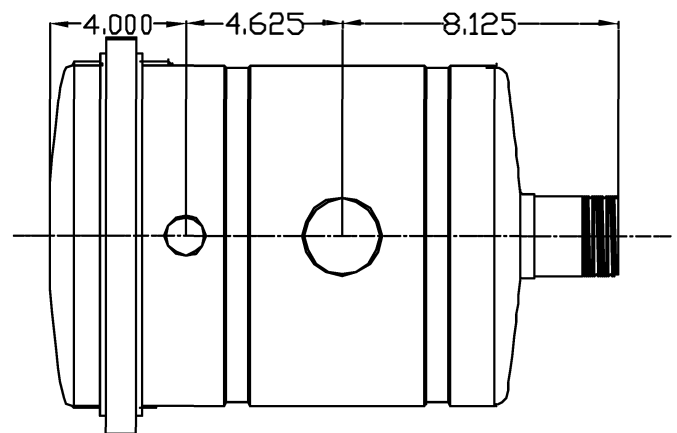
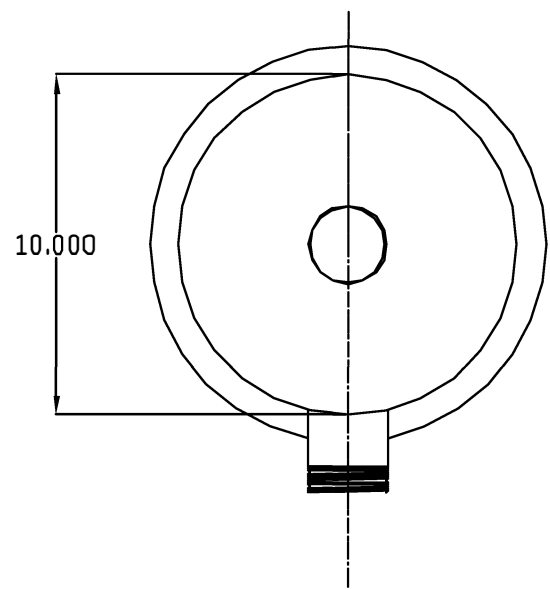

NOZZLE	CONNECTION	TYPE	SIZE
N1	INLET	THREADED	2" NPT
N2	OUTLET	THREADED	2" NPT
N3	FLUSH OUTLET	THREADED	1" NPT
K1	HI Pres. Conn	THREADED	1/4" NPT
K2	Low Pres.	THREADED	1/4" NPT

FLOWRATE: MAX. 125 GPM
 MAX. PRESS.: 125 PSI
 SCREEN SIZE: 10-400 MICRON
 SCREEN AREA: 0.8 SQ.FT.
 MAX. TEMP: 140 F (AVAIL. TO 210 F)
 WEIGHT: 50 LBS

UNLESS OTHERWISE SPECIFIED
 DIMENSIONS ARE IN INCHES
 TOLERANCES

DECIMALS	ANGULAR
.XX ± .05	± 0.5 DEG.
.XXX ± .01	



FLTR
Purple Engineering

DRAWN		DATE	
Daniel Stenberg		6-2-05	
CHECKED		TITLE	
		QBF 2	
SIZE	DWG. NO.	REV	
A	QBF 2	1	
NTS		SHEET OF	