

REVISIONS				
ZONE	REV	DESCRIPTION	DATE	APPROVED

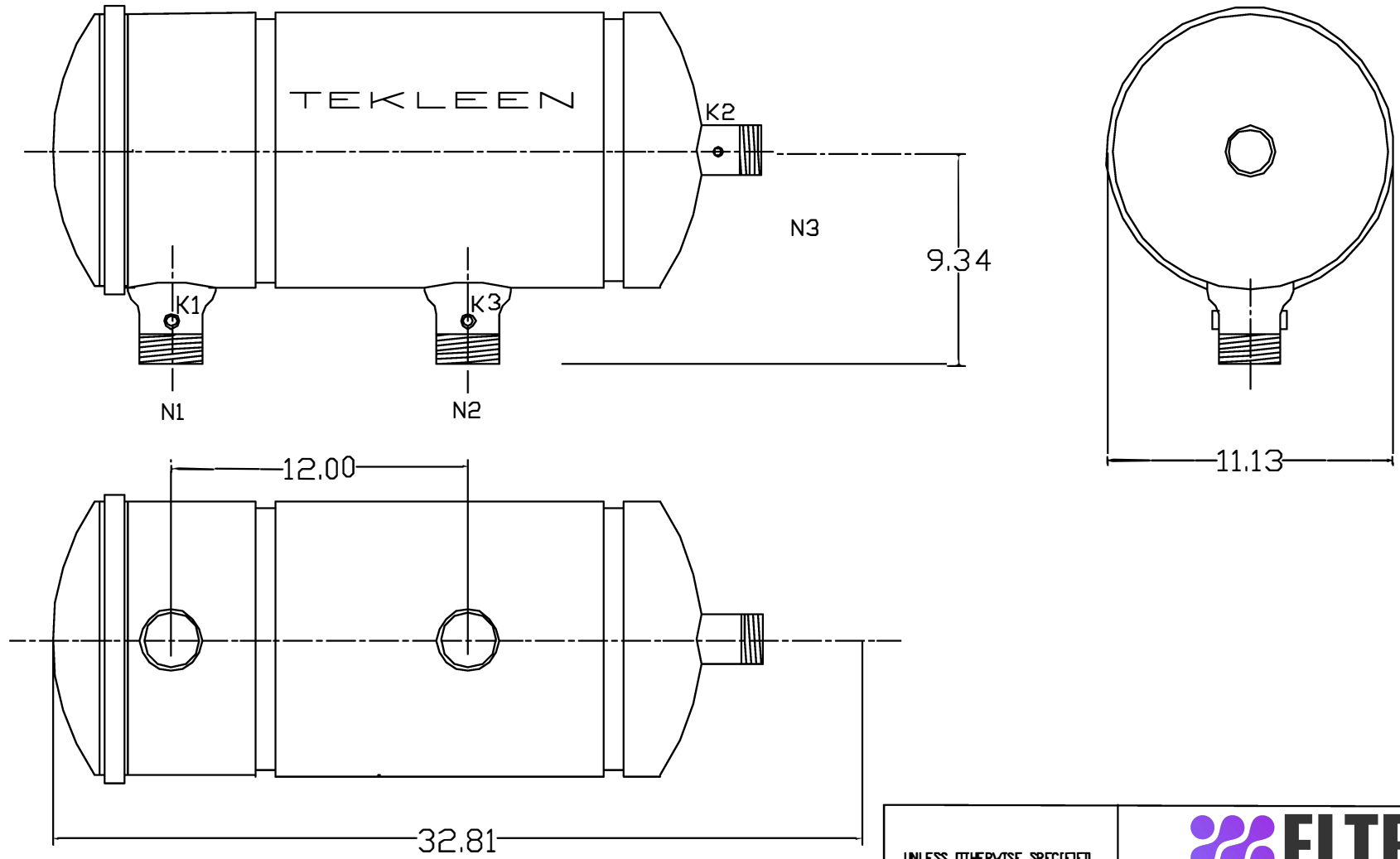

NOZZLE	CONNECTION	TYPE	SIZE
N1	INLET	THREADED	2" ASA
N2	OUTLET	THREADED	2" ASA
N3	FLUSH OUTLET	THREADED	2" NPT
K1	Hi Pres. Conn.	THREADED	1/4" NPT
K2	BackWash P.	THREADED	1/8" NPT
K3	Low Pres.	THREADED	1/4" NPT

FLOW RATE: MAX. 200 GPM  
 MAX. PRESS.: 125 PSI  
 SCREEN SIZE: 5-400 MICRON  
 SCREEN AREA: 1.5 SQ.F.T.  
 MAX. TEMP.: 140 F (AVAIL. TO 210 F)  
 WEIGHT: 75 LBS.

UNLESS OTHERWISE SPECIFIED  
DIMENSIONS ARE IN INCHES

TOLERANCES

DECIMALS	ANGULAR
XX ± .05	± 0.5 DEG.
XXX ± .01	

DRAWN	DATE
Daniel Stenberg	4-8-05
CHECKED	
DESIGN	



TITLE

OBF2-P

SIZE	DWG NO.	REV
A	OBF2-P	1
NTS		SHEET 1 OF 1