

REVISIONS				
REV.	ZONE	DESCRIPTION	DATE	INITIAL

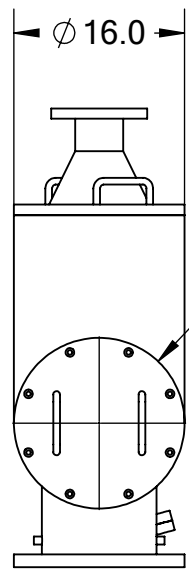

FRONT VIEW

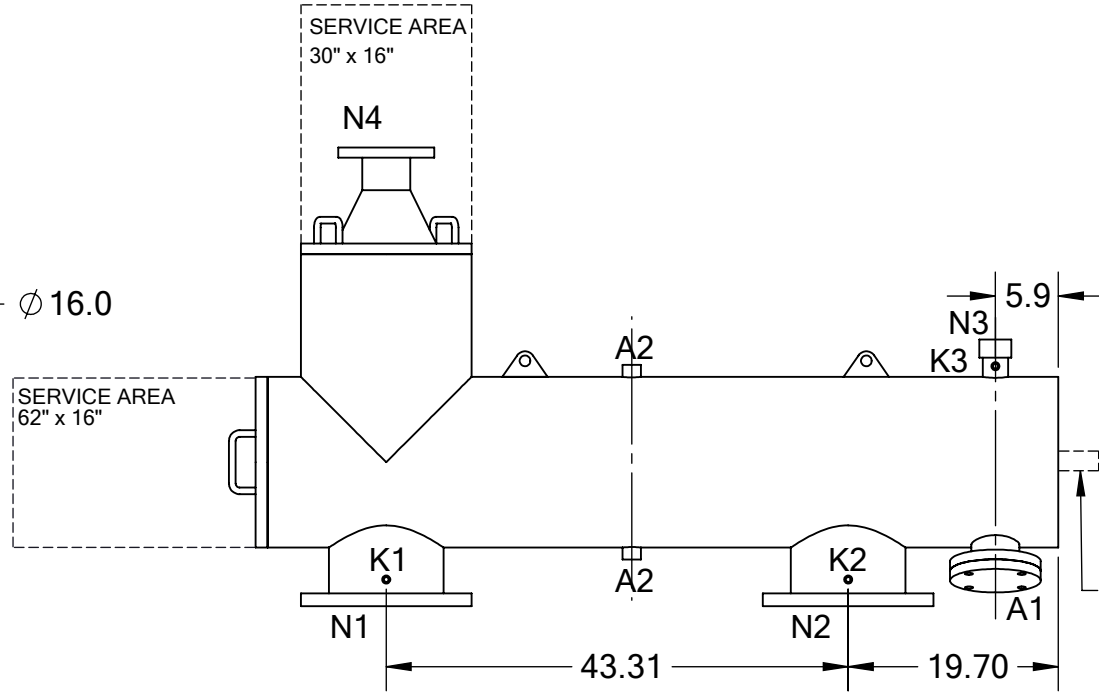

SIDE VIEW

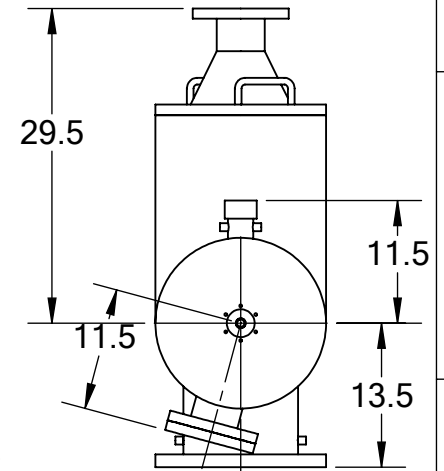

BACK VIEW

NOTE 1.

TECHNICAL DATA

	ABW	CSF
FLOW RATE	MAX. 1,750 GPM	(397 m ³ /hr)
SCREEN SIZE	___ MICRON	___ SLOT
SCREEN AREA	11.0 SQ. FEET	8.5 SQ. FEET
DESIGN TEMPERATURE	160 °F	160 °F
DESIGN PRESSURE	150 PSI	150 PSI
EMPTY WEIGHT	~750 LBS.	
FULL WEIGHT	~1,400 LBS.	

- NOTES:**
 1. PLEASE ALLOW ~20" ADDITIONAL TO INSTALL AND REMOVE THE PISTON ASSEMBLY TO THE BACKSIDE OF THE FILTER.
 2. SERVICE AREAS NOT TO SCALE.

NOZZLE	CONNECTION	TYPE	SIZE	RATING
A1	SERVICE PORT	FLANGED	3.5" ASA	CL. #150 F.F. w/ Blind
A2	PRESSURE RELEASE	THREADED	1" NPT(2)	
K1	HIGH PRESSURE CONN.	THREADED	1/4" NPT(2)	
K2	LOW PRESSURE CONN.	THREADED	1/4" NPT(2)	
K3	HYDRAULIC CONN.	THREADED	1/4" NPT(2)	
N1	INLET	FLANGED	10" ASA	CLASS #150 F.F.S.O.
N2	OUTLET	FLANGED	10" ASA	CLASS #150 F.F.S.O.
N3	FLUSH OUTLET	THREADED	2" NPT	
N4	FLUSH OUTLET	FLANGED	3" ASA	CLASS #150 F.F.S.O.

TOLERANCES (UNLESS OTHERWISE SPECIFIED)	
FRAC. ±1/16	ANGLE ±1°
.X ±.1	
.XX ±.05	
.XXX ±.010	
MATERIAL: SST	
DRAWN BY: M. SERRANO	
DATE: 10/16/19	
SCALE: 1:18	SHEET: 1 OF 1



TITLE: CS-ABW10-P FILTER, CUT DRAWING

DRAWING NUMBER CS-ABW-10P-CUT-01	REV N/A
--	-------------------