

**FRONT VIEW**

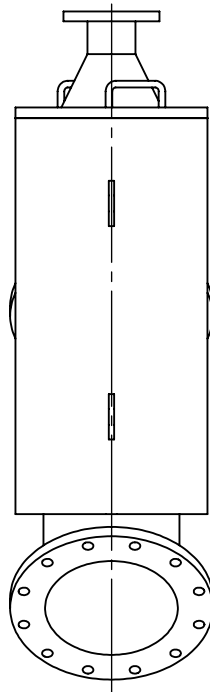

**BACK VIEW**

| REVISIONS |      |             |      |         |
|-----------|------|-------------|------|---------|
| REV.      | ZONE | DESCRIPTION | DATE | INITIAL |

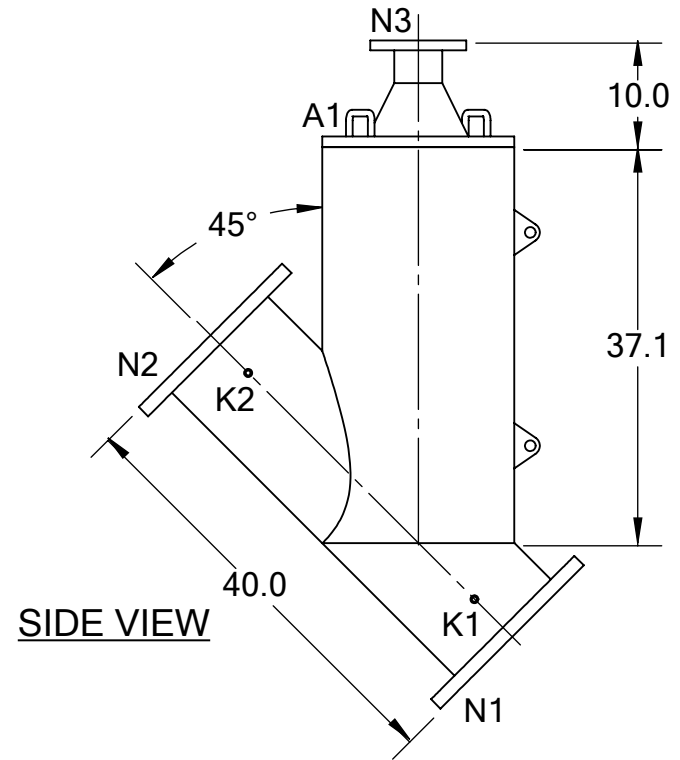

**SIDE VIEW**

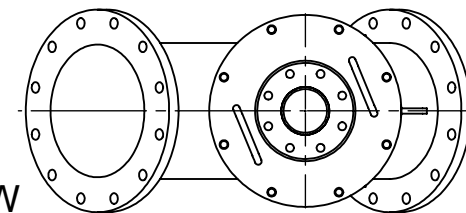

**TOP VIEW**

**TECHNICAL DATA**

|                    |   |
|--------------------|---|
| FLOW RATE          | MAX. 4,000 GPM (908 m <sup>3</sup> /hr) |
| SCREEN SIZE        | ___ MICRON                              |
| SCREEN AREA        | 9.5 SQ. FEET                            |
| DESIGN TEMPERATURE | 160 °F                                  |
| DESIGN PRESSURE    | 150 PSI                                 |
| EMPTY WEIGHT       | ~475 LBS.                               |
| FULL WEIGHT        | ~975 LBS.                               |

| NOZZLE | CONNECTION          | TYPE     | SIZE        | RATING              |
|--------|---------------------|----------|-------------|---------------------|
| A1     | SERVICE PORT        | FLANGED  | 18" ASA     |                     |
| K1     | HIGH PRESSURE CONN. | THREADED | 1/4" NPT(2) |                     |
| K2     | LOW PRESSURE CONN.  | THREADED | 1/4" NPT(2) |                     |
| N1     | INLET               | FLANGED  | 12" ASA     | CLASS #150 F.F.S.O. |
| N2     | OUTLET              | FLANGED  | 12" ASA     | CLASS #150 F.F.S.O. |
| N3     | FLUSH OUTLET        | FLANGED  | 4" ASA      | CLASS #150 F.F.S.O. |

| TOLERANCES<br>(UNLESS OTHERWISE SPECIFIED) |                      |
|--|----------------------|
| FRAC. ±1/16                                | ANGLE ±1°            |
| .X ±.1                                     |                      |
| .XX ±.05                                   |                      |
| .XXX ±.010                                 |                      |
| <b>MATERIAL:</b> SST                       |                      |
| <b>DRAWN BY:</b> M. SERRANO                |                      |
| <b>DATE:</b> 10/08/18                      |                      |
| <b>SCALE:</b> 1:18                         | <b>SHEET:</b> 1 OF 1 |



**TITLE:**  
CSF12-L FILTER WITH  
4" FLANGED FLUSH OUTLET,  
CUT DRAWING

|                       |            |
|-----------------------|------------|
| <b>DRAWING NUMBER</b> | <b>REV</b> |
| CSF-12L-CUT-01        | N/A        |